

# Reliability Factors for Ground Electronic Equipment

*Keith Henney, Editor in Chief*

*Irving Lopatin, Associate Editor*

*Elmer T. Zimmer, Associate Editor*

*Leonard K. Adler, Operations Manager*

McGraw-Hill Book Company  
Technical Writing Service

*Joseph J. Naresky, Project Engineer*

Rome Air Development Center

McGraw-Hill Book Company, Inc.  
New York Toronto London 1956

This book was prepared by the McGraw-Hill Book Company, Inc. for the U. S. Government under a contract with Rome Air Development Center, Griffiss Air Force Base, Rome, New York. The Government has granted to the Publisher the right to print and sell this book commercially. Certain portions of this book are reproduced with permission of the respective copyright owners. Any further reproduction of this material may not be made without the permission of the holders of such rights.

Publication of this document has been made possible through support and sponsorship extended by the General Engineering Laboratory of the Rome Air Development Center under the contract No. AF 30(602)-912.

# PREFACE

Every electronic engineer working on military equipment has, by now, heard that there is a reliability problem. The bald truth is that much of our elegant military electronic equipment simply does not stay in service long enough, the cost in dollars and in manpower of maintaining it in working condition is much too high, and the probability that it will not function properly at the wanted time and for the desired duration is greater than can be tolerated.

To be perfectly fair, however, to the designers of this equipment and to put the matter in its proper perspective, it is only proper to state that much of our modern household and industrial apparatus is not too reliable either. The reliability of the old-fashioned washboard, the dishpan, and the clothesline is simply phenomenal compared to that of their modern counterparts!

This book discusses the numerous reasons why military electronic equipment **does** not have the necessary reliability. Statistics pinpoint the most likely and most prevalent malfunctions and, finally, ways by which greater reliability in future equipment can be accomplished are pointed out.

That is the purpose of this book, the first on the general reliability problem. Although it is aimed primarily at the designer of ground equipment, the problems and most of their solutions are general and the techniques are applicable to industrial as well as military equipment designers.

No one is more aware than the editors who worked on this project that the book only scratches the surface of the reliability problem and that, as time goes on, much more will need to be said. It is a start, however.

The editor and his associates at McGraw-Hill, Irving Lopatin, Elmer T. Zimmer, and Leonard K. Adler and the publishers have a considerable feeling of pride in being able, through this volume, to make a contribution toward improving the functional reliability of our elegant military electronic equipment now requiring the efforts of so many of our best engineers.

Throughout the task of collecting the information and reducing it to book form the editors have had the guidance of Joseph J. Naresky of the General Engineering Laboratory of the Rome Air Development Center, USAF. This guidance and the support and sponsorship of the laboratory have been greatly appreciated.

*Keith Henney, Editor*

# CONTENTS

## Chapter 1 RELIABILITY CONCEPTS

The general problem today – History of past studies – Programs to combat the problem – Definitions – Degrees of reliability – Industrial experience

## Chapter 2 CAUSES OF UNRELIABILITY

General causes – Examples of poor circuit and mechanical design – Complexity – The maintenance problem – Universality – Component parts applications – Standardization

## Chapter 3 SYSTEMS ASPECTS

Systems considerations – Interchange of information necessary for successful designs – Failure prediction

## Chapter 4 MATHEMATICAL APPROACH TO RELIABILITY

The need for specific statistical descriptions of reliability – Quantitative definitions – Probability – The Exponential Law – “Series” and “Parallel” reliability

## Chapter 5 ELECTRICAL AND ELECTRONIC FACTORS

Considerations pertinent to military design – Circuit Selection – Marginal testing – Redundancy – Electrical hazards

## Chapter 6 MECHANICAL AND ENVIRONMENTAL FACTORS

Environmental conditions to which military equipment is subjected – High and low temperatures – Moisture – Biological growth – Dust – Shock and vibration – Mechanical design principles – Miniaturization – Encapsulation – Hermetic sealing

## Chapter 7 HUMAN ENGINEERING

Fitting the machine to the man – Human performance limits – Body measurements – Practical application data

## Chapter 8 COMPONENT PARTS

Results of recent failed component parts studies -- Limitations of parts  
-- Proper application -- Tubes -- Specifications -- Characteristics --  
Resistors -- Capacitors -- Connectors -- Transformers -- Relays -- Vibrators  
-- Synchros

## Chapter 9 INTERFERENCE

Interference reduction at the transmitter -- Shielding -- Bypassing and  
filtering -- Mutual interference -- Harmonic suppression -- Grounding --  
Interference reduction at the receiver -- Limiters -- Wave traps -- Phase  
cancellers -- Audio filters -- Jamming

## Chapter 10 AUTOMATIC PRODUCTION

Impact of modern techniques on manufacturing -- Philosophies of new auto-  
matic assembly methods -- Advantages and disadvantages of new methods --  
Special military considerations

## Chapter 11 EQUIPMENT PUBLICATIONS

The designer and the equipment manual -- Liaison between designer and  
writer -- Types of Air Force publications

## Chapter 12 MAINTENANCE

The maintenance problem -- Fault locating techniques -- Failure prediction  
-- Marginal testing -- Accessibility -- Built-in equipment

# CONTENTS

## chapter one

### **reliability concepts**

Background

Ad Hoc Group

Advisory Group on Electron Tubes

ARINC Study

Signal Corps-Cornell Study

Vitro Study

Bell Laboratories-Navy Study

RETMA, JETEC, AGREE

Components Symposia

Service Attacks

Definitions of Reliability

Degrees of Reliability

Realistic Reliability

Relation Between Complexity and Reliability

Industrial Electronic Experience

# chapter 1

## RELIABILITY CONCEPTS

The problem of achieving reliability in military electronic equipment is one that constantly faces the designing engineer. However, the intensity of the problem varies from time to time. At the present time the problem is severe, but the possibility is good that its severity will be lessened in the foreseeable future. The reason for this optimism is that unreliability is widely recognized by designers who are studying its causes and are taking steps to prevent the most prevalent from affecting future equipment.

There will always be some unreliability; it is an inherent quality of all complex mechanisms, including the human being. The immediate problem is to increase reliability to the best possible point commensurate with the cost in time, money, and manpower and with the task for which the equipment is designed. We are far from this point, because at the present time we must learn to live with the vagaries of our equipment; our engineers are too concerned with design and production and too unconcerned with the business of keeping the machinery functioning properly.

Reliability is affected by every decision the designing engineer makes, from the choice and use of circuits and component parts, the arrangement of parts, and the environment in which the equipment will be used, to the viewpoint, capabilities, and problems of the man who ultimately must make the equipment work under conditions that cannot possibly be foreseen during design. And, while the designer is not solely responsible for reliability, it is the easiest thing in the world to blame him when a piece of equipment has a poor reliability record.

### BACKGROUND

**History.** It is not necessary to go back very far in time to realize the distressing importance of the reliability problem, nor is it necessary to set down in any great detail the statistics of the situation. It is reported that in 1949 about 70 percent of Navy electronic equipment was not operating properly./1/

Another statistic indicates that, during World War II, up to 60 percent of airborne equipment shipped to the Far East was damaged on arrival. Furthermore, as much as 50 percent of the equipment and spares in storage became unserviceable before it was ever put into use. /2/ The Navy was supplying a million replacement parts a year to keep a total of 160,000 pieces of equipment in operation, and was forced to keep 9 tubes in the pipe line for every tube in operation. The Air Force was reporting that it was barely able to get 20 hours of trouble-free operation from the electronic gear on bombers.

The Ad Hoc Group found, by studying failure reports and replacement parts data, that radio equipment was in trouble 14 percent of the time, radar equipment 84 percent of the time, and sonar equipment 48 percent of the time. Replacement of tubes outnumbered replacement of other components by a ratio of 5 to 1. In a 12-month period, approximately 180,000 tubes were replaced in 4,000 pieces of equipment; components other than tubes needed approximately 37,000 replacements in 1,850 pieces of equipment. /3/

The economic value of electronic equipment in present-day military or civilian equipment gives a small indication of the importance of keeping the equipment functioning properly. Prior to World War I, the total capital investment for electronic equipment in all civil aircraft was about \$4,000; the military picture was not much different. Pre-World War II fighters carried about \$3,000, and bombers about \$5,000, in electronics. Today, the capital investment for electronic equipment on a DC-6 is roughly \$30,000, on high-performance military aircraft the figure is closer to \$300,000, and on jet bombers the cost may be as high as \$750,000. By 1953, aiming equipment for anti-aircraft guns was utilizing 500 tubes and 20,000 electronic parts. A mission of forty B-50 planes carries a total of 10,000 tubes. /4/

These above discussions show, first, the difficulty of getting material from one place to another

in usable condition, no matter how well designed the electronic circuits might be; second, that even in storage the equipment deteriorates; and third, that it is difficult to keep equipment in good operating condition once it is out of storage, has survived transport hazards, and is in its normal operation location.

The Problem. During the emergency of World War II it was not readily or quickly seen that the introduction of intricate electronic systems that extended human capabilities brought new problems of all sorts. It was not realized that mere development and use of revolutionary military equipment was not enough; something new was required. Complex as the equipment was, still greater complexity was necessary, so that the human operator could be completely relieved of everything that did not call upon his innate capabilities — his ability to reason, to take stock of a rapidly changing situation, and to take steps to correct the situation, if correction was needed. To do this, the equipment had to be failureproof and capable of being repaired quickly and, preferably, automatically.

"Complexity of operation (not the same as circuit complexity) brings in the human who uses the equipment. The electronic equipment used in the Air Force in World War II simply required of the user too many parallel actions. At a time of great emotional strain, being under attack, ... his ability to reason and rationalize was destroyed. The result was a great plague of gross errors ... which was difficult for the designer of the equipment to understand or explain. These errors were the result of the operator actually forgetting to perform some important calculation, or actually making an erroneous calculation, or failing to apply reason to a sudden turn of events." /5/

Radar not only increased the operator's capability, it also increased his task in other ways. Following the war, the job for designers was to make the machinery more automatic, to relieve the operator of every function that the equipment could perform, freeing human abilities so that they could be utilized where needed most.

All of this complication of equipment brought maintenance problems and, since it seems to be axiomatic that a complicated piece of machinery is more likely to get out of adjustment or to fail completely, the reliability problem became more severe very rapidly.

Utilizing the human factor to best advantage requires that the equipment work properly at the time it is needed — in other words, it must be reliable. Complex and beautiful instrumentation is the key to relieving the human being of unnecessary mental and physical work. The job however, is to achieve reliability in spite of complexity.

Attacks on the Problem. A broad attack on the the problem by industry and government began to take shape in 1950-1951, along with the realization that it was costing us more to maintain our military electronic equipment than to design and build it, that

missions which depended upon electronics failed too often because of failure of the very electronics that made the missions possible, that the whole success of our defense effort was bound up in the reliability problem, and that many men would not return from a mission unless the electronic equipment could be made to work with much greater certainty at the time it was needed.

The results of the several programs undertaken during that period are summarized here.

Ad Hoc Group. The so-called Ad Hoc Group on Reliability of Electronic Equipment in the Research and Development Board (RDB) was formed on 7 December 1950 by the committee on Electronics. The Group was to examine the entire electronic reliability situation and to recommend measures that would result in reliable equipment requiring a minimum of maintenance. The Ad Hoc Group operated until 12 March 1952, /6/ and prepared the groundwork for future attacks on the problem.

The Ad Hoc Group made certain recommendations:

1. Better factual data on performance of equipment and component failures should be obtained either through improved reporting by the regular operating and maintenance personnel or through specially organized programs involving contractor participation.
2. Development activities on better components should be stimulated.
3. The Services should establish quantitative requirements on the performance reliability of equipment and components.
4. A program of widespread education of Service and industry personnel should be instituted to spread the philosophy of reliability in all phases of evolution of new equipment.
5. The Services should obtain a thorough evaluation of newly designed equipment by both laboratory and field tests before authorizing full-scale production.
6. The Services should assure that contractors designing equipment work closely with their subcontractors supplying components to ensure compatibility and avoid misapplication.

Advisory Group on Electron Tubes. During the first year of World War II, the Bureau of Ships of the Navy Department and the MIT Radiation Laboratory of Division 14 of the Office of Scientific Research and Development (OSRD) realized that problems were arising because of lack of coordination in the development of new tubes for war use. The Bureau of Ships, members of the OSRD Transition Office, and the Radiation Laboratory jointly developed



a proposal for an agency to coordinate the development of vacuum tubes. This proposal was reviewed by the Joint New Weapons and Equipment Committee of the Joint Chiefs of Staff, and the Chairman of the National Defense Research Committee (NDRC) was requested to establish the Committee. The first meeting of the Vacuum Tube Development Committee (VTDC), as it was first called, was held in June of 1943. A full-time Secretariat was established in December 1943 under a Joint-Services contract at Columbia University. Committees were organized to interchange information among the development agencies and to formulate OSRD and Service policy for the direction of the development of tubes.

After proving its value, the VTDC was reorganized on 24 October 1946 by the establishment of the Panel on Electron Tubes (PET) and in May of 1949, the work of the Secretariat was taken over by the Research Department of New York University.

During 1953, the Department of Defense underwent reorganization; one of the decisions made was to dissolve the Research and Development Board (RDB), reexamine its functions, and transfer those deemed useful to the Office of the Assistant Secretary of Defense (Research and Development). PET was preserved with virtually no change in objectives, functions, structure, or mode of operation; the name, however, was changed to Advisory Group on Electron Tubes, (AGET) to conform to the new scheme of organization.

In the field of reliability, AGET has built up an extensive program. This program includes three major efforts:

1. Coordination of field surveillance of equipments in actual military use at various Army, Navy, and Air Force installations, including the collection and analysis of failed tubes to determine their nature and cause of failure. In an average year, 30,000 tubes failing in the field may come under scrutiny.
2. Administration of an Applications Engineering Program. Approximately 170 tube-application engineers of various tube manufacturers are available, through AGET, as unpaid consultants on tube applications for increased reliability to electronic equipment contractors. Consultations are arranged by the AGET Secretariat at the request of the contractor, and are held under conditions that preclude manufacturer bias. Contractors request consultations through their Service Project Engineers.
3. Publication and dissemination of information on the proper application of tubes, including the preparation of Tube Application Notes, the sponsoring of symposia, and functioning as a center of information on the subject.

ARINC Study. On 4 April 1951 the Bureau of Ships, Department of the Navy, and Aeronautical Radio Inc. (ARINC) entered into a contract to investigate electron tube reliability at Army, Navy, and Air Force bases (NObsr-52372). The procedure was to collect tubes removed from sockets at eight bases and ship them to the Washington laboratory of ARINC, where they were analyzed to determine the faults. General Report No. 1 of 4 January 1954 gives the results of the study of 45,013 tubes collected during the period from 18 September 1951 through 31 March 1953, from a socket population of 489,049 at the eight bases. /7/ This work continues by a renewal of the Navy contract, dated 31 March 1954.

ARINC determines the mechanical and electrical reasons the tubes were removed from equipment. Certain tubes are shipped to other laboratories for the determination of the basic reasons they were rejected from equipment. Many tubes are returned to manufacturers for examination and information.

Signal Corps-Cornell University Program. The purpose of the Signal Corps Tube Analysis Program at Cornell University is to determine the factors of unreliability in electron tubes by analyzing tubes that have been rejected from military equipment. In addition to routine tests and detailed examinations, the analysis includes a consideration of the tube application. The program began in July 1951.

The sources of tubes for the Cornell program are ARINC and manufacturers of military equipment.

The tubes collected by ARINC may be classified as either uncontrolled or controlled. Uncontrolled tubes are tubes that have been used an unknown length of time and for which no initial information, such as values of tube parameters, is available. Controlled tubes are tubes for which initial information, as well as hours of service, is available; that is, the parameters of the tube were determined before the tube was inserted in a socket. For either class of tube, ARINC prepares a punched card containing all known information about the tube, including the reason for rejection, and sends the tubes and cards to Cornell.

The tubes supplied by manufacturers of military equipment are the result of the manufacturer's participation in a "line-reject" program. Such a program is established when the rejection rate of tubes in the equipment during construction and test exceeds a specified minimum. In these programs, the manufacturer collects and ships the tubes to Cornell, along with information about the tubes and their application.

At Cornell, all tubes first are given a visual examination to eliminate untestable tubes. The remainder are subjected to a series of tests based on MIL specifications, so that the exact fault, if any, may be determined. (Many tubes, approximately 30 percent of those tested to date, have no defect according to MIL specifications.) If the results of the

testing process indicate that a microscopic examination, chemical analysis, X-ray analysis, or special tests are required, the tubes involved are routed through the testing sections established for these purposes. After all tests and examinations have been completed, a code number corresponding to the defect status of the tube is assigned, and the pertinent test results are inserted into the punched card assigned to the tube. One copy of the completed punched card is retained at Cornell and one is sent to ARINC.

Up to 24 August 1954, approximately 100,000 tubes, in 461 different types, had been received and tested. Although the number of tubes in some types is becoming significant, a straight statistical analysis by tube type has doubtful significance because of the many tube manufacturers and large number of different applications represented. In many instances, however, sources of trouble have been isolated by the examination of relatively few tubes of a given type.

No broad conclusions have been drawn as yet concerning the reliability of electron tubes on the basis of the results of this program. Considering the total of all tubes received, the predominant defect percentages occur in the "Outside Electrical Limits" category and the "No Defect Found" category. That the Outside Electrical Limits category has a high percentage is to be expected, and suggests that increased reliability is to be attained by strengthening those factors that contribute to the length of time that the parameters of a given tube will stay within design limits. The fact that the percentage in the No Defect Found category is so high suggests that equipment design and maintenance procedures must be so modified that the full range of operating limits for a tube is realized and the tube is not permanently removed from its socket until these operating limits are reached.

Although the defect percentages in other categories are small compared to the two mentioned, every effort is being made to determine how they may be reduced to result in an electron tube of the utmost reliability.

Vitro Study. One of the first attempts to get some statistical insight into the component failure problem was the letting of a contract by the Navy to the Vitro Corporation to institute an Electronic Equipment Reliability Program. Nearly 30,000 reports of individual component part failures collected by the Bureau of Ships were studied. Tubes were not included. The reports covered the term 1 November 1949 to 1 December 1950 and represented only a small fraction (perhaps 2 to 3 percent) of the total failures occurring during that time, as the reports were prepared on a voluntary basis by the men making the repairs. The study covered an equipment population of slightly over 140,000, with a parts population of about 14 million having 23,503 stock numbers. During the period there was a replacement parts issue of 1,957,822 units (excluding a half million fuses) having 6,233 stock numbers.

The study showed that the nine most commonly used parts types were somewhat more reliable

than parts used less often, a fact borne out by other experience; that is, parts in wide production and use were more reliable than parts in small production and use.

Considerable data will be found in Report No. 25, 1 November 1951, Parts Failure Analysis, and some of this data will be found in the chapter on components in this book.

Even at the early date of this study, it was found that parts failed because they were forced to operate near their maximum rated power or peak voltage, and in applications particularly sensitive to parts stability. It was already apparent that a more rigorous standardization program would pay off, that better parts were required, and that an improvement in parts application would be eminently worthwhile.

Bell Laboratories Navy Project. After the Vitro study indicated that component parts, as well as tubes, were causing a considerable amount of trouble, a contract between Bureau of Ships and the Bell Telephone Laboratories (NObsr 52480) was entered into for the purpose of studying components, other than tubes, that were removed from working equipment. Between 1 July 1951 and 1953, when the study ended, 1,763 component parts had been examined in the laboratories. Of these, 666 were resistors, 457 were capacitors, and 155 were transformers. The remainder included relays, coils, crystals, and so on. The causes of failure were about equally divided among "operational conditions," manufacturing defects, and design deficiencies, with 15 percent allotted to failures caused by undetermined causes. A detailed breakdown of these failures will be found in the chapter on components.

RETMA. With the realization that the reliability problem affected industry, as well as Government, the Engineering Department of the Radio, Electronics, and Television Manufacturers Association (RETMA) established the Committee on Electronic Applications (reliability) and the first meeting was held on 12 March 1953 under the chairmanship of L. M. Clement. The objectives of this committee are:

1. Establish procedure for collecting and using reliability information available to the various agencies of the Government and private industries.
2. Formulate plans to educate the design and project engineers in industry and Government so that reliability can be built into the equipment.
3. Cooperate fully with Government agencies and industry in the implementation of plans and programs for the improvement of reliability of electronic equipment.

The membership of this committee is made up of representatives from tube, component, computer, and military equipment manufacturers and research laboratories, plus observers from the military departments and agencies of the Government. The

Committee issues bulletins /8/ through the engineering department of RETMA.

JETEC. The Joint Electron Tube Engineering Council (JETEC) was organized to develop standard materials and to conduct engineering activities for organizations in the field of tubes and allied devices. It develops proposals for adoption as standards by sponsoring organizations, and issues technical data. It functions as an autonomous body in contacting outside groups in carrying out its chosen responsibilities. It is sponsored by RETMA and the National Electrical Manufacturers Association (NEMA).

AGREE. As a result of the recommendation of the Ad Hoc Group that a permanent committee be established, the Department of Defense issued a directive on 21 August 1952 establishing the Advisory Group on Reliability of Electronic Equipment (AGREE) as an agency of the Committee on Electronics of RDB. AGREE was to:

1. Examine all phases of electronic equipment reliability, beginning with the idea and going through research and development and the sequential steps through operation and maintenance.
2. Stimulate interest in any program that will result in more reliable equipment.
3. Make recommendations to appropriate agencies, government and civilian, in regard to measures that will result in more reliable equipment, better education on reliability, and implementation of reliability programs.

Numerous meetings of AGREE have been held at which representatives of both Government and industry have contributed in many ways.

On 31 March 1954 AGREE was transferred from the Office, Assistant Secretary of Defense (R&D) to the Office, Assistant Secretary of Defense (Applications Engineering). Mr. L. M. Clement is chairman of AGREE.

Components Symposia. Three symposia of three days each have been held under the sponsorship of AIEE and IRE. Numerous papers and talks on the general subject of reliable components, with particular emphasis on new developments, were presented at these symposia. Printed proceedings are available. /9/

Service Attacks. Of course the Services have not been idle and have made major improvements in their respective reliability records. A clear understanding of the causes of trouble, after the equipment is designed, built, installed, and operating, has enabled definite programs to be established.

The Overall Program. Obviously the first job was to determine the causes of failures of electronic equipment. And since failure of component

parts was the visible cause of equipment failures, the first step was to determine which components failed most often. The next step was to find out why they failed. The first step, for many reasons, is easier.

Components, including tubes, cause most of the failures. Therefore, a rigorous program was promulgated to develop components that would stand up better in military life. At the same time some effort was made to learn to use existing components in circuits and equipment less sensitive to environment. In other words, to design equipment that would tolerate wider changes in component characteristics as well as environmental conditions.

To attack the problem by producing and using better components is the logical but not the easiest approach. The ultimate in reliability will be attained only when certain compromises are made — among them, the compromise between an elegant function to be performed and the inevitable complexity required; the compromise between elaborate equipment that requires expert usage and maintenance, and the lack of interest in the equipment and lack of technical competence by field personnel.

The cost of reliability in a slowing up of technical "progress" remains to be assessed, but it is real.

Much has already been learned. It is realized that the reliability of any particular piece of equipment has two broad aspects. The first is the inherent reliability designed and built into the equipment. The second is the ease of maintenance — also built-in. The first aspect involves the circuit design, the proper choice and usage of component parts, proper care to minimize failures due to high temperatures, low pressures, vibration, humidity, and manhandling. The object of all these efforts is to reduce the number of failures.

The maintenance aspect involves the techniques employed to make location and repair of faults easy and quick, so that the equipment gets back on the air in a minimum of time after a failure.

"Means for achieving inherent reliability start with the system specifications and include the development of more reliable components, the control of component environment, the pre-testing of units, and standardization of assemblies.

"Methods for simplifying the maintenance procedure concern the design of fault-locating devices, the use of failure anticipation, stand-by units, and obvious, easily identified layouts."/10/

Wherever routine maintenance can forestall emergency, maintenance manpower is conserved, time is saved, "down time" is reduced. All these are essential goals. The designing engineer can do much to achieve them.

Whatever attacks are made, whatever programs are set up, it must be remembered that no

magic formulas exist through which equipment can be endowed with the desired reliability. Only hard, unremitting work at every level of responsibility, at every stage from concept to development, to production, to use, and to maintenance will produce the desired results. It is a job in which every man can have a share.

Reliability cannot be legislated into equipment, it must be build-in. In this endeavor small things will count. The large things are apparent; they stand out and are fixed early in the design-production-use time schedule. But the small things that count are often hidden.

"Human engineering recommendations, taken as individual items, may often seem trivial. But multiply the savings of a few seconds or minutes by many operations and the potential reduction of red time in the entire system may become substantial enough to spell success or failure for the system. Small gains in reliability, if sufficiently multiplied, finally tighten the defense mesh to a degree of strategic importance. These gains will be especially important in actual warfare conditions when time and reliability are indeed critical under conditions of stress and huge disturbance of men and material."<sup>11/</sup>

Reliability is the responsibility of everyone. If it is arbitrarily approached from the top, without adequate technical background, the engineer-designer must work under a tremendous handicap. He is lusted at the start. But if he is aided in the reliability-improvement program by everyone involved with the equipment, from those preparing the original military requirements and to those who finally maintain and use the equipment under operational conditions, then the designer will be allied with a complete team.

## DEFINITIONS OF RELIABILITY

Many man-hours have gone into attempts to arrive at a universally acceptable definition of reliability and its reverse, unreliability. The definitions depend upon the concepts involved. Each has its use; and of course attempts are made to express these concepts in language that is amenable to quantitative statements, that is, in mathematical symbols.

From one point of view the important concept is the average length of time between failures for a specific piece of equipment. From another point of view the important statistic is the total number of failures encountered in a given number of specific equipments per given length of time. And still another viewpoint is interested in the number of hours of maintenance required to ensure one hour of satisfactory operation. The amount of time in percent that the equipment is in service (the in-commission rate) and the mission-success rate are other aspects.

And to these quantitative aspects may be added the qualitative aspect — even if the equipment does not fail, how well is it working how much of the time?

Giving numbers to the several reliability criteria requires life tests of more than one piece of specific equipment, the amassing of considerable data, and the proper assessment of the data once it has been collected. It is not an easy matter.

Giving reliability figures to any piece of equipment prior to life test calls for much more quantitative data than now exist on the components and how they stand up under actual practical environmental conditions. But the statistical methods are available, and a start has been made on putting them to use.

Greater detail concerning the several definitions of reliability noted above is to be found in the following paragraphs. In this book reliability will be considered as the ability of equipment to perform its intended job at the intended time. The mathematical bases by which definite indices may be applied to equipments and components will be found in Chapter 5.

Average Time Between Failures. The average life  $\theta$  may be defined as

$$\theta = Mt/f$$

where

$\theta$  is the mean life

$M$  is the number of equipments under test

$t$  is the time or duration of the test

$f$  is the number of failures during the test

This rating is convenient for use in determining if the reliability of the equipment is likely to be adequate for missions of specific lengths. Ryerson<sup>12/</sup> points out that this figure should not be confused with the mean life of failed components. In the latter case the component is junked; whereas the rating above, as applied to equipment, means that the equipment is repaired and the test continues.

Failure Rate. This measure of reliability is simply the total number of failures occurring in a given number of identical equipments per unit of time, usually one year. Much data have been, and are being, collected that will give significant information of this type on both equipment and component parts of equipment. In fact, much more data are available than have been summarized or analyzed, and it is quite likely that the rate of collection of such information is greater than the present ability to digest it. The published reports of the Vitro<sup>13/</sup> and Rand<sup>14/</sup> studies provide useful data of this kind to which more contemporary data may be compared. Once the failure rates for specific types and models of equipment are available, new equipment of the same type can be rated as to its relative reliability compared to the figures available on other similar equipment. Norms will be available for engineers and specification writers to shoot at and by which the products of designers and manufacturers can be rated.

Maintenance Rate. "This figure gives the number of maintenance man-hours required to support each hour of operation. It reflects the frequency of failures of the system, the amount of time required to locate and replace the faulty part, and, to some

extent, the overall efficiency of the maintenance organization. This method of measurement is ... valuable to operating agencies since, under a given set of operating conditions, it provides an index ... in estimating maintenance manpower requirements." /12/

In-Commission Rate. "This is the percentage of the total operational time (24 hours a day, 7 days a week) during which the equipment is entirely ready for operation or is in operation. It is directly related to the maintenance rate in that the more time spent in maintenance the less time the system is entirely ready for operation. This rating provides a basis for equipment logistics." /12/

Mission Success Rate. This is "defined as that percentage of the total missions uninterrupted by failure of the equipment. This figure of merit is more closely dependent upon the reliability of the parts included in the system and on the design of the system than are the maintenance rate or the in-communication rate. This measure of reliability is valuable ... to an agency with a regular schedule of missions. A mission success rate obtained by one agency is not typical of the equipment in general and will not necessarily apply for use by other agencies with different operating schedules." /12/

## DEGREES OF RELIABILITY

Much as everyone wishes for some absolute index by which an operator could be sure that a given piece of equipment would function correctly in a given situation for a given time, it is realized that this is not attainable. All that can be done is to affix some probability that the equipment will not fail, and to make the chance of failure as remote as possible, all other things considered.

Catastrophic Failures. Most of present interest is in complete failures, in which the equipment won't work at all. It is "off the air." The cause may be something as simple as a blown fuse, in which case the remedy is simple and quick. Or the cause may be a burnt-out resistor buried in the heart of the machine, where it is not only difficult to locate but difficult to replace. Under these circumstances the equipment is "down" for a considerable time, or the mission aborts.

It is now recognized that tube failures are most likely to occur during their early history, say the first 50 or 100 hours. Like human beings, whose mortality is greatest during their childhood, if tubes get over this critical period, they are likely to have a normal life expectancy. To avoid these "quickie" troubles it is becoming customary to "burn in" tubes or to age them before they are accepted or are permitted to go into the equipment. After this period, failures seem to follow an exponential pattern; in a given time a given percentage of those still in service must be replaced.

Old-Age Troubles. Less than catastrophic in degree of failure are situations in which the equipment works, but not very well. A transmitter may get off frequency and the operator at the receiv-

ing end of the circuit can't follow it; a radar may have its range severely restricted; an automatic typewriter circuit may produce hash instead of intelligence. But the device or the system still works, to a degree.

Such degrees of unreliability result from a degradation of the individual efficiencies of parts of the system or parts of a piece of equipment. Tubes lose emission, and amplifier gain goes down. Resistors or other components change in value sufficiently so that the circuits of which they are important parts no longer produce the required effects. The longer the equipment or system operates, after the initial high-failure period, the greater chance it will wear out at any given moment; so much of its total history has already taken place.

Recognizing that the component parts of a device have definite lives has caused maintenance philosophies to be built up which dictate that all the tubes of a given equipment should be replaced at some definite term of usage, say 1,000 hours. But recently, much experience indicates that if a tube has not failed to date, it is better to leave it in its socket doing its job than to replace it with a new tube, whose chance of failure is totally unknown. The several projects for studying tubes removed from military equipment have indicated that about one third are still within their required electrical limits, thus bolstering the feeling that wholesale removal of tubes at the end of a certain period of use is not a good idea.

The theory that the longer any device or system lives, the greater its chance for failing is in some disagreement with the purely exponential law that seems to govern complex equipment, where the causes of failure are many, and seemingly fortuitous. If a tube fails because of cathode wearout, and for no other reason, it is a fact that the longer the tube burns, the less time it will have to burn — its store of emissive material has been dissipated. On the other hand, if it fails from any one of numerous reasons, it is likely to follow the exponential law.

"A device is said to obey an exponential failure law if the probability  $P(t) dt$  of its failing between the times  $t$  and  $t + dt$  is

$$P(t) = \frac{1}{\theta} e^{-t/\theta} dt$$

where  $\theta$  is the mean life of the device. The survival probability is

$$P_S(t) = e^{-t/\theta}$$

and a device obeying such a law has a probability of failure which is independent of past history. It is ... independent of the age of the device." /15/

The fact that most emphasis, at the present time, is placed upon catastrophic failures does not mean that lesser degrees of unreliability are not serious. It means simply that they are hidden, they do not get the headlines. In a great many cases the equipment is already on the road to a catastrophe; something is running down; its blood pressure is weakening but its heart has not yet stopped beating.

When that event finally occurs, a catastrophe results and another failure is chalked up against the equipment. The slow degradation in performance caused by the effects of old age may be hidden by automatic volume control, automatic frequency control, excess gain, or other technical dodges, but it is still present; it is nature's hidden weapon.

"On a fleet basis, the number of equipments suffering from low performance greatly exceeds those that are inoperative due to component failure. It has been estimated that as much as 60 percent of the troubles experienced can be attributed to de-tuning and loss of adjustment and calibration."/16/

Realistic Reliability. We must not be unreasonable in approaching this problem. We must determine, somewhere along the line, how much reliability the equipment must have, how much we are willing to pay for it, and the relative responsibilities of the designing engineer and the echelons which control the abilities and pride of the men who operate and maintain the equipment. It is unrealistic to ask the engineer to make equipment that will do its job no matter how much manhandling is later involved; the engineer cannot solve all the problems, and the human equation cannot be solved by machinery.

Electronics is still a new art, it is changing rapidly, and this "progress" is likely to continue. Railroading, on the other hand, has reached a rather stable condition from the design, operation, and maintenance standpoint. And yet trains get into trouble; railroading is not 100 percent reliable even today.

Statistical Reliability. Purely from the statistical standpoint, the relation between complexity and failure is clear — the more complex, the greater the chance of trouble. These relations are shown in Figure 1-1, where the overall reliability of a system is plotted for various degrees of complexity and for various degrees of reliability of the individual components making up the system./17/ If, for example, a piece of equipment has 400 components, and if an overall reliability of 80 percent is required, on an average "not more than one unit out of 1,800 units of each component type" dare fail.

Looking at it in another way, Lusser points out that if an equipment has 100 parts, each with a reliability of 99 percent — which means that one out of each 100 parts will fail, on the average — then the equipment will have a reliability of only 36.5 percent.

The Real Relation Between Complexity and Reliability. In all the excitement about how complex modern military equipment is becoming, it must be clear that complexity, by itself, is no necessary deterrent to reliability. Those who demand simpler equipment are whistling in the dark to keep up their courage. What is needed is not simplicity, but reliability.

A three-stage amplifier with barely sufficient gain to do the required job is simpler than a four-stage amplifier with extra gain that can be devoted to heavy negative feedback — but the four-stage unit

will be more reliable. Its tubes and components can be operated more conservatively, and its heavy negative feedback makes it much more immune to changes in tube or component characteristics.

Adding marginal checking circuitry to any system makes the system more complex, but who will deny that the equipment reliability will be improved when the ratio of down time to operating time is the criterion? Large-scale digital computers, which achieve an amazingly high degree of reliability for their degree of complexity, incorporate very complex error-correcting codes, marginal checking circuits, and sometimes duplicate, or even triplicate, computation circuits to gain their reliability.

Experience and design practices in large-scale computers may be a rich source of information for the reliability engineer.

Relative Reliability. Obviously there is no absolute reliability, either in degree or in time. That is, no equipment will work 100 percent correctly 100 percent of the time. Even the simplest device, or the most elegantly engineered instrument, with all factors of safety taken into account, will get old — it will wear out, and its performance will be degraded.

Proper design, proper selection and use of components, proper maintenance, and proper field care will produce electronic equipment of any degree of reliability. But is unrealistic to expect the utmost in reliability and the utmost in beautiful technical performance in the same small, light, unventilated package, just as it is unrealistic to expect equipment to be infinitely resistant to vibration and shock and at the same time to weigh practically nothing.

The difference in point of view on the reliability problem may be illustrated by the two curves in Figure 1-2. They give, respectively, the percent of original tubes still in use in a piece of equipment after a certain number of hours of use, and the percent of the original quota that has been replaced. From one point of view (usually that of the designer and producer) one may be happy that so many tubes of the original complement are still functioning; from the other point of view (that of the user) one may view with alarm that so many tubes have failed.

How much reliability do we have a right to expect? An automobile that travels an average of 40 mph for 1,000 hours has gone 40,000 miles and is ready for a major overhaul, not to mention occasional and unexpected periods of repair during this time. If the car goes four times as far, it is ready for the junk heap. And yet 1,000 hours represents less than two months' continuous service. A modern electric refrigerator is guaranteed for 5 years or 40,000 hours of service, whichever occurs first. It furnishes this service with little or no maintenance. But it does not run continuously, it operates under much better conditions than military equipment; it is vastly simpler than most electronic apparatus.

The Basic Problems. No one argues that military equipment should not be as reliable as

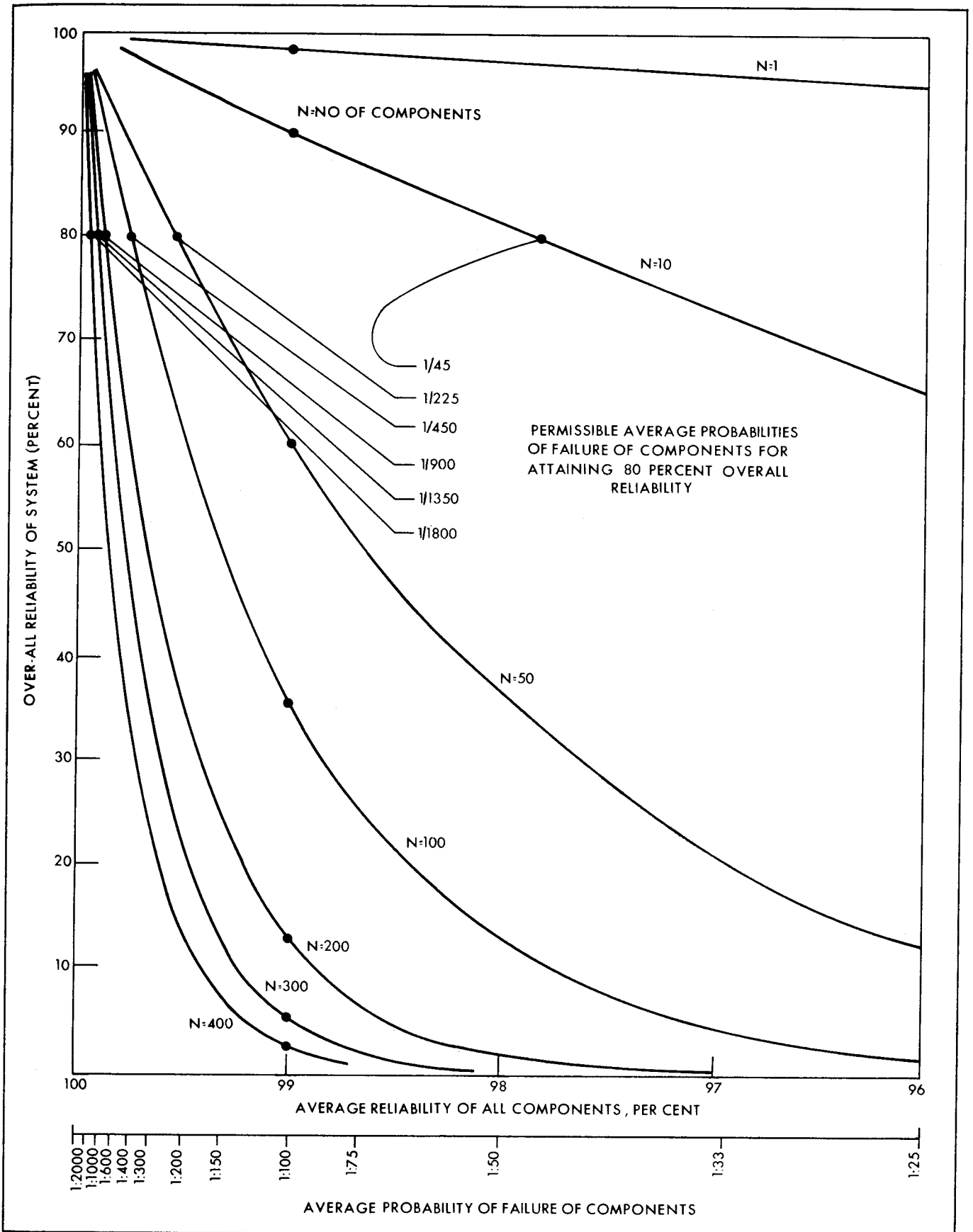

Figure 1-1. Overall reliability as a function of complexity, number of adverse conditions, and average reliability of components.

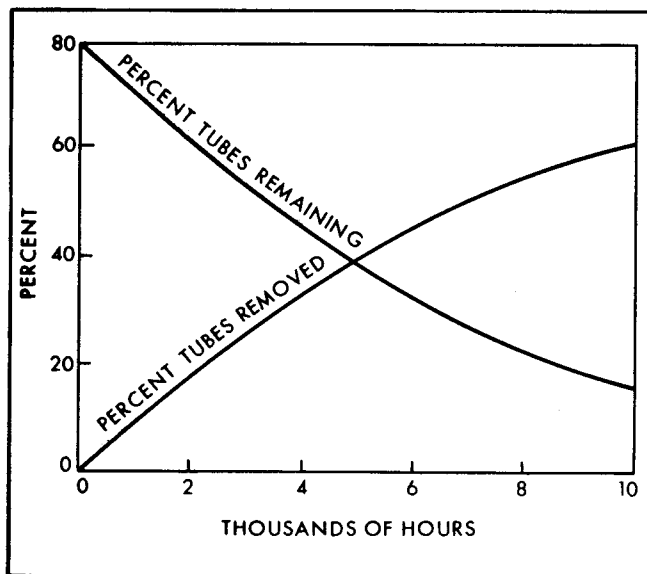

Figure 1-2. Percentage of 171 tubes (6AS6) removed or remaining in service as a function of time in a computer. ("Computer Reliability," *Radio and TV News*, E. S. Rich and R. R. Rathbone, February 1953.)

possible; yet everything works against this ideal. The electronic equipment is complex; its production is neither small enough for the units to be made by hand by skilled craftsmen nor large enough to enjoy the benefits of long runs on the production line. We are very cost conscious, afraid of taxes. Instead of buying the best possible equipment, we buy the product of the manufacturer who will supply it at the lowest price. This may be economically sound so far as first cost is concerned but may be definitely detrimental from the viewpoint of first cost plus maintenance. A cheap instrument may only be a ticket to expensive maintenance. Reliability costs money.

Design engineers seldom have a chance to see the results of their bread board and drafting board labors in action in the field. From this aspect designers are often working in the dark. And the maintenance crews at present have little opportunity or incentive to master their jobs — there is no career in it.

**Industrial Electronic Experience.** There are many reasons the designer of military electronic equipment has much more to learn from the designer of industrial electronic apparatus than from the designer of home radios and television sets. The utmost in reliability is required by industry before it agrees to permit electronic equipment in its factories. Interruptions to service are costly; in fact the economic motive is the reason for installing electronic apparatus in a manufacturing plant. A production line that is shut down because something went haywire in its controlling electronics represents the difference between profit and loss. One such catastrophe is enough to damn electronics in that plant for a long time. If the job can be accomplished in almost any other way, it will be so done.

Industry cannot afford to employ unreliable equipment and has learned that it is not necessary. Good design and manufacture will enable the equipment to stand up under terrific abuse after it gets into the factory in which it is employed.

"Since sufficient improvement in component reliability has not yet occurred which automatically would permit a major improvement in equipment reliability, engineers must use such expedients as their experience shows to be helpful. These are the simple, common-sense, but totally unromantic methods of established good engineering practice in design, installation, maintenance and service. What must concern engineers for the present, therefore, is the continued emphasis on these practices and the further extension of their use. While all of the above mentioned are important, at the present time most emphasis must be placed on good design; first of the components and second of the equipment.

"In heavy industry, experience has shown that the failures are most frequently due to faults of a mechanical nature. Thus, mechanical design is likely to be every bit as important as the purely electronic aspects of the device, and designs which would be mechanically acceptable in the (home) radio field cannot be tolerated in heavy industry.

"It is not of so much importance that a unique and efficient electronic circuit be provided as it is that the equipment be able to stand the everyday treatment which is normal in industry. The use of such equipment dictates many aspects of the design insofar as reliability is concerned. Choice of materials to be used and knowledge of materials of fabrication assume new importance. Equipment which must be located beneath the pass line in a hot strip steel mill will be subjected to heat and a bath of water, steam and scale and in many installations the water will, without doubt, be contaminated with acids. In such a situation a stainless steel tank would serve admirably as the cabinet, but if this tank must also hold light insulating oils, it is by no means certain that stainless steel should be used. The question of how to weld such a structure to retain the oil would now assume a far greater importance than whether to use regeneration in some amplifier within such a cabinet."/18/

Thus, in the industrial field, as in the military field, engineering problems are much different from those that plague the home radio field. For military equipment, however, home radio components must be employed for the simple reason that vast quantities of these parts are likely to be needed and in a relatively short time. The military electronics designer operates under a dual handicap; he must build equipment with the stability and reliability of industrial apparatus, but he does not have the opportunity to pick and choose, and use highly selected and, perhaps, handmade components. The methods employed by the industrial engineer, however, form good background and often provide specific techniques of value to the military designer.

**Reliability — A Two-Stage Problem.** The first job, of course, is to reduce the catastrophic



failures and the unpredictable failures to the absolute minimum. When that point has been reached, the job is to learn to live with the equipment and to keep it in topnotch condition with the least expenditure of

manpower and time. The prime requisites are for better information, for education, and for more knowledge from the top down. All the problems will be easier to solve if everyone has a better idea of the other fellow's troubles.

## REFERENCES

1. U. S. Naval Electronics Digest, vol. 8, February 1949.
2. Dummer, G. W. A., "Engineering Design of RAF Radar Equipments," Telecommunications Research Establishment, (TRE) Technical Note No. 122, 26 June 1951.
3. Given, F. J., Reliability in Electronic Equipment, Guided Missile Committee of Aircraft Industries Associated, White Sands Proving Ground, 20 April 1954.
4. "Economics of Aircraft Operation," Stanford Research Institute, Research for Industry, July 1954.
5. Nordlund, R. J., "Complexity of Military Electronics," Skyways, February 1954; also in Engineers Digest (RCA), March-April 1954.
6. Progress Report on Reliability of Electronic Equipment, vol. 1 and 2, Research and Development Board, Dept. of Defense, EL/217, February 1952.
7. Investigation of Electron Tube Reliability in Military Applications, General Report No. 1, April 1954, summarized in Electronics, April 1954 and Aviation Week, April 5 and April 19, 1954.
8. Electronic Applications Reliability Review, RTMA, 500 Fifth Ave., New York, N. Y.
9. Proceedings of Symposium, Progress in Quality Components, Washington, D. C., May 5, 6, and 7, 1952, RTMA, 777-14 St. N.W., Washington 5, D. C.  
Proceedings, Electronic Components Symposium, April 29 and 30 and May 1, 1953, Suite 1011, 621 South Hope St., Los Angeles, Calif.  
Proceedings, Electronic Components Symposium, Washington, D. C., May 4, 5, and 6, 1954, RTMA, 777-14 St. N.W., Washington 5, D. C.
10. Maintenance Minimization in Large Electronic Systems, Stanford Research Institute, Final Report (Confidential), 15 January 1952.
11. Survey of Human Engineering Needs in Maintenance of Ground Electronic Equipment, American Institute of Research, February 1954.
12. Ryerson, C. M., "The Measure of Reliability," Engineers Digest (RCA), 1954.
13. Parts Failure Analysis, Vitro Corporation of America, Report No. 25, 1 November 1951.
14. Carhart, R. R., "Survey of Current Status of the Electronic Reliability Problem," Report No. RM-1131, The Rand Corp., Santa Monica, Calif., August 14, 1953.
15. Drenick, R., and S. W. Spaulding, "Vital Factors in Designing for Reliability," part 3, Engineers Digest (RCA), January-February 1954.
16. Tall, M. M., "Component Failure Problems in Navy Electronic Equipment," Proceedings of Symposium, Progress in Quality Components, Washington, D. C., May 5, 6, and 7, 1952.
17. Lusser, R., "The Statistical Aspects of Reliability," Electronic Applications Reliability Review, RETMA, No. 2, 1953.
18. Cook, E. D., "Reliability in Industrial Electronic Equipment," Communication and Electronics, AIEE, p. 351, September 1953.

# CONTENTS

## chapter two

### **causes of unreliability**

State of the Art

Electrical and Electronic Design

Mechanical Design

Complexity

Universality

Systems vs. Component Buying

Lowest Bidder Practices

Specifications

Production Problems

Operation and Maintenance Personnel

# CAUSES OF UNRELIABILITY

There are many reasons why complex electronic equipment fails; and they are not hard to find.

General Causes. The reasons advanced for a lack of reliability of military electronic equipment fall into the following classes, each discussed in some detail in the following pages:

1. Unrealistic demands from the field or from top echelons for equipment beyond the state of the art - often mere "dream" ideas.
2. Poor engineering practices that result in improper circuit design or component applications, or inadequate mechanical devices.
3. Complexity of equipment that results in overworked circuitry and personnel. Complexity is often caused by under-engineering. It takes longer to design simple equipments than complex ones.
4. "Overuniversality," so often suggested as a cure-all for reliability and logistics problems.
5. Lack of systems thinking in procurement operations.
6. Procurement practices that exclude all but the lowest bidder.
7. Unrealistic specifications that do not require reliability or specific performance levels.
8. Production methods that are influenced by "low bidder" tactics and "crash programs."
9. Inadequately trained personnel, incapable of operating or maintaining modern electronic equipment. Short terms of duty,

rotation, and lack of incentive are the major causes of this condition.

## DESIGN CONSIDERATIONS

State of the Art. Electronic design is always in a dynamic state as new concepts, tools, and potentialities arise from the imagination of scientists and engineers and from the infinite possibilities and permutations of the electron tube and its many characteristics. In the highly competitive international technical situation it is necessary that the planners be ahead of the art, be imaginative and forward looking. Otherwise, there will never be any defense against aggressive enemies who may be willing to devote a much greater proportion of their scientists and engineers to such unproductive items as military equipment.

Thus, at any one moment in our technical history, it is necessary for designers to be working on equipment that may not go into service for several years. They will be working ahead of the state of the art. It is hoped that by the time the equipment must go into production the required components will have caught up with the art, will be ready for assembly into the equipment, and will be able to live in the environments that will exist at that time. But all of the ultimate conditions of use will not have been foreseen during the design phase; they can only be guessed at, and factors of safety included that, it is hoped, will take care of eventualities.

From past history of the rate at which higher and higher frequencies are explored and put to use, higher and higher output is secured from tubes at given frequencies, and components are developed that will tolerate higher and higher temperatures - from such history one can project ahead the time at which all of the several factors will fit properly and safely into the picture. But the designers have the responsibility not to accept jobs patently above and beyond the realm

of possibility judging from the past. It is unlikely that a whole new order of magnitude of power, for example, or a whole new octave of frequency, as another example, is suddenly to become useful or ready for exploitation. Figure 2-1 indicates the "gain-band figure of merit" for electron tubes during the past and gives some basis for a logical estimate of what can be expected in the near future.

From the overall viewpoint it is probably better to work on equipment that, when it gets to the field, will be somewhat behind the state of the art - but reliable - than to design apparatus that will be far advanced - but not likely to be in service much of the time.

Electrical and Electronic Circuit Design.

Poor circuit design is often the cause for later trouble. Only experience with military equipment under actual operation conditions can give the designer the feel for reliable design.

As an example, consider a three-phase power supply system in which the thyratrons were switched off so fast that the rate of application of the inverse voltage to the rectifiers far exceeded the manufacturer's recommendations. The result was rapid deterioration of the rectifiers, and continual replacement. After the trouble was located, a network was installed that reduced the rate of application of the inverse voltage, and much longer tube life resulted. Circuits intended for reliable operation should be thoroughly checked with respect to their operating margins.

Anyone active in the design or operation of modern military electronic equipment can probably cite numerous other similar examples. In order to design good circuitry it is necessary to do more than perform a superficial analysis of requirements to determine inputs, outputs, and general compatibility. All possible effects on circuit performance of the malfunctioning of any component, either by complete failure or gradual decline of performance level, must be considered.

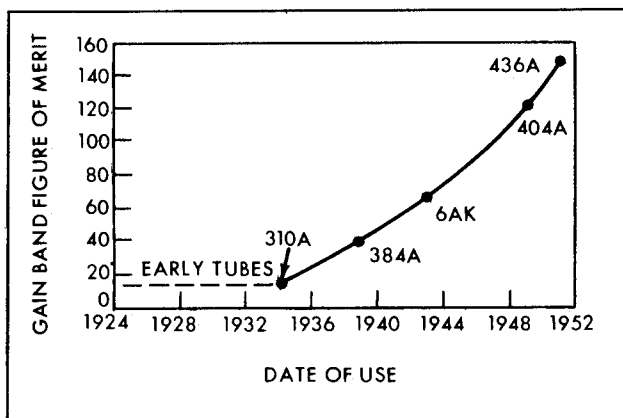

Figure 2-1. Electron tube "gain-band figure of merit" vs. date on which various tubes were used.

Components Application. Although studies of past failures in electronic equipment have led to the conclusion that tubes and other components are the cause of most cases of unreliability, these studies have shown conclusively that much of this kind of trouble has been due to misapplication of the components. In other words, the components were not used correctly.

It is necessary, therefore, that designers be aware of all of the intricate and interrelated conditions under which equipment will be forced to work, so that these conditions may be described to the manufacturers of the components ultimately to be chosen. The files of the components manufacturers bulge with case histories in which their products were blamed for equipment failures simply because the components were misapplied.

Some resistors, for example, exhibit hysteresis in their resistance-temperature characteristic; if overheated, they do not return to their original value. Many a resistor, therefore, has been ruined before the switch on the equipment is ever turned on because the resistor had been overheated in soldering it into place. The classic example is the 1/2-watt unit overheated by having a 500-watt iron held too near it for too long a time.

It is only natural that a designer, working in a laboratory, without much opportunity to see the end products of his work under field conditions, may unwittingly select components that are inherently unsuitable for military equipment.

This aspect of design is by far one of the major causes of unreliability. A later Chapter, "Component Parts," cites many examples of the misapplication of component parts.

Poor Mechanical Design. Electronics engineers do not, in general, have good reputations for building the best mechanical equipment. In the past, this has not been their forte.

Inadequate shock mounting, insufficient support for components, improper cooling, inaccessibility for maintenance - all of these items have been the causes for much unreliability in the past.

Complex electronic equipment is really not worth much to its user if it is always in drydock for mechanical repairs.

Complexity vs. Simplicity. At the moment the biggest factor is the greatly increased complexity of present-day equipment brought about by the greatly increased demands on electronic equipment. Planes fly faster and higher, all the things that tubes do must be done quicker and more accurately than man can possibly do them unaided. But "we are faced then with the anomaly that as we design our equipment to perform more and more astonishing feats of precision and complexity we have less and less confidence that it will perform at all." /1/

The numbers of tubes on a destroyer increased from 60 in 1937 to 3,200 in 1952. An aircraft carrier

will have about 12,000 tubes in operation at one time. And for every tube there may be 5 to 10 condensers and as many resistors. Each has its own chance of failure, its own life span, its own mortality figure. Is it any wonder that a 1,000-tube ground radar system operating under rather ideal conditions occasionally goes haywire?

From some quarters there is considerable demand for less complexity and more simplicity. This is a reasonable request; but even the simplest device - a safety pin, for example - can fail. If the catastrophic failures can be reduced materially, then a complex equipment has a better chance of operating - even if not 100 percent correctly - and of producing a result than a very simple device that either works or doesn't work.

The natural desire for universal equipment, stuff that will work on board a ship and in a plane or in the Tropics and at Thule, may work against a higher degree of reliability. Instruments can be made so universal that they won't work at all.

The struggle between complexity and simplicity must be resolved by proper answers to such questions as:

1. What must the device do?
2. What are the absolute maximum requirements?
3. Where and under what worse conditions must it perform its function?
4. How reliable must it be?
5. How universal in application must it be?

Complexity and Maintenance Relations. Using an unpublished work of J. Widrewitz, Rome Air Development Center, Mirman /2/ shows the relation of multiplicity of components and time to locate failures to reliability of complex systems. Of course, all such computations are theoretical, since not enough real data is as yet available to plot curves of actual service conditions. They are instructive nevertheless.

Mirman considers a system of:

Components	Failure rate	Replacement time (minutes)
50 tubes	1 per day	10
250 resistors	1 per 30 days	20
200 capacitors	1 per 30 days	20
1 human error	1 per 100 days	20
10 critical controls	1 per 30 days	5

and plots the system reliability as shown in Figure 2-2. Here system B, having 3 times the complexity of system A has lost 8 percent of its reliability compared to system A and system C, being 5 times as complex, has a reliability 38 percent less than system A. The improvement in reliability that can result from increased ease of failure location is also shown on the chart. Note how rapidly system C reliability drops as the time required to locate troubles increases. The need for trouble localizers and indicators, as

well as automatic testing devices, becomes very clear upon examination of system C data.

Universality - Vice or Virtue? The single-minded idea that a universal equipment, useful for all services and under all conditions, would knock out many of the reliability problems, is likely to be an extreme oversimplification. In a particular AN equipment, the engineers were saddled with the requirement that the equipment must work properly under all U. S. and British frequencies and voltages. Next, it was to operate properly with all existing and obsolete systems; it was to be truly universal. This equipment never "jelled" into workable apparatus until it fissioned and blew apart into discrete, specialized units, each useful for its particular job.

Universality of this order offers little or nothing from the reliability standpoint. The Working Group on Technical Design, AGREE, in its February 24-26, 1954 meeting commented on regulations SR 105-85-2 and AFR 100-12, which stress a minimum number of types of equipment to satisfy the needs of various branches of the Services. In this manner, "undue stress on the minimum number of types of equipment of universal character by compiling many diverse requirements into a single design may result in an equipment that may not provide any single user with equipment having maximum reliability."

There is no doubt that if the designer is forced to start his work from the standpoint of holding certain characteristics, such as weight, size, cost, or watts, to a minimum he cannot, at the same time, design for maximum reliability. Until the interplay of all of these diverse factors is better understood, and better documented by engineering data, designers will be forced to work in the dark, using their best judgment and relying on the almost certain fact that the equipment, in the end, will work worse than was hoped for!

It is undoubtedly true that highly specialized equipment will do its job better than equipment designed to do several jobs, or the same job over a wider range of conditions or requirements. Thus, a 10-mile radar may be developed that is practically ideal from all aspects - including reliability. But the nontechnical echelons that set the requirements may then decide that the range is to be pushed to 15 miles. The end product may be a radar that is only X percent as good as the 10-mile equipment, or that may work only Y percent as much of the time.

Much can be done toward standardization of components and of certain electronic subassemblies - power supply systems, for example - but the concept of universality can be overworked.

The advantages of a truly universal system are obvious. Identical equipment for various Services would cut down the number of stock items needed, reduce cost, reduce man-hours used in designing competing systems, ease maintenance because of better training on few sets instead of limited training on many equipments, with the result that reliability all along the line may be improved./3/ The advantages, however,

must be weighed against the factors on the other side of the score card.

The desire for universality exists among the vendors as well as the users of components, and may lead to too general and too broad specifications. For example, a tube manufacturer interested in selling vast quantities of tubes to many manufacturers may

propose a specification to the military that will enable him to maintain a single "line" of tubes. This will call for fewer tube types, each with wide limits. Tighter specifications, however, call for tighter manufacturing controls, higher scrappage, higher costs, greater uniformity over a narrower range of limits. Thus, the designer knows more exactly what the tube characteristics will be, once they have been installed in the equipment.

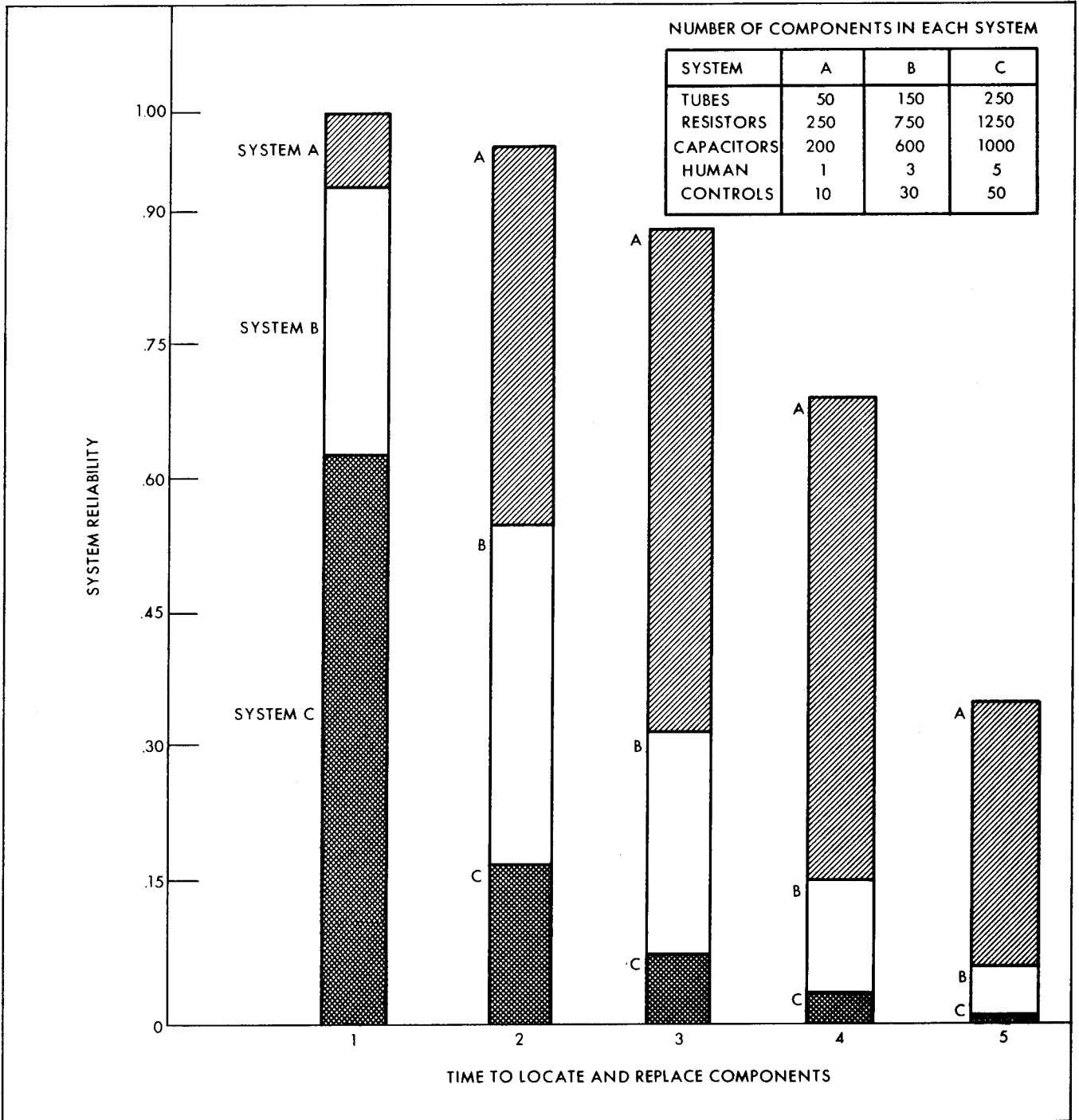

Figure 2-2. System reliability as a function of system complexity and time to locate and repair component failures

Field Experience. Designers' lack of knowledge of field conditions under which electronic equipment will be used is often cited as one of the most troublesome aspects of the reliability problem. Opportunity and time should be allowed for project engineers to visit field installations; but long before this time occurs much can be done to acquaint engineers with what the conditions are likely to be.

The Working Group on Operations and Procedures, AGREE, at a meeting in Cocoa, Florida, February 24-26, 1954 recommended "a program in which the contractor's project engineers would receive a complete briefing relative to the use of the equipment in the field by both technical and military operational personnel. These briefings should include:

1. Explanations for the reason for the development, specific objectives to be met and environmental conditions under which the equipment must be stored, shipped, installed and operated.
2. Discussions on the shortcomings of similar equipments and recommendations for improvements with copies of technical and maintenance manuals, maintenance records, and information bulletins and unsatisfactory reports furnished to the contractor for study.
3. Descriptions, illustrations and training films showing how similar equipment is handled from the contractor's plant to the field.
4. A visit to the field installations where contractor personnel can observe actual installations of similar equipments and discuss problems with the using personnel.
5. A visit to witness field tests in which similar equipment is used under closely simulated combat conditions."

Lack of knowledge of field conditions can be a real handicap to the designer and producer of military equipment. In one case repeated reports of shipping damage caused concern about the mechanical strength of a heavy piece of ground-based equipment. Prototype equipment had withstood a 25-g shock test, and it was felt that normal handling should cause no trouble. A small impact recorder was attached to one of the equipments inside the shipping case. The project engineer arranged to be present when the shipment arrived, and watched the case dropped four feet from the truck to a concrete floor. When the case was opened, the impact recorder registered in excess of 35 g.

## PROCUREMENT AND PRODUCTION CONSIDERATIONS

Systems Versus Component Buying. The following material, representing industry's viewpoint on present-day procurement practices, is taken from a

talk by Glen McDaniel at the Symposium, Progress in Quality Electronic Components, Washington, D.C., May 5, 1952. "A substantial portion of major electronics equipments procured by the military constitutes part of a systems operation. The absence of one part of the system may render the whole system useless. . . . The Services have long followed the practice of having different portions of the system produced by different contractors who have no relation with each other. . . . In many cases the procurement is done by different officers in the same Service agency. One officer procures from contractors A, B and C an airborne installation and another officer procures from contractors D, E and F a shipboard installation, despite the fact that the two equipments must function together.

"This policy contrasts sharply with the practice of most industrial firms in their civilian business. (Here) a single person is given complete authority and responsibility for conducting a given program. . . . He has the authority as well as the responsibility. A military-industry Task Group on Project Responsibility (has) recommended that an electronics system be treated as a whole and that specific authority be given to a single project officer to handle the solution of development, design, procurement and subsequent service and installation problems of each system. It urged that whenever possible the development and procurement and subsequent service and installation of a complete system be handled through the medium of a single prime contract based on a system specification."

Lowest Bidder Practice. While it is recognized that the practice of letting contracts to the lowest bidder holds down costs and avoids criticism of creating or tolerating "lush" contracts, it is a reasonable assumption that one never gets much more than what he pays for. Under this system, the several possible contractors use their ingenuity — in order to get the job — in cutting costs, with the result that the one who cuts the most corners is very likely to get the contract.

It would be most refreshing, and probably highly worth the effort, to determine the amount of money that can be expended for an equipment and then to invite the potential contractors to bid on the basis of how much they will offer for the money. In such a situation, the ingenuity of the concern would be in an entirely different direction; imagination and skill would be devoted to improving the product rather than to the stultifying endeavor of producing the product cheaply.

Under no type of contract can the project engineer or the Service he represents compel manufacturers to build reliability into the ultimate equipment. Reliability is a function of time, and by the time the lack of reliability shows up, the production run is over, and nothing can be done about it. No guarantees of reliability can be anything more than a statement in the specification, for the simple reason that nothing can be done to penalize the manufacturer if his equipment fails to come up to this paragraph in the specification.

Reliability must be built into the equipment at the design stage. This calls for the best of components; and the philosophy that demands low costs for everything that goes into the equipment is not conducive to purchase and use of the best of materials, methods, or parts. The whole philosophy and approach is in the other direction.

First Cost Versus Total Cost. As soon as reliability as a parameter begins to appear in equipment specifications, the cost of the equipment goes up. This cost is caused by the higher price of components of greater reliability — components that will tolerate greater temperature ranges, greater overloads, or other factors that cause failures.

The first cost of military equipment, however, bears little relation to the total cost — original cost plus maintenance — and there is no doubt that the reliability clause in future specifications will reduce the overall cost by reducing maintenance.

It is reported /4/ that more than \$240,000 per year was cut from service costs on one aircraft communications equipment commonly used in commercial aircraft by the development and use of one special tube to replace the 6AK5 in airborne service. The individual tubes cost more than standard products, but the reduction in service man-hours easily made up the difference. In time of war, freedom from service troubles — reliability — would be worth all the money that would be required for the difference in price between ordinary equipment engineered at lowest cost, and reliable equipment that stayed on the air and required fewer men to keep it functioning.

Considering the time required to locate and replace defective components, it always pays to use components that are less likely to fail. In the long run it is probably cheapest to use the best equipment that can be bought.

Reliability Clauses in Contracts. Let us assume a typical case. A certain equipment has been in production long enough to indicate that capacitors will not last very long — say a few hundred hours — under actual field conditions. The capacitor manufacturers are able and willing to furnish capacitors that will stand up much longer — but the cost will be much greater than for conventional and present units. The production run on this equipment is about over and a new contract will be negotiated for a new batch.

The contracting officers will put the new production out to bidders and none of the newcomers will know that the reliability with existing capacitors will be poor. When the bids are received, the offer of the present producer will be much higher than that of the newcomers because he alone knows what has to be done to produce the desired life — he must buy more expensive condensers. His bid is quite likely to be rejected in favor of a lower bid. And the past experience of the prior manufacturer will be lost.

In an effort to keep costs down, vendors have been known deliberately to bypass certain tests during production and final testing. Manufacturers striving to achieve high reliability should not be penalized for having higher costs for these reasons. The purchasing department should be notified when a high degree of reliability is necessary, so that the higher costs of making the required production tests and inspection will be taken into account in accepting bids and awarding contracts.

Realistic Specifications. The whole process of designing, on paper, a piece of required equipment must bear the closest scrutiny of experienced and hard-boiled leaders. The specifications should be adhered to once they are set. It is most discouraging and virtually impossible to produce creditable equipment under specifications that change at the whim of anyone along the line, from the top echelon down.

Numerous projects have bogged down because new requirements were continually being invented. In one case the equipment was developed for one Service organization and was working satisfactorily in the preproduction stage. Another branch of the Services saw the equipment and was delighted with it — provided it would work just a little bit differently. The requirements were changed to suit the newcomer; and another eight months went by before either organization got its equipment. At this point it was not especially good for either.

The specification writer who demands a relay that will function for 1,000,000 operations when he really wants a relay good for 10,000 operations is only kidding himself.

Speaking of capacitors for high-temperature operation, Schell /5/ comments on the "extreme importance of realistic, accurate knowledge of temperature-time conditions in electronic equipment when selecting capacitors. Former rule-of-thumb additions of safety factors in terms of temperature can be easily rule out a capacitor which actually might well and safely serve the purpose desired. If maximum temperature possible is determined to be 130 C, it should be so stated in requirements — adding 25 C for 'safety' may make it impossible to obtain desired characteristic in any capacitor available. Length of time these maximum temperatures will exist should also be considered and stated in procurement documents, preferably in terms of duty cycle."

It is certain that the future specifications for equipment will contain requirements for reliability. At the moment, performance, cost, size, and weight are cited, but in time reliability will surely be one of the prime objectives in development. It is the belief of many in the components industry "that if reliability were established as a basic requirement equipment engineers would approach this problem differently. They would exercise more care in the assembly of components; they would study the limitations of components more carefully and use them in ways which would not tax them unduly; they would devise systems and circuits, perhaps unorthodox, which



would permit the use of components with wider tolerance and variations; they would use more rather than fewer, larger rather than smaller components to achieve reliability. The burden would then be more equitably divided, and the incidence of unreliability considerably reduced."/6/

Examples of poor specifications will point up this discussion. A scanning oscillator was designed in which a microswitch was operated once each second by a cam on the oscillator tuning mechanism. Careful scrutiny of the requirements indicated that the switch was guaranteed for a number of operations that amounted to just two weeks of service. This is a case of a high class component used under circumstances for which it was never intended.

Specifications and ability to produce are related in ways which the specification writer often does not see. A certain specification calls for certain dimensions with no known available source. This specification calls for a 1/2 - inch minimum thread length, but no known requirement for more than 1/4 inch exists. Existing parts have 3/8 - inch thread length. The specification also calls for one hole in each terminal but does not indicate whether more will be permissible.

In 1942 military specifications established a 25-lb limit for 1-kw, 400-cycle MG sets for use with early microwave equipments. No supplier was able to build a unit that would run reliably for 100 hours. One supplier ignored the specifications and produced a very good set weighing 36 lbs.

Dimensions vs. Performance Specifications. Reliability of microwave components seems to be basically good. When unreliability does occur, it is generally due to the use of dimension type specifications. Almost all microwave specifications are of this type, requiring only conformance to certain specified dimensions, which have been found by previous experience to work satisfactorily. However, there is no guarantee that additional pieces made to the same dimensions (within the stated tolerances) will result in equally satisfactory performance.

In this case specifications written on a performance, rather than on a dimension, basis would be better. Actual dimensions, other than mating faces and overall size, are of little importance. The essential criterion for acceptance is — how well will the equipment work?

Military Specifications. Military specifications for components can work to the disadvantage of reliability only if the circuit designer works on the premise that any component with a military specification number attached to it will be the best for his particular job. Military specification components, in general, are much better than commercial radio and TV components, but if the designer leans too heavily on them, he will at some time build into his equipment some components that are not suitable for the particular application. If long life is required, some inspection and testing beyond the requirements of military specifications are usually necessary.

Standardization. The timid designer can go wrong in accepting only components, circuits, or parts that have become "standard." If he pays attention to the types of components he selects and uses the best judgment and experience that can be brought to bear on the problem, even though the components selected may not be standard from a military specification standpoint, reliability of the equipment will probably be good so far as the components are concerned. Any equipment that goes into production brings with it some implicit "standardization," because whatever is used is "standard" for that equipment.

Field Trials. Commitment to production prior to full field test is one of the greatest causes of field trouble. In a particular equipment now in wide use, a report states "there have been approximately 30,000 drawing changes on the . . . portion alone since the prototype model. The numerous equipment changes mean that the maintenance man never quite catches up with the latest technical information. The supply rooms are always short of urgently needed parts. The training can never be up-to-date and, consequently, the overall result is inadequate support in the field."

There is not the slightest doubt that the transition from the experimental stage to the production phase should be more gradual than was the case in this important system. The means of effecting this gradual transition poses problems that extend from the top to the bottom and will require attention at every level of responsibility.

Various estimates have been made of the time required between breadboard model completion and the time when deficiency reports become available from the field. The length of time naturally depends upon the kind and complexity of the equipment. If, however, the entire production run is completed before any field data is available, then the opportunity to iron out "bugs" in later models or productions is lost. In general, it seems to require upwards of two years before a complex system is in top working condition, so difficult is it, in advance of extended field tests, to know all the things that can be wrong with a piece of machinery developed and produced in laboratory and factory environments.

Engineers differ on one matter — whether or not there should be redesign after production has begun. Some feel that each new design change brings with it further unknown potentialities for field failures. They declare, therefore, that changes during production should be limited to minor alterations in circuit, or substitution of components. Other engineers have the opinion that every field failure gives information that should be put to use with the ultimate goal of a mechanism as perfect as is possible.

It is certainly true that equipment that fails on life test in the manufacturer's plant gives the design engineer a wonderful opportunity to circumvent future failures.

Research vs. Production. There is a considerable body of opinion that firmly believes that as

close liaison as possible should exist between the development of equipment and its final production. The practice of contracting to one organization for the research and development and to another for production of the actual equipment has many disadvantages. During the research and development stages much useful background and experience is gained that can be brought to bear upon final production. Where the procurement contract is with an organization totally different from the one that developed the equipment, all this background and "feel" for the equipment is lost.

Production Problems. A complex military system is made up of a vast number of individual parts, some of which may be new and untried. Engineers seem to have a highly developed skill at making circuits out of material that has not, as yet, existed and special parts that are new and for which there is little or no production. There is no doubt that such practices compound the reliability situation because untried components have not yet demonstrated their reliability. On the other hand, it is recognized that military equipment is special equipment, requiring special parts that may exist only in the design and development stage for several years.

The designing engineer is encouraged to use standard parts in heavy enough production so that their individual life histories are known. In this manner the approximate reliability of the assembled parts may be estimated.

The engineer must keep in mind the lead-time required between the handmade models of any component and the production-line model when the final equipment goes into the factory. By this time say two years after the special part has been designed, the manufacturer whose engineers produced the special part may be out of business.

With all this in mind, it is extremely important for the equipment designer to keep the components manufacturer in close touch with the time aspect of the situation; the component manufacturer must have all possible lead-time. He should be consulted at the beginning and at all stages of the design. Often he can recommend other and better components than the engineer had planned to use.

The components manufacturer will have to translate his handmade model to a production model; he will wish to make enough so that proper life tests may be run to completion; there is much that he will wish to know before his name goes into a final piece of equipment which may, or may not, have a good reputation for reliability.

## OPERATION AND MAINTENANCE PERSONNEL

The relation between the quality of the men who must maintain complex equipment and the reliability of the program is only, as yet, dimly seen by higher echelons. Down the line it is firmly believed that the high turnover rate among maintenance men, their reluctance to reenlist, their low morale,

the lack of incentive, and the need for an attractive career in high-class maintenance have much to do with the down time of electronic equipment. There is very little chance that such equipment will become simpler; the rapid pace of arms development, due to international competition, will continually bring new concepts, new jobs to accomplish, and new barriers to be overcome by electronic equipment. The maintenance man, therefore, needs a new classification, he needs to be shown that it often is more of a feat to repair equipment than to design it, and that he can find much satisfaction in so doing. But the job he does must be appreciated in concrete ways by the higher echelons.

Methods of attracting more and better interest in the field of maintenance and service are within the inventive abilities of military and civilian people. It is not impossible that proper orientation would develop maintenance into a science in its own right, so that really high-class men would go into it as a career.

The inner satisfaction at being an expert in something must be tested against the current practice of giving maintenance men a smattering of everything, and of transferring them as soon as they are able to move with assurance into trouble spots that show up with any particular equipment. The Final Report (15 July 1953) of the Navy-Bell Laboratories Component Reliability Program performed under contract NObsr-52480 includes the following paragraph from a field report dated 22 June 1953:

"Maintenance was handled by the electronic technicians on all equipments with few minor exceptions. In general the technicians in charge were of good technical experience; however, during the 18-month period quite a number of men were replaced by new, inexperienced men. Some had been to school but had no practical experience, while others were learning from scratch. As soon as a man was fairly well acquainted with a certain type of equipment he was transferred to another type in order to broaden his education."

One of the reasons for an excellent reliability record for certain GCA equipment operated by the Civil Aeronautics Administration is stated to be directly related to the CAA maintenance staff. Thus "maintenance personnel are well qualified and experienced. Training by means of resident and correspondence courses is constantly in progress. Personnel turnovers and transfers are low enough that the maintenance technicians become very familiar with the equipment for which they are responsible."

However willing the maintenance personnel may be, if they are poorly trained or equipped, or are given inadequate instructions, trouble will result. For example, a rather delicate electromechanical recorder was subject to frequent damage as the result of adjustments attempted by insufficiently skilled personnel. The real trouble lay in the maintenance handbook, which should have put more emphasis on the delicate nature of the equipment and the precautions necessary when making adjustments or repairs.

## REFERENCES

1. Benner, A. H., and B. Meredith, Designing Reliability into Electronic Circuits, Report No. EM-4208, Radio Corporation of America, Camden, N. J., 27 October 1954.
2. Mirman, I., "Reliability of Electronic Equipment," National Airborne Electronics Conference, Dayton, Ohio, 12 May 1952.
3. Brown, A. S., Professional Group (PGANE), Transactions of the IRE, September 1953.
4. Electronic Equipment Construction, Terminal Report, Contract N7onr-32103, Stanford Research Institute, 1 June 1953.
5. Schell, J. W., "Capacitors for High Temperature Operation," Proceedings of Symposium, Progress in Quality Electronic Components, May 5, 6, and 7, 1952, p. 75.
6. Marsten, Jesse, Resistor Reliability - Whose Responsibility?, Eastern Joint Computer Conference, December 8, 9, and 10, 1953.

# CONTENTS

## chapter three **systems aspects**

Systems Approach

Heterogeneous vs. Homogeneous Systems

Systems Design

System Troubles

What Can Be Done About Reliability

The Designer's Job

Information Feedback

Maintenance Problems

Unitization Philosophy

Design Principles

Circuit Standardization

Steps Toward Reliability

Reliability Programs for Manufacturers

Standard vs. Special Parts

Field Failure Reports

# chapter 3

## SYSTEMS ASPECTS

Military electronic equipment can no longer be considered as individual isolated pieces of apparatus, designed and operated without much regard to other pieces of apparatus; it must be looked at as assemblies of equipments into integrated systems. This concept must affect all technical thinking from the beginning (the idea) to the end (maintenance) of any electronic material; from the top echelon to the man in the rear ranks.

"The very nature of the problem has forced the military agencies to develop what is called the "system approach." They recognize that they are no longer dealing with a series of weapons more or less independent of each other, or at least easily adjusted to each other, as might have been true some decades ago when the Navy was seeking to improve its battleships and at the same time to improve the guns to be mounted on their decks. All this has been changed by modern techniques of communication, by the speed and power of modern weapons and — most important — by the fact that scientific development is no longer a short-term job for the engineer alone, but a long-term job for a team of scientists and engineers combined.

"If all these (scientific) things are to interlock with one another and into the tactical plans of combat leaders and the production plans of the industrial mobilizers, they have to be planned as a closely knit system and developed as a system."/1/

Within this framework — "a long-term job for a team of scientists and engineers combined" — a new kind of engineer will develop, a reliability engineer, one whose primary concern is that of keeping the equipment functioning. His contribution to the teamwork will start with the basic concepts of new equipment and will carry through to the maintenance and repair stage. Reliability will be as important an aspect of equipment as structural strength, portability, or electronic effectiveness.

To be effective, each member of a team must have the confidence of every other member; each must know the ultimate aim of the job and all the conditions that may define, make possible, or limit that aim. There must be complete freedom of communication, total feedback of knowledge, one to the other. The designer of equipment, must, therefore, know what the apparatus is for, where and under what conditions it is to be used, how it is to be transported to where it will be employed — all the facts that may enter into his thinking of the new machinery. It is cheaper to plan all these matters at the beginning than after the material is in the field, where changes are difficult and costly.

The Systems Approach. "System design is the integration of component engineering, circuit and mechanical design and operational planning by logical methods. In complex electronic systems the design and manufacture of components must be thought about and analyzed as an integral part of any thorough system analysis."/2/

Elmendorf, speaking from the Bell Laboratories experience in designing the L3 coaxial cable transmission system, says that the "problem of deciding what component parameters will be finally achievable at what cost must be faced in the earliest stages of the system planning. This problem cannot be avoided merely by letting the system design wait until the component designer has completed his work, since the component designer must be guided by the needs of the system and vice versa. The problem is to devise methods for gradually crystallizing a system and its components so that the objectives are achieved in the most economical manner taking into account such factors as development cost, manufacturing cost, maintenance costs and the value of having the end product available when required."

The system design, therefore, is a series of analyses and development stages, a continual review and reappraisal of the system objectives, of the theory

and experiment, of the ways in which these matters must be compromised by the realities of what can be produced in the way of suitable components. At the end, if the system planning has been well done by clear and realistic thinking and by good teamwork, the system will be a well integrated and thoroughly welded assembly of equipments making best use of the best available components.

In the first stages the whole picture may be pretty hazy, it may consist of blue sky properly tinted by the accumulated and cumulative experience of the designers. The areas of ignorance will be fairly evident.

In the next stage some of the haze will have been dissipated, some of the areas of ignorance will have been eliminated, and a clearer picture can be had of what ultimately will be possible and what will be needed to make it possible. By a continuous interchange of ideas and concrete technical data the essential watering down of the original hopes can be effected. The needs in the way of components will now be clearly evident. And what components can do will be evident.

At the final stage, all these analyses, experiments, judgments, and compromises must come together into a system of individual parts that fit together.

Heterogeneous vs. Homogeneous Systems. The concept that electronic equipment must work with other equipment, including the human component, and must be considered as part of a system, has been slow in developing. It was natural in the early days of aviation electronics that the aircraft people and the radio people pursued their own well-trodden ways, with each pretty well satisfied with his own accomplishments. A radio set for a plane was simply another radio set, perhaps advanced in concept and performance, but too bulky, too heavy, and often too hard to operate. The radio set and the plane were not conceived as a system.

"All considerations of weight and balance, as well as streamlining, were thrown to the winds as more and more electronic equipment was crammed into aircraft not at all suited to carry it."/3/ At this juncture, the aircraft industry went into the electronics business in self-protection, designing and building its own radio apparatus. "We can no longer patch together a weapon from a conglomeration of radars, computers, guns, and an aircraft. We must create a . . . system tailored to the specific tactical application which the military requires."/3/

With the development of the systems approach to military electronics, the day of complex gadgetry, which depends upon new concepts, new components, and new frequency bands suddenly opened up, is giving way to a more refined but no less complex concept, in which all the component parts are designed to work together to form a piece of equipment and all the pieces of equipment to work together in harmony to form a weapons system.

Under such a broad concept, reliability becomes an important design parameter and must be considered along with all the other requirements. If the performance of the system is realistically appraised by eliminating some fantastic requirements, it may be found that the necessary performance can be attained with some capability left over. This excess capability may be converted into greater reliability, with the result that a much better "system" is attained.

Keeping all this in mind, however, the designer must always be faced with the fact that the electronics art is unpredictable — at any moment a new major tool may become available and alter profoundly all past capabilities. Radar, made successful by the pulsed magnetron, was one of these great breaks through existing barriers.

The unitization concept, described below, may make it easier to employ these unexpected dividends of past research and discovery. Appreciation of the work and mental equipment and attitudes of the scientist will ensure that early warning may be given of new things to come, instead of having them burst suddenly upon the engineers, or instead of our hearing about them from unfriendly lands.

Systems Design. Most engineers are specialists in receivers, transmitters, antennas, or elements of these individual parts of systems. It is difficult for such specialists to conceive of the system as a whole and to plan on such a wide basis — but it is important and necessary, especially for ground installations, where the complexity may be much greater than aloft or at sea. It is probable that a systems engineer should be made responsible in each laboratory or manufacturer's plant to have the systems aspects in mind at all times. Some of the questions he should be able to solve are as follows:

1. What is the height of antennas at airports and the layout for minimum hazard?
2. Will there be interference of one equipment to other equipment because of conflicting frequencies, excessive field strengths, poor layout of power cables, proximity effects, mutual impedance between antennas, and so forth?
3. What special frequencies are required for the new equipment, are they available or already overloaded, what is their interference-creating ability locally and at a distance? How secure are they?
4. How should system units be interconnected — coaxial cable, radio, open-wire lines? How many circuits will be necessary? What is the information handling ability of the various types of information transmitting methods? Voice vs. code? Visual vs. aural methods? Telephone vs. teletype? What will the crosstalk problem be?

5. How flexible must the units be? Are they always to be located 20 miles apart? Or will someone want to jam them all together into a small area?
6. How portable must the units be? How often transported, and by what means?
7. What is to be the duty cycle, 24 hours per day? Intermittent?
8. What are going to be the power-supply problems? How much power? What stand-by power must be provided? How long to shift from local 60-cycle supply to stand-by and what adjustments must be made during the transition?
9. How much inter-Service coordination is desirable or necessary?

Within the concept that a system is an assemblage of electronic equipment to perform a certain function, many things have to be kept in mind. It is not axiomatic, if the individual parts or equipments have good reliability, that the system will have good reliability. The system must be planned that way. The overall reliability depends not only upon the individual reliability of the parts but also upon how well they work together.

Switching transients in one part, for example, must not be fed back through the power supplies to create spurious effects in another part of the system. When the output of one part feeds another part of the system the impedance levels must match to eliminate, for example, reflections on pulse lines, which can cause unwanted effects. Pulse lines must be properly terminated. Circuits that are designed to work into a certain load will not operate properly if some of that load is removed and, therefore, if portions of the system are removed for maintenance or tests, dummy loads must be provided to simulate the load removed. In high-speed pulse circuits where pulses are piped over transmission lines between various sections of the system, the timing of the pulses may be seriously affected by the length of the cable involved, and if timing is an important factor in the system operation it will not show up in the testing of the individual pieces of the system.

The system is not always as good as the excellence of the individual parts would suggest to the inexperienced engineer.

Marginal checking in any of its forms enables the systems operator to keep a running picture of the probable reliability of his system so that he can anticipate troubles before they occur and can eliminate them before the system fails in service. This is only one of the techniques that the designer can utilize to improve the reliability of systems as a whole.

System Troubles. When planned as a complete system, a compilation of units has the best chance of operating properly. Coordination of the numerous systems of communication and defense at the design stage will produce the best overall effect. A defense system made up of early warning radar nets, picket vessels at sea, antiaircraft artillery, missile systems — even the methods for warning the populace — can be most effective if planned as a whole and if the designers of the individual units know the whole picture.

Very elemental things can ruin a system made up of disparate parts brought together without adequate planning. In one installation HF and VHF sets were brought together. The HF transmitter had not been designed to work into a shielded antenna lead, so that the long unshielded lead brought into the common housing for all the equipment strong 12-mc interference, which paralyzed the VHF equipment.

In another situation a single-wire interphone setup caused much trouble to other equipment. Changing to a two-wire circuit eliminated the difficulty.

#### WHAT CAN BE DONE ABOUT RELIABILITY?

In the preceding chapters some of the general and specific causes for past and present unreliability have been covered. In the following pages some of the things the designer can do to improve the reliability of military equipment and electronic systems are pointed out. The system aspect is particularly important for the designer of ground equipment because ground installations are very likely to be much broader in concept, scope, and purpose than airborne or seaborne equipment. Such ground installations may involve, within a given area, every possible type of electronic equipment, from the simplest two-way wire telephone to the most complex warning or gun directing systems; they may cover the whole gamut of radio frequencies presently usable. The problems of mutual radio interference and of man-made noise must be understood and overcome. The whole problem of properly integrating the many portions of a ground installation comes into sharp focus, a problem that must be solved before the installation is made, and not after everything is in place and causing mutual trouble.

The Designer's Job. Only a few of the items the designer must have in mind are indicated below, but they are important. Every engineer can add to this list additional items that his past experience indicates are worth doing.

The designer must:

1. Recognize the systems aspect of military electronic equipment.
2. Get knowledge that is as complete and up-to-date as possible on past failures and the reasons for the lack of reliability of the equipment.

3. Learn everything possible about what component parts will do under all conditions of possible use. He should not blame the component parts for failures if they are used incorrectly.
4. Learn from and beyond the specifications for new equipment all that is possible about the purpose of the equipment, and the conditions under which it will be stored, transported, and used in the field.
5. Compare the time of delivery of production equipment with the best guess possible on the state of the art as of that date. He should not rely on the hope that component parts, or circuits, will be available when needed, and not get out on a limb by agreeing to design equipment far beyond possibilities of accomplishment.
6. Practice simplicity wherever possible. A simple piece of equipment, perhaps one whose principles of operation are already well known, is easier to repair than a complicated one.
7. Design conservatively, using component parts conservatively.
8. Never forget that it is not the designer who is going to maintain the equipment, or that the maintenance man may not be located in a comfortable laboratory with plenty of time and lots of high-priced help.
9. Try to visualize the test equipment necessary as the circuit design proceeds; if possible build in the test apparatus.
10. Try to visualize the man who is going to operate the equipment — never forgetting the new trend toward "human engineering."
11. Avoid special parts; avoid circuits that require handpicked tubes to make them work.
12. Use interchangeable parts that are easily replaced.
13. Plan on fail-safe features.

Information Feedback. All reports now being written on the general subject of reliability emphasize the importance of feeding back into the design-to-operation chain all possible information gained in the field. Manufacturers of component parts and equipment want and need such data, so that future component parts and equipment can be designed for greater reliability. This feedback should not be restricted to the individual Services or laboratories or manufacturers; it should be generalized where possible and pooled for the benefit of all. A central clearing house for such information would be a real asset.

From the Bell Laboratories-Navy Component Reliability Program, and from the Rand and Vitro reports, engineers can learn much of what has happened in the past and can learn what to avoid in the future.

If failure reports from the field come to the manufacturer before production ceases, corrective measures may be taken at once.

Feedback is exceedingly important. The present security system plus industrial secrecy works against it, however. There is a case on record of a man who made all of the particular component parts for an important instrument without being told what the tubes were to do and who avers that he could have done a better job if he had known the essential facts. In this case no security was involved - just lack of appreciation of the value of a man's knowing what he is doing and why.

Maintenance Problems. To lower the cost of maintenance in terms of manpower, and at the same time to ensure greater reliability, calls for good design and the use of good component parts carefully selected with adequate factors of safety. Even then the cost must be assayed. To be sure that all apparatus is ready for use at the time desired would call for a tremendous force of maintenance men who are constantly at work on the equipment prior to actual use. Such labor would come under the general term of preventive maintenance - forestalling actual failure. It would call for most intimate knowledge of what each portion of the equipment would do as its component parts get old and tend to approach actual breakdown. At what point in the life of a tube, resistor, or capacitor should it be replaced? Knowing the average time to approach this point, how many men and how many hours per equipment would be needed for preventive maintenance? And the 64-dollar question is - is it worth it?

All equipment and all parts of equipments are not like thyratrons, which either conduct or don't conduct. Much equipment merely suffers a slow degradation of service as its component parts get old. Is this degradation noticeable, and, if so, at what point? If an adjustment must be made every so often to bring the apparatus up to topnotch condition, should the adjustment be calibrated in some way so that the rate of degradation can be logged? A television receiver, for example, must have certain sync adjustments made throughout the life of the component parts, including tubes. Finally the receiver won't sync at all and a replacement must be made. If the adjustment is calibrated so that when the dial or knob reaches a given point its replacement can be made then rather than to wait until sync fails completely. But is it worth it?

Is it worthwhile to maintain logs of such adjustments, to tie up the manpower and man-hours in anticipating and preventing complete failure?

If the summation of the slow drifts of characteristics of tubes and other component parts can be translated into a single, or few, physical manifestations, then facilities for testing each unit of an equipment each time it is used will pay off. This is the principle of marginal testing "where the equipment is subjected artificially to changes in currents and voltages in such a way as to narrow the margin of safety." /1/ This technique will prevent the actual failure of



the equipment in use resulting from such slow drifts. In the majority of cases the effect of drifts in components and valves is equivalent to a change of the supply voltage. The use of common transformers, rectifier and stabilizing circuits for a complete channel will facilitate the marginal testing of the channel."/4/

In all these matters the time and manpower required to prevent failure must be judged against the importance of having the equipment ready when wanted.

## UNITIZATION PHILOSOPHY

The direct approach to greater reliability involves the improvement of component parts, proper selection of component parts for the job to be performed under the known environmental conditions, proper application of the component parts, proper electrical, mechanical, and circuit design, and proper manufacturing methods as evidenced by quality control inspection.

After these direct methods have been applied to a new development, it is necessary to consider how the equipment can be quickly and economically repaired after failure occurs. Easy location of the failed component parts and their easy removal and replacement are aspects of this part of the reliability battle. Location of parts most likely to fail in the most accessible portion of the equipment is one technique.

But after these fairly obvious techniques have been employed one reaches the limit in ease of maintenance. A new order of magnitude of replacement facility needs a new order of construction, a new concept. Unitization seems to be one of these new concepts, one which is just at the point of being adequately explored.

Benefits of Unitization. The modern techniques involved in unitization are indicated in other portions of this book. The general philosophy and the advantages of the idea from the systems standpoint are given here.

In broad outline, unitization consists in making standardized identical units of certain electrical functions, such as limiters, flip-flops, power supplies, IF amplifiers, and converters and, in the ultimate, these subassemblies will be made on automatic machinery. The units will be easily assembled into combinations of functions, and will be inherently reliable, but may be unrepairable, that is, expendable. Every modern technique, such as printed circuits or embedment of component parts, may be employed in manufacturing them.

Brush /5/ cites the following advantages:

1. New equipment design will be simplified and design time shortened by use of previously developed and "debugged" basic building blocks.

2. Current equipment can be modified with newer and better functional units replacing older heterogeneous assemblies of component parts. Thus, magnetic amplifiers and transistor units could replace their older counterparts.
3. The standard building blocks can be built by highly mechanized methods instead of assembled by handwork.
4. The procurement base will be broadened, and the producing capacity of the industry increased, since small companies can be encouraged to build the standard subassemblies made up of few parts.
5. Reduction of maintenance personnel will increase the manpower available for design or production jobs.
6. Fault recognition, location, and correction will require less time.
7. Training of maintenance personnel will take less time and cost less.
8. More effective means of heat transfer and more efficient thermal designs can be incorporated into the subassemblies than is possible with present techniques.
9. Component parts will be used in predictable controlled environment.
10. Reliable and standardized circuitry will enable the use of component parts whose variable parameters will have least effect on circuit function.
11. The building blocks can become a more uniform and "quality" item, with fewer performance variables or small functional tolerances.

Design Principles. In the design of these subassembly units, the Navy has laid down certain guidelines /5/ as follows:

1. Units will be standardized in functions, physical dimensions, and circuitry, so that they may be interchangeable and repairable with identical parts.
2. Internal construction will be as simple as possible and will be designed for mechanized production.
3. Highest quality component parts and tubes will be used.
4. The units will be used in as many equipments and systems as possible.
5. Complex functions will not be standardized. The units will be one- to three-tube devices.

6. A standard unit will continue as standard until significant improvement in weight, size, or performance is possible. Minor changes will be made, provided the new units are interchangeable with the old.
7. Adapters will be provided, so that radically new "standards" can be applied to existing equipment.
8. The units will be designed for new equipment primarily and not as replacement for existing equipment.

In brief, the unitization principle involves the design, production, and use of highly standardized unit functions, each designed for great reliability and replaceability. The actual reliability of each unit could be well established under all possible environmental conditions, so that the life of an assemblage of units could be predicted with considerable accuracy. In addition, the cost per unit for design, production, and maintenance could be assayed in advance.

Steps Toward Reliability. In a paper given before the National Airborne Electronics Conference /6/ Mirman makes the following suggestions to designers:

Each tube in a given existing radar involves five resistors and four capacitors, so that every tube involves ten component parts. The number of tubes in a system, therefore, can yield a figure of merit or provide a reliability index to the system, so far as the component parts are concerned.

Conservative design of tube circuits is highly desirable, instead of designing around the maximum tube rating. Greater consistency in performance will thereby be secured, since despite the batch-to-batch variation in tube manufacture such design will permit the tubes to be worked inside the maximum ratings and the probability of successful operation of the equipment is enhanced. Adequate safety factors for all components must be employed.

Built-in test equipment capable of describing on a relative basis the functioning of the elements of a system and of the system as a whole is highly desirable.

Elements and the components of elements should be so located that those most likely to need replacement are easiest to get at; in other words, the accessibility of parts should be proportional to their expected life.

The system reliability can be estimated by knowing the number and types and failure rates of the component parts, the time to locate and replace the individual parts, and the duty cycle of the equipment as a whole.

Reliability Program for Manufacturers. Individual manufacturers naturally differ in the way they are handling the reliability problem. In some

plants there is no individual responsible for reliability, and in others this responsibility is centralized. In one plant, widely known in this field, an administrator of reliability reports directly - and not through devious channels - to the chief engineer. In each of the numerous departments of a division producing military and industrial equipment there is a reliability representative. At regular intervals all of these representatives meet with the administrator, exchange information, and iron out difficulties. This manufacturer is comparing all of his equipment with the Rand and Vitro reports to determine if the reliability of his equipment is on the line, or better or worse. Where worse, studies immediately are made to determine the cause and to remedy it. Quick action is secured by the direct contact between the administrator and the chief engineer who is responsible for the entire operation.

Within a manufacturer's organization there should be clear and simple systems for collecting field reports, for determining what should be done with the data secured from the reports, and means for using the information in future design work.

A reliability program need not be restricted to manufacturers of complete units or systems. Such a program belongs in every laboratory designing equipment, in every place where the equipment is assembled, and in places where the final equipment is employed and serviced. Someone who coordinates all reliability information and activities is needed in each of these spots, where something can be done about the problem in a positive way.

Circuit Standardization. To make a simple electronic circuit do the same things as a complex circuit requires real engineering skill. It takes time and it costs money. But the overall price is probably lower, considering the maintenance cost as part of the complete picture.

A very great gain in simplicity can be made by standardizing certain types of circuits and equipments. In so doing, the time to repair equipment in the field can be decreased appreciably. A mere substitution of a good power supply for one that has failed is a great time saver. If the number of different kinds of power supplies and the voltages required can be reduced, much is to be gained by the simple fact that maintenance men need not be experienced for as many types of equipment. Even if the individual units cannot take the same physical shape, the same tube, transformer, and filter can easily be adapted to multitudinous applications.

In a study of test equipment for the Air Force, Frederick Research Corporation /7/ found that 474 items of frequency measuring equipment were available with government nomenclature. Of these, only 52 were essential to meet the needs of the Air Force.

On the matter of power supply, Muncy reports /8/ that a study of 13 radars disclosed that 21 different voltages were needed, although the great bulk of them could have been satisfied with five voltages.

He found that for virtually identical circuit functions in four radars, the number of resistors per cathode varied from 2.8 to 3.9 and the number of capacitors per cathode varied from 1.4 to 2.6. These differences represented the differences among the individual designers. He says, "All power supply circuits are directly and immediately standardizable in all equipments in which electronics supplies are used. These circuits may employ as high as 30 percent of the total cathodes."

Muncy's work in studying the diversity of circuits to perform identical functions has led to an interesting and useful compilation of "preferred circuits" described in more detail in Chapter 5. It is not difficult to come to the conclusion, as a result of reading the "Preferred Circuits Manuals," that a thorough investigation of a few circuits for a particular function would be very much more valuable than a cursory study of many circuits for this job.

Standard vs. Special Parts. Designers of military electronic equipment are often criticised for their apparent unwillingness to use standard component parts, that is, parts that are in wide and high production, parts that have been in production long enough for the bugs to be ironed out, for the characteristics to be well known, and to conform to JAN specifications.

It must be remembered that mass production items by companies with good reputations have histories that are well known because life tests have been completed, and they are likely to be in production at the time there is need for them in large quantities. It must also be remembered that companies of this class cannot afford to produce poor products or to re-lease such products for large-scale use.

On the other hand, special parts are often necessary and waivers for their use must be secured. If a component part is selected because it is proven to be more reliable by test, even though it may not yet be certified by appropriate agencies, then the onus is removed from the design engineer for selecting that component part.

A piece of equipment made of nonstandard parts to any great degree is certain to have some suspicion directed to it and to its designer and manufacturer.

It is realized that much time is required to secure JAN authorizations for new component parts for, by their very nature, these specifications are cautiously made and always somewhat behind the state of the art. The feeling of security on employing JAN parts, however, over the use of nonstandard and perhaps special parts, is very real.

The JAN specifications are under constant review.

In general, it seems that better products will be secured if a large run is possible. During the run the process becomes stabilized, good "teamwork" is attained, and experience is accumulated. If a later

run is necessary, all the variables must be ironed out anew.

Quality control of component parts entering an assembler's plant is of vital importance to any reliability program; more and more manufacturers seem to be arriving at the total-inspection point instead of relying on sampling procedures.

The important connection between reliability and the special parts problem can be evaluated from a single report on the Ad Hoc Group findings by Given. /9/

Special component parts (those that were not standard and which were probably produced in small quantities) accounted for 70 percent of the replacements, whereas standardized high-production types accounted for only 30 percent. Special connectors, which amounted to only 24 percent of the connector population, accounted for 75 percent of the connector troubles; special capacitors amounted to only 2 percent of the population but accounted for 50 percent of the replacements; special relays accounting for only 5 percent of the relay population caused 85 percent of the troubles.

#### FIELD FAILURE REPORTS

Each of the Services has had in operation for some time methods for reporting failures from equipment in the field. Vast quantities of information on individual units, component parts, and equipments have been amassed and has a considerable value in showing tendencies for failure. Some attempts are being made to develop uniform systems of reporting that produce data which can be handled statistically.

The Objectives of Field Failure Data Reporting, which follow, are from a Wright Air Development Center memorandum of 11 January 1954.

Purpose. The purpose of field failure reporting is to obtain good quantitative data on failures suitable for statistical analysis and processing by machine methods, and to provide a sound scientific basis for reliability improvement of ... weapons systems including design improvement, maintenance and supply activities, and operational and management planning.

Information Required. The basic (field) information desired, designed to be valid statistically is:

1. Number of failures, including preventive maintenance replacements.
2. Identity of failed component, including reporting organization, major system and subsystem, failed part and manufacturer.
3. Cause of failure, if known, and including type of failure.
4. Time-to-failure; total elapsed time in operation before failure.

5. Conditions under which failure occurred, including items necessary to evaluate maintenance, to evaluate effect of failure on operations, and to guide statistical analysis of data designed to pinpoint basic cause of failure.

Information from Failure Reports. Through analysis of a sufficient body of failure reports, the following information may be ascertained.

1. How well the equipment meets reliability requirements.
2. The important causes of failure.
3. Recommended changes in design, production, or use of the equipment.
4. Effect of changes on reliability of equipment and systems.
5. Necessary modifications to reliability requirements.

Such information can lead to answers to various important questions, such as:

Is the equipment good enough from the standpoint of reliability?

If not, what should be done about it?

Are present concepts of "good enough" realistic or unreasonable? Possible, or hopelessly out of range? Should the criteria for "good enough" be revised upwards or downwards?

Data Usage. Once the data have been collected in sufficient quantity to learn the picture of the particular equipment, systems, or component parts involved, several organizations can begin to extract important facts for their own usage. For example:

1. Operations: Determine the number of equipments required to accomplish a given mission, that is, to make a reliability prediction.
2. Maintenance: Determine manpower requirements, establish preventive maintenance schedules, and detect serious trouble areas.
3. Logistics: Determine accurate parts consumption data and spare unit requirements.
4. Engineering: Perform reliability evaluation, prediction, design improvement, and, in conjunction with operational agencies, establish reliability requirements.

Engineering Reports. The memorandum /10/ cited points out that the field reports giving

data on failures should be in such a form that the data can be processed by machinery, and it also points out that other, less terse, reports of an engineering nature are also necessary. The so-called "UR's" (Unsatisfactory Reports) are less objective than those desired for statistical purposes, and should be prepared when a detailed summation of conditions is desirable; when deficiencies should be processed, properly, through channels; when formal corrective action is requested; and when deficiencies must be reported that do not show up as failures - the inaccessibility of items for maintenance, for example.

The memorandum does not recommend that the two types of field reports be combined into one, because each gives data that the other cannot.

It is obvious, of course, that the mere collecting of great quantities of information is not useful by itself, that the reports must be in such a form that action can be taken quickly and usefully, and that files full of data are worthless unless something is done about them.

Every attempt must be made to relate the failure of a tube or other component part to the cause of failure. To know that many thousands of 6A6 tubes have to be replaced in a system is not of much value to designers of future equipment unless a study is made to find out why these tubes fail. This means that information from the field must be fed back into the intellectual system that produced the equipment and that is responsible for future design. In this particular situation, it is known that the 6A6 tube was employed very widely in circuits for which it was not adapted - balanced d-c amplifiers - and that proper consultation with application engineers in the tube manufacturing plants would have disclosed the probability of trouble from this cause.

To gather the failure data is essential, to see that it means something is even more necessary, and to ensure that designers of future equipment know what caused the failures should be a requirement.

Failure Prediction. Having collected sufficient data from the field, and having tabulated the causes of failure and the conditions under which the component parts or the device failed, information should be available from which mortality tables can be prepared showing the probable replacement rate for each component part. Such information would be useful to designers of new equipment, as well as to those responsible for seeing that the replacement shelves and the pipe line are not lacking in essentials.

From such data it would be possible to determine the rate at which individual component parts must be replaced and the time to locate the trouble spots and get the equipment in working condition again. At this point the overall reliability of the equipment or system would be known.

The data so obtained would be very useful to component parts engineers and manufacturers, who cannot possibly determine reliability data for every

component part under all the various conditions of use. And yet this data, vitally needed if the design engineer is to affix a normal reliability dimension to his equipment, is largely unobtainable to date.

Several studies are under way to determine in advance of field trials the probability of reliability, that is, to predict the chance of failure./11/ Such studies should be very productive and, when added to the information now being collected on failure rates in all kinds of electronic equipment, should supply the designer with an exceedingly useful background.

Summary. From the systems standpoint, then, design starts at both ends of the design process — from the top or systems aspect and from the

bottom, or component parts and subassembly aspect. As more is learned about the requirements of the system and the capabilities of the parts, and as both types of information are exchanged throughout the long chain from designer to manufacturer to operator to maintenance personnel, we will have effective, efficient, long-lived systems of weapons, communications, or defense warning.

There can be no doubt that a working and workable system of past vintage is better than a new system, with all the new concepts and possibilities, that work only part of the time. There can never be any assurance that it will work at the exact time needed and in the exact manner desired — which is our definition of reliability.

## REFERENCES

1. Price, D. K., Government and Science, New York University Press, 1954.
2. Elmendorf, C. H., "Component Engineering as a Part of System Design," Proceedings of the 1954 Electronic Components Symposium, p. 8.
3. Oldfield, H. R., Jr., "Role of Research and Development in Aviation Electronics," National Conference on Airborne Electronics, Dayton, Ohio, May 1954.
4. Taylor, Dennis, "The Reliability of Nucleonics Instruments," paper presented 9 July 1954, Industrial Electronics Convention, Oxford, England and to be published in the Journal of the British Institution of Radio Engineers.
5. Brush, J. W., (Bureau of Ships), "Achievement of Reliability by the Use of Functional Subassemblies as Standard Building Blocks," Proceedings of the 1954 Electronic Components Symposium, p. 203.
6. Mirman, I., "Reliability of Electronic Equipment," National Airborne Electronics Conference, Dayton, Ohio, 12 May 1952.
7. Frederick, C. L., and E. E. Blanche, "Evaluation of Electronic Test Equipment," National Airborne Electronics Conference, Dayton, Ohio, May 1952.
8. Muncy, J. H., Feasibility Study of Electronic Circuit Standardization Equipment Analysis, National Bureau of Standards Report 2919.
9. Given, F. J., Reliability in Electronic Equipment, Guided Missile Committee of Aircraft Industries Associated, White Sands Proving Ground, 20 April 1954.
10. Objectives of Field Failure Data Reporting, Wright Air Development Center (WCSPD), January 11, 1954.
11. Electronic Equipment Reliability Program, Vitro Corporation of America, Contract NObsr 63389.

# CONTENTS

## chapter four

### **mathematical approach to reliability**

The Mathematical Approach to Reliability

Prerequisites for a Statistical Approach to Reliability

Quantitative Definitions

Probability Relations and Concepts

Continuous Probability; Failure Rate, Reliability, and Hazard

Series Reliability

And/or Probability; "Parallel" Reliability

The Exponential Law of Reliability

The Gaussian Law; "Wear-out" Failures

Sources of Reliability Data

Qualitative Use of Reliability Theory

# MATHEMATICAL APPROACH TO RELIABILITY

## THE MATHEMATICAL APPROACH TO RELIABILITY

Like gain, sensitivity, and power output, reliability of electronic equipment is a performance characteristic. Like other performance characteristics, reliability can be defined explicitly and expressed numerically.

The nature of reliability, however, is such that its quantitative treatment poses a number of special problems.

In the first place, there is no accepted quantitative definition of reliability. The power output of a radio transmitter, for example, is expressed in watts, and can be measured by methods that are widely understood and accepted. Not so reliability. Reliability is widely understood only as a qualitative expression of ability to "take it."

Secondly, reliability of electronic equipment is affected by a great many more variables than are most performance characteristics. Whereas the gain of an amplifier is primarily determined by a relatively small number of component parts, equipment reliability is a function of substantially every component part, mechanical as well as electrical. This means that calculation of reliability in a manner similar to the calculation of amplifier gain is much more complex, because of the necessity of accounting for the effects of a great many more components.

Thirdly, experimental determination of reliability is much more difficult than measurement of most performance characteristics. Many factors that influence reliability, such as handling during shipment, maintenance procedures, and operating environment cannot be simulated accurately under laboratory conditions. Reliability testing, whether under field or laboratory conditions, requires the amassing of a great amount of data. Equipment must be tested to its reliability limit, and a large number of such tests must be made to arrive at any accurate result expressing the reliability of the equipment type. Also, reliability

testing tends to be destructive by nature, so that an equipment, once tested, may be of little or no value for subsequent service. Thus reliability testing is expensive, time-consuming, and destructive.

The existence of such problems is probably responsible in large part for the past lack of serious attention to electronic equipment reliability. However, the reliability problem has not proved to be one that, if ignored, will eventually disappear. To the contrary, the problem grows more severe with the passage of time. Thus, it is necessary to find some means of dealing with the obstacles to its quantitative treatment, means of putting the reliability problem on a practical mathematical basis.

One needs to be associated with the reliability problem for only a short time to realize that it is basically a statistical problem.

The mathematics of probability and statistics offer an excellent means for treating such a problem as reliability. Provided only that a suitable quantitative definition can be arrived at, probability techniques afford an approach to the treatment of the interrelations among the great many variables present in reliability problems. Similarly, statistical methods offer the opportunity to derive a maximum of useful information from a minimum of data.

Statistical methods, however, have limitations that must be recognized. It is impossible to say with certainty whether a particular equipment will operate satisfactorily for a given period of time, or for how long it will operate how well. The best that can be done is to say what is likely to happen, and how likely it is. There is no such thing as an absolute guarantee of electronic equipment reliability, and any such guarantee that may be expressed is as much an indication of willingness to gamble as it is of the reliability of the equipment.

Like any other form of mathematics, probability and statistical methods are aids to logical

reasoning, rather than substitutes. A blind statistical approach, without regard for the dictates of common sense, is particularly fruitful in its possibilities for arriving at incorrect conclusions on the basis of apparently valid methods of treating seemingly legitimate data. As with any branch of mathematics, the validity of a statistical result is no better than the input data and the manner in which it is used.

In statistical treatment of reliability, the most serious sources of possible error include:

1. Inaccurate data obtained through careless experimental methods or from questionable sources.
2. Use of otherwise valid data under circumstances to which the data do not apply.
3. Basing a firm conclusion on a quantity of data so small as to have little or no statistical significance.
4. Incorrect interpretation of data.

The possibilities for error, however, should not be a deterrent to the use of statistical methods. Few errors will go undiscovered in the face of a critical, commonsense attitude. In this connection, Huff's recent book offers a readable, nonmathematical discussion of misleading statistics and how to detect them./1/

#### PREREQUISITES FOR A STATISTICAL APPROACH TO RELIABILITY

Prerequisites for a probability/statistical approach to reliability problems include:

1. An understanding of the practical significance of the mathematics of probability and statistics.
2. A quantitative concept of reliability, in appropriate form for treatment by probability methods.
3. Raw data applicable to the reliability problem at hand.
4. The proper probability and statistical tools for relating the raw data to the total problem.
5. Common sense in applying the mathematical results to practical problems.

Each of these prerequisites will be treated in some detail in subsequent sections of this Chapter.

#### QUANTITATIVE DEFINITIONS OF RELIABILITY

There are a great many possible definitions of reliability, some of which are quantitative, others merely qualitative. In arriving at a definition to be made the basis of numerical expression of reliability,

one might first ask why numerical measurement is necessary. Why must reliability be assigned numerical values? Why is it not sufficient merely to say that one component or equipment is more or less reliable than another, and to strive constantly for improvement?

Need for Quantitative Definition. Numerical expression of reliability is important primarily as a basis for decisions. The operations analyst must decide what degree of equipment reliability is required to ensure desired performance in a system consisting of several equipments. The engineer who prepares the equipment specifications must decide on reliability requirements compatible with both the state of the art and operational needs. Logistics personnel need a basis for evaluating replacement requirements from information on equipment life. The equipment design engineer must make design decisions that will attain the required value of reliability. Maintenance officers must have a measure of equipment reliability as a basis for maintenance personnel assignments. Finally, the field commander with operational responsibility needs a basis for relating the overall capability of equipment and equipment systems to the requirements of operational situations.

Stated simply, a quantitative definition of reliability should be meaningful to all personnel in terms of their respective responsibilities, and should provide them with an adequate basis for making necessary decisions involving equipment reliability.

Definition Requirements. To meet these requirements, a quantitative definition of reliability should possess the following characteristics:

1. It should be simple enough to be made the basis of mathematical calculation.
2. It should be broad enough to include the effects of all significant contributions to reliability (or its reverse, unreliability).
3. It should be expressed in such manner as to permit application of reliability data that is already available or that could be obtained with reasonable effort
4. It should be expressed in terms that are meaningful to all persons and activities concerned with electronic equipment reliability.

A comprehensive definition of reliability, one that "gets to the root of the problem," might be based in some manner on the operational consequences of equipment or system failure. While expressing the reliability problem on its fundamental basis, such a definition would be of little practical value, covering more ground than could be properly examined at any single step in the process of assuring and maintaining reliability. To be of real practical value, a definition of reliability must be somewhat more limited, and in fact several definitions may be necessary to satisfy the requirements of all areas of the reliability problem.



In view of the statistical nature of the problem, the most appropriate definitions will be those having a probability or statistical basis. A basic definition may be established, and this basic definition can then be developed into more specific forms to meet the requirements of various areas of the reliability problem.

The Basic Quantitative Definition of Reliability. Reliability is defined as the "probability that a component part, equipment, or system will satisfactorily perform its intended function under given circumstances."

The "circumstances" referred to may be environmental conditions, such as temperature and vibration, or limitations as to operating time or frequency and thoroughness of maintenance.

Note that this definition includes the criterion "satisfactory performance." The implication is that there is some value of performance (for example, radar range) that represents the boundary between performance that is considered "satisfactory" and performance that is considered "unsatisfactory." Since the principle that "half a loaf is better than none" frequently applies to electronic equipment, the classification of performance as being either satisfactory or unsatisfactory is somewhat of an oversimplification. However, it is a practice that is commonly followed in electronic equipment specifications, and the problem is complicated excessively by any attempts to express further the relative merits of varying degrees of performance. The basic quantitative definition of reliability, then, applies only to cases in which the equipment can be considered as totally operative or totally inoperative.

Reliability Defined as a Function of Time. If the criterion of "satisfactory performance" in the basic definition is taken to include a minimum acceptable operating time  $t_1$ , and if the "given circumstances" include an attempted operating time  $t_2$ , the basic definition may then be restated:

Reliability is the probability that a component part, equipment, or system will operate satisfactorily for a period of time  $t_1$  when the attempted period of operation is  $t_2$ .

According to this modified definition, the numerical value of the reliability depends on the values of  $t_1$  and  $t_2$ .

In the special case where  $t_1$  equals  $t_2$ , the definition is appropriate for evaluating the reliability of equipment that is required to complete a mission of given length without failure. For example, the definition may be used to evaluate the reliability of equipment for use in aircraft or guided missiles when the length of a single mission is known.

In the more general case when the minimum acceptable operating time  $t_1$  is less than attempted operating time  $t_2$ , the modified basic definition is suitable for evaluating the reliability of equipment

intended for essentially continuous duty over long periods of time. An example of such equipment is an early warning radar, whose task is one of "watchful waiting." Failure of the radar at one particular time is not predictably more serious than failure at any other time, and some small fraction of the total elapsed time is normally allowed as "down time" to permit maintenance of the equipment. For such cases, reliability may be evaluated for large values of  $t_2$  and various values of the ratio  $\frac{t_1}{t_2}$ .

A similar approach is taken by many specifications for equipment intended for essentially continuous duty. The specification may require that the equipment be operable for at least 23 hours out of every 24. Stated in this manner, however, the requirement lacks a statistical basis. It requires the unrealistic guarantee that each equipment must operate satisfactorily for at least 23 hours out of each 24 hour period. A more realistic statement of the requirement, and one that would be essentially the same in effect, would be that the average ratio of successful operating time to total elapsed time must be at least  $\frac{23}{24}$  over a long period of elapsed time. Since perfection represents a ratio of only  $\frac{24}{24}$ , restatement of the requirement as an average ratio would result in negligible reduction in the minimum allowable reliability.

Other Definitions. In addition to the basic and modified definitions discussed above, certain other measures of reliability can be applied usefully, with relative ease, to particular areas of the reliability problem.

For scheduling maintenance personnel, it may be useful to adopt a limited definition of reliability as the average number of hours of maintenance required to obtain one hour of satisfactory operation.

Scheduling of equipment replacements can be facilitated by a measure of "equipment mean life," that is, the average total operating time, storage life, and so on, of an equipment before it becomes unfit for further service and must be replaced.

"Average success rate reliability" may be defined as that fraction of the total number of equipments in use which operate satisfactorily for a given period of time. Similarly, reliability can be measured in terms of the total number of failures encountered in a stated number of equipments during a given time. Such measures of reliability are considerably less informative than those based on the definitions first discussed, but are potentially useful because of the relative ease with which data can be obtained.

Finally, reliability may be defined as a function of the ratio of actual performance to ideal performance. Two features of this definition make it especially interesting. First, such a definition can be used, with suitable interpretation of terminology, to evaluate the effects on reliability of specific conditions, such as severe environment. The ratio of actual field performance to "ideal" laboratory performance would be a measure of the adverse effect

of field environment on equipment performance reliability. Similarly, it is possible to determine the degree to which equipment is critical as to the skill of the operator, by comparing how equipment performs in the hands of a well-trained operator with performance when it is operated by personnel of only average capabilities.

Second, use of the ratio of actual performance to ideal performance is a means of taking account of performance variations that are not sufficient to cause the equipment to be regarded as having "failed." Thus, reliability expressed as a function of a performance ratio avoids the oversimplification of considering performance as either "good" or "bad."

The mathematical techniques presented in the following sections relate primarily to the first two definitions of reliability, those based on probability of satisfactory performance. However, these mathematical techniques are also useful, and in many cases necessary, in evaluating reliability according to the more specialized definitions.

### PROBABILITY RELATIONS AND CONCEPTS

Probability. Thus far in this Chapter, the term "probability" has been used in connection with electronic equipment reliability, but has not been defined. Although the meaning of "probability" is generally understood, at least in the vague sense that it is a measure of "likelihood," a more precise definition is in order as a prelude to detailed consideration of the mathematical aspects of reliability.

If the total number of ways in which an event can occur or fail to occur can be analyzed as "a" successes and "b" failures, each equally likely, the probability of occurrence of the event in a single

trial is  $p = \frac{a}{a + b}$  and the probability of failure is

$$q = \frac{b}{a + b}$$

Thus it is seen, first, that probability is defined in terms of a set of exhaustive, mutually exclusive possibilities,  $a + b$  in number. All possibilities for occurrence and nonoccurrence of the event are included in  $a + b$ , and materialization of one of the  $a + b$  possibilities in a given trial excludes all others. Second, it is seen that probability is represented by a number between 0 and 1. The upper limit, unity, represents certainty; the lower limit, zero, denotes impossibility.

In the simple case in which a die is tossed once, the definition of probability may be readily applied to discover that the probability of tossing a "5" is  $1/6$ . Similarly, the probability of tossing a number that is evenly divisible by three is  $2/6 = 1/3$ .

To illustrate the definition of probability as applied to the reliability of electronic equipment, consider the following case. It is desired to determine the 100-hour reliability of a certain type radar under certain operating conditions, that is, the probability

that the radar will operate satisfactorily for a period of 100 hours. Previous experience with 10 radars whose design was identical to the one in question showed that 8 were operating satisfactorily after 100 hours, the remaining 2 having failed. We immediately conclude that the probability, or reliability, is 0.8, or 80 percent.

In relation to the definition of probability, the argument is as follows. Since the radar with which we are concerned is identical in design and operating conditions to the 10 previously tested, it can be expected to follow the behavior of 1 of these 10. Further, the chance of its behaving as did a particular 1 of the 10 is equal to the chance of behaving like each of the others. Thus, there are 8 opportunities for successful completion of 100 hours operation, as against 2 opportunities for failure. The probability of

$$\text{success is then } \frac{a}{a + b} = \frac{8}{10}$$

This example also illustrates the statistical nature of the reliability problem; data from past experience has been used to estimate the probability of a future event. In fact, most reliability problems depend on experimental data for their solution. In the simple case of tossing a die, we do not feel the need of experimental evidence to conclude that the six faces of the die are equally likely to be uppermost (unless we suspect the die may be "loaded"). Electronic equipment reliability, however, is not such a simple problem, and experimental evidence of some sort is usually required to arrive at any reasonably accurate numerical predictions.

In this connection, one might well question the accuracy of our conclusion that the 100-hour reliability of the radar in question is 80 percent. Granting that the design and operating conditions are identical for all the radars, there are still two very pertinent objections to our method of estimating the reliability of the radar.

In the first place, a scale of reliability measurement based on only 10 radars is too coarse. Since the number of radars tested was such that the only possible results were 0, 10, and 20 percent, and so on, up to 100 percent, the second digit of our 80 percent reliability figure is not significant. The best we can say is that the reliability is somewhere between 75 and 85 percent. Although this may not be a serious objection in the region of 80 percent reliability, it would be serious if the test had shown 9 or even 10 of the radars still operating satisfactorily after 100 hours.

In the second place, is 10 radars a sufficient number on which to base a conclusion? That is, is a quantity of 10 samples statistically significant in the case in question? The answer depends on a number of factors, including the accuracy with which we need to know the reliability and the extent to which the reliability differs in different radars of identical design. In all likelihood, however, 10 radars is not a sufficient number for an accurate conclusion.

Both these objections could be overcome by accurate, detailed data on failure rate vs. time for

the radars in question. From such data, it would be possible to plot a continuous curve of failure rate, and from such a curve the reliability corresponding to any desired operating time could be accurately determined.

Continuous Probability; Failure Rate, Reliability, and Hazard. Not all probability problems are concerned with discrete variables, such as the number of spots on the face of a die. Instead, a large proportion of cases deals with variables that are continuous, at least between limits. Although it may sometimes be necessary to base predictions on a finite amount of experimental data in such cases, serious errors can result from use of an amount of data so small that it does not permit a satisfactory approximation of the actual continuous curve. This is the case if we attempt to estimate radar reliability according to the method used in the previous example.

One can conceive of a large number of units, if not complete radars at least radar components, tested to failure, with an accurate record kept of the operating time at which each failed. From the data thus obtained, it would be possible to plot a curve of hourly failure rate vs. elapsed operating time, the precision of this curve depending on the total number of components tested. In a typical case, the curve so obtained might have a shape similar to that shown in Figure 4-1.

It is apparent, by reasoning similar to that previously employed to relate radar reliability to the classical definition of probability, that a curve of failure rate of a large number of similar components is directly related to the probability of failure of one of the components selected at random. In fact, if the ordinate scale is adjusted so that the total area under the curve is unity, then the probability that a component selected at random will fail during a particular hour is given by the ordinate value corresponding to the operating hour in question.

More significant in the practical case, the integral of the failure rate curve between any two

abscissa values is the total probability of failure of a randomly chosen component during the corresponding interval of operating time. The ordinate scale, of course, must be such that the integral from zero to infinity equals unity.

If we had a curve such as Figure 4-1 to represent the failure rate of the radars considered in the previous example, the 100-hour reliability of one of the radars could be determined, first, by integrating the curve from 0 to 100 hours to find the probability of failure during this period and, second, by subtracting the probability of failure from unity to find the probability of success, that is, the reliability. Alternatively, the integral of the curve from 100 hours to infinity gives the reliability directly.

Figure 4-2 is a plot of the integral of the failure-rate curve of Figure 4-1 between various lower limits and an upper limit of infinity. Thus, Figure 4-2 is the reliability curve corresponding to the failure-rate curve of Figure 4-1.

Failure-rate data such as used to plot Figure 4-1 is also capable of yielding information on the "hazard," which is the fraction of "surviving" components failing per hour. Figure 4-3 is a plot of the hazard corresponding to the failure rate data of Figure 4-1. Whereas Figure 4-1 shows the probability of failure of a particular component based on the total number of components at the beginning of the test, Figure 4-3 represents the probability of failure at various future times of the surviving components at a particular time. Data such as Figure 4-1 would be of primary interest in considering the probable life of a new component or equipment; Figure 4-3 gives information to answer such questions as, "What is the probability that an equipment (or component) that has survived 100 hours of operation will survive an additional 50 hours?"

Table 4-1 shows the data from which Figures 4-1, 4-2, and 4-3 were obtained. Table 4-1 gives operating time  $t$ , cumulative number of failures  $F$ ,

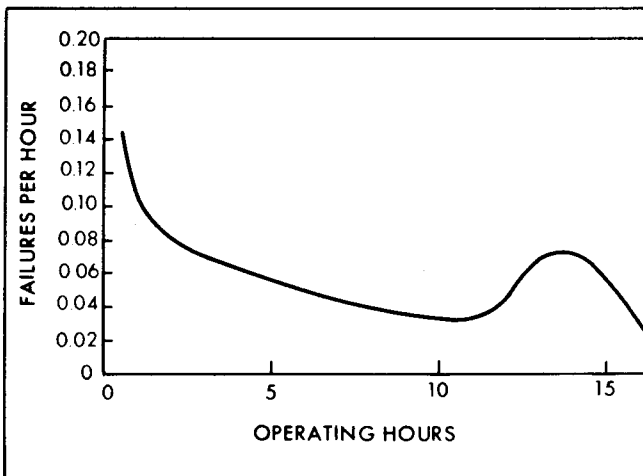

Figure 4-1. Typical failure rate curve

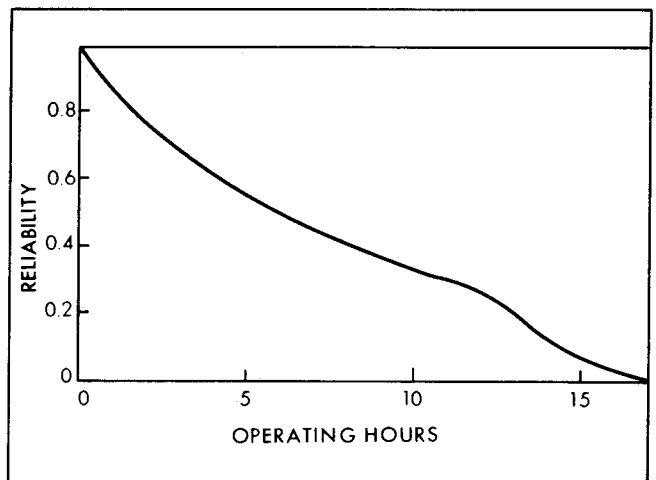

Figure 4-2. Typical reliability curve (Corresponding to failure rate curve of Figure 4-1)

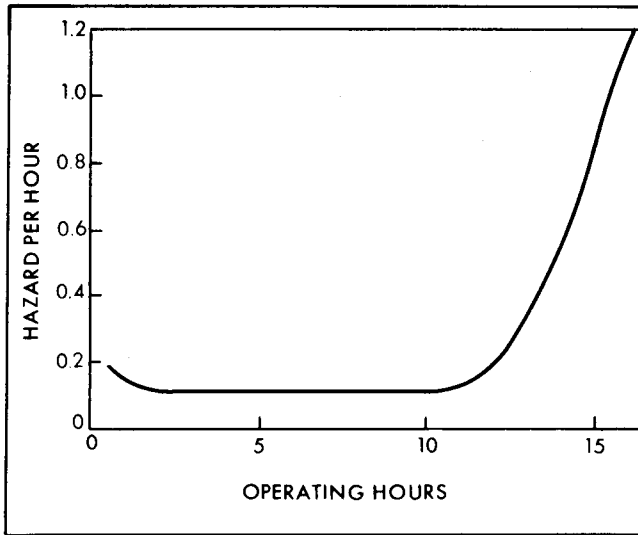

Figure 4-3. Typical hazard curve (corresponding to failure rate curve of Figure 4-1)

number of survivors  $S$ , failure rate  $Y$ , reliability  $R$ , and hazard  $Z$ . If  $N$  is the number of components at the start of the test,

$$S = N - F \quad (1)$$

Reliability is obtained directly from the fraction of initial components surviving at the end of each hour,

$$R = \frac{S}{N} \quad (2)$$

Failure rate, the rate of decrease in the reliability, can then be determined from the reliability as

$$Y = \frac{dR}{dt} = \frac{1}{N} \frac{dF}{dt} \quad (3)$$

The hazard is the ratio of the number of failures per hour to the number of survivors at that time, or

$$Z = \frac{1}{S} \frac{dF}{dt} = \frac{1}{R} \frac{dR}{dt} \quad (4)$$

Integrating this equation gives an important relation between the reliability and the hazard,

$$R = e^{-\int_0^t Z dt} \quad (5)$$

The relation among reliability, failure rate, and hazard is

$$Y = RZ \quad (6)$$

On the basis of data presently available, a curve of the general shape of Figure 4-1 may be considered typical of the failure rate of electronic component parts and equipment. The curve is characterized by an early period of high failure rate, during which the "weak" individuals among the component

part population fail, an intermediate region of lower failure rate, and finally a region in which "wear-out" failures produce an increase in the failure rate until it drops to zero as the last survivors fail.

Figure 4-1 does not show the influence of the initially defective component parts, which are inoperative at the outset,  $t = 0$ . The number of initial failures depends on factors such as the care with which the equipment was originally manufactured and inspected, the treatment it received between point of manufacture and point of installation, and the care with which the equipment was tested after being installed but before being placed in service.

**Joint Probability of Independent Events.** It has been shown that reliability can be determined as the integral, between appropriate limits, of a curve of failure rate. In view of the large number of different equipments with whose reliability we may be concerned, it is impossible from the standpoint of both time and expense to collect failure rate data by life-testing a large number of equipments of each type under each set of operating conditions that may influence the equipment failure rate. It is considerably less difficult, however, to collect failure rate data on the individual component parts that make up electronic equipment. Since a relatively small number of types of component parts accounts for a high percentage of the total number of component parts in any electronic equipment, component part failure rate data, once collected, is widely useful. Equipment failure rate data obtained by life-testing a large number of equipments of given type, on the other hand, is of little or no use in judging the reliability of equipment of some other type. In fact, such data can be rendered essentially useless, even for the equipment from which it was originally obtained, by a relatively minor change in equipment design.

It is essential, therefore, to be able to relate reliability data on component parts and subassemblies to the reliability of complete equipments and systems. The theory of probability affords the means of establishing such relations.

If the probabilities of occurrence of two independent events  $A$  and  $B$  are respectively  $P_A$  and  $P_B$ , the probability of simultaneous occurrence of the two events is the product of their individual probabilities, or  $(P_A)(P_B)$ . Thus, the probability of throwing a double six on one toss of a pair of dice is  $\frac{1}{6} \times \frac{1}{6} = \frac{1}{36}$ . Similarly, if the 100-hour reliabilities of two electronic component parts under given conditions are respectively 0.9 and 0.8, and if failure or nonfailure of one has no effect on the other, then the reliability of a subassembly consisting of the two component parts is  $(0.9)(0.8) = 0.72$ .

In applying this principle, it must be borne in mind that the individual probabilities (reliabilities) must be independent for the principle to be valid. Unfortunately, this condition does not always hold in electronic equipment, because of such factors as common sources of similar component parts and functional interdependence of parts in the equipment.

Table 4-1. Typical failure data /2/

Operating time in hours	Cumulative number of failures	Number of survivors	Failures per hour per component at start of test	Reliability	Hazard (failures per hour per surviving component)
t	F	S	Y	R	Z
0	0	1000		1.000	
1	145	855	0.145	0.855	0.156
2	231	769	0.086	0.769	0.106
3	308	692	0.077	0.692	0.105
4	377	623	0.069	0.623	0.105
5	439	561	0.062	0.561	0.105
6	495	505	0.056	0.505	0.105
7	546	454	0.051	0.454	0.106
8	591	409	0.045	0.409	0.104
9	632	368	0.041	0.368	0.105
10	669	331	0.037	0.331	0.106
11	702	298	0.033	0.298	0.105
12	737	263	0.035	0.263	0.125
13	797	203	0.060	0.203	0.256
14	872	128	0.075	0.128	0.453
15	937	63	0.065	0.063	0.680
16	979	21	0.042	0.021	1.000
17	995	5	0.016	0.005	1.231

**Series Reliability.** The theory of joint probabilities applies to the reliability of electronic equipment in which the components are functionally in series, that is, in which failure of any part will fail the equipment. The series case is by far the most prevalent in electronic equipment.

The theory of joint probabilities can be extended to any number of component parts in series. Thus, if a radar consists of  $n$  component parts whose 100-hour reliabilities are respectively  $R_1, R_2, R_3, \dots, R_n$ , then the 100-hour reliability of the complete radar is

$$R_e = (R_1) (R_2) (R_3) \dots (R_n) \quad (7)$$

It is apparent that an equipment consisting of several hundred, or several thousand, series component parts places very severe demands on the reliability of the individual component parts if reasonable equipment reliability is to be achieved.

In the special case of  $n$  series component parts whose reliabilities are equal, the equipment reliability is the component part reliability raised to the power of the number of parts,

$$R_e = R_c^n \quad (8)$$

Figure 4-4 is a plot of the reliability of equipment consisting of various numbers of series component parts of equal reliability. Equipment reliability is plotted as a function of the number of components, with component reliability as a parameter.

Equation (8) and Figure 4-4 also apply to equipment in which the part reliabilities are not equal if the value used for part reliability,  $R_c$ , is the geometric mean of the various part reliabilities, that is,

$$R_c = \sqrt[n]{(R_1) (R_2) (R_3) \dots (R_n)} \quad (9)$$

If the reliabilities of the various component parts fall into groups in which the reliability of all parts in the same group is approximately equal, then equipment reliability may be expressed according to another special form of Equation (9)

$$R_e = (R_1^{n_1}) (R_2^{n_2}) (R_3^{n_3}) \dots \text{etc.} \quad (10)$$

where  $R_1$  is the reliability of each component part in group 1 and  $n_1$  is the number of parts in the group, and so on.

Depending on the viewpoint one wishes to take, Equations (7) through (10) and Figure 4-4 emphasize the increasing importance of component part reliability as equipment complexity increases or, alternatively, the disadvantages of increased equipment complexity with components of fixed reliability.

As an example of the use of Equation (7) and its special forms in solving reliability problems, assume an equipment containing 100 tubes and a total of 1,000 other parts. Assume that available data

indicate a 100-hour tube reliability of 0.93 and a geometric mean reliability of all other parts of 0.98 at 100 hours operation. Then the equipment reliability is

$$R_e = (0.93^{100}) (0.98^{1000}) = 0.0007047 (0.00000001698) \\ = 1.2 \times 10^{-12}$$

It is interesting to make a comparison with an equipment only one-tenth as complex, that is, containing 10 tubes and 100 other parts. The reliability at 100 hours is then

$$R_e = (0.93^{10}) (0.98^{100}) = (0.484) (0.133) = 0.0645$$

The reliability is still very poor, but it is certainly a marked improvement over the more complex equipment.

**And/or Probability; "Parallel" Reliability.** In many instances, the importance of reliability is such that critical components in an equipment, or even complete equipments combined in a system, are duplicated in such a manner that if one of the components or equipments fails, its function can be assumed by another. With such functional paralleling of parts, failure of all the paralleled parts is required to fail the equipment or system.

In determining the reliability under such conditions, one asks, "What is the probability that at least one of the duplicate components or equipments will still be operating satisfactorily after a given time?" In this case, we are dealing with what might be termed "and/or" probabilities, the probability that either or both of two components, for example, will survive the desired operating interval.

In the case of two components whose reliabilities are respectively  $R_A$  and  $R_B$ , the probability that at least one will survive, that is, the reliability of a parallel combination of the two, is the sum of the probabilities of the three possible favorable outcomes.

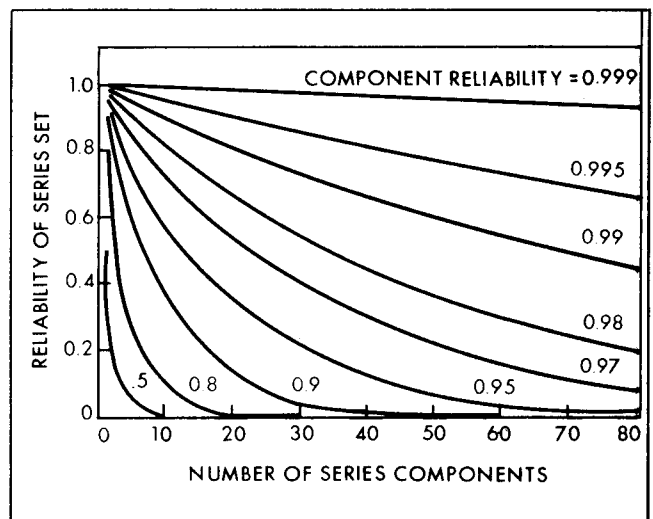

Figure 4-4. Reliability of " $n$ " series components of equal reliability

These three outcomes are failure of neither A nor B, failure of A but not B, and failure of B but not A.

$$R_{A,B} = R_A R_B + R_B (1 - R_A) + R_A (1 - R_B) \quad (11)$$

For example, if  $R_A = R_B = 0.9$ , then the reliability of A and B in a parallel arrangement is  $(0.9)(0.9) + (0.9)(0.1) + (0.9)(0.1) = 0.99$ . Thus, the use of a standby component has achieved a significant increase in the reliability that would exist with either A or B alone.

The same result, of course, can be arrived at by considering the probability of the one possible unfavorable outcome in the case in question, namely failure of both A and B, and subtracting this probability from one. The probability of failure of both A and B is the product of their individual failure probabilities, namely, 0.1 each, and the reliability of a parallel combination of A and B is thus

$$R_{A,B} = 1 - (1 - R_A)(1 - R_B) = 0.99 \quad (12)$$

as previously calculated.

Figure 4-5 shows the increase in reliability resulting from functional paralleling of various numbers of components of equal reliability.

**The Exponential Law of Reliability.** The statistical reliability data that has been collected to date suggests another important form of reliability equation, referred to as the "exponential law of reliability." A number of field failure studies have found that component part failures tend to occur randomly in time. That is, the failure rate of the parts in service at a particular time tends to have a constant value; the hazard is constant, independent of operating time. The possibility of such a condition is suggested by the central portion of the hazard curve of Figure 4-3, providing that the failures during the "infant" and "old age" periods are a small proportion of the total number of component parts. From Equation (5), if the hazard has a constant value,  $r$ , reliability becomes

$$R = e^{-rt} \quad (13)$$

This is the basic form of the exponential law of reliability.

For practical application, a more useful form of the exponential law is

$$R = e^{-t/T} \quad (14)$$

where  $T = 1/r$  is the reciprocal of the constant hazard,  $r$ , and is the mean time to failure. Thus, for the conditions under which the exponential law holds, reliability can be expressed solely in terms of the ratio of the operating time of interest to the mean time to failure. Figure 4-6 plots reliability according to the exponential law as a function of the ratio  $t/T$ .

In the case of an equipment in which no replacements are made in event of failure, the mean time to failure is that time at which the reliability has dropped to  $1/e = 0.37$ . If we consider a single

equipment in which each failed part is replaced immediately after failure, the failures will tend to occur randomly in time at a constant average rate,  $r$ , and  $T$  is then the average time between failures.

If there are a number of component parts or equipments functionally in series and if the reliability of each is governed by the exponential law, then the reliability of the series system, that is, the probability that there will be no failures within a time interval  $t$ , is

$$R_S = (R_1)(R_2)(R_3) \dots (R_n) \\ = e^{-(r_1 + r_2 + r_3 + \dots + r_n)t} \quad (15)$$

where  $r_1, r_2, r_3, \dots, r_n$  are the individual hazards, each being independent of the value of  $t$ .

It is apparent that, in such a case, the hazards of the individual component parts add directly. Thus, if the equipment contains  $b$  tubes,  $c$  resistors, and  $d$  capacitors whose failure rates are  $r_b, r_c$ , and  $r_d$ , respectively, the exponential law equation for equipment reliability becomes

$$R_e = e^{-(br_b + cr_c + dr_d)t} \quad (16)$$

If it is found that the condition of constant hazard applies to a portion but not to all of the reliability problem, the exponential law equation may be combined with other factors to yield a complete equation for the reliability. For example, if early failures as shown by the initial portion of Figures 4-1 and 4-3 are followed by a period of essentially constant hazard, an equation such as

$$R_e = R_0 e^{-t/T} \quad (17)$$

may be used to express the total reliability, where  $R_0$  is the equipment reliability as affected by early failures during an initial operating period which is short in comparison with  $t$ , the operating time of interest, and  $T$ , the equipment mean life.

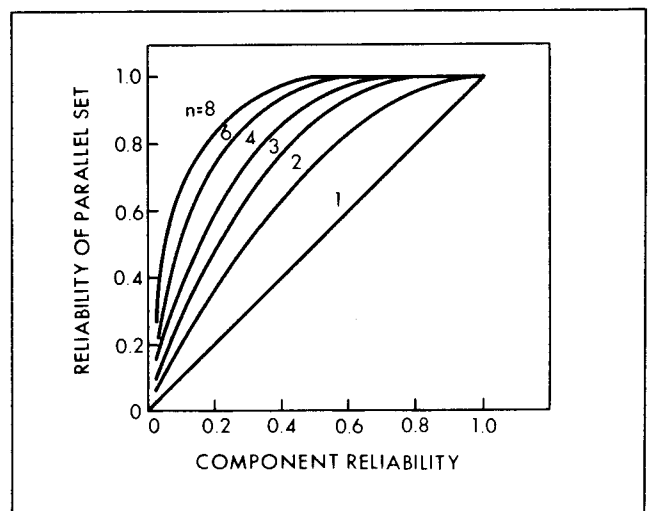

Figure 4-5. Reliability of "n" parallel components of equal reliability

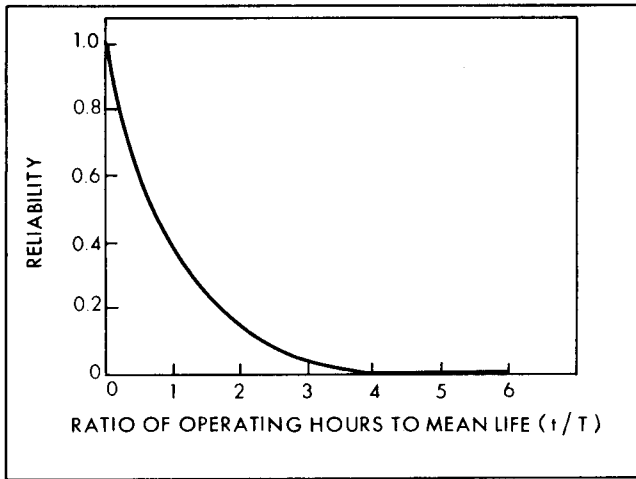

Figure 4-6. The exponential law of reliability

Similarly, the effect of design defects, maintenance practices, and so on, on equipment reliability can be taken into account by suitable multiplicative factors in combination with the exponential law equation.

The exponential law should not be accepted as generally valid in describing the reliability of electronic equipment. The best that can be said is that the limited amount of data collected to date appear to be in good agreement with the law, and that there are theoretical grounds for concluding that the exponential law should apply if certain conditions are fulfilled.

The exponential law describes the reliability of a set of elements in which failures tend to occur randomly in time, that is, "accidental" or "chance" failures, as contrasted to "wear-out" and other types of failures. Obviously, the law holds for an equipment composed of parts whose individual failures are exponential. Another important case of the exponential law occurs with a set of parts whose individual failures are not necessarily exponential but which are of mixed ages. In such a case, it can be shown that, because of the mixed ages of the component parts, the hazard for the set of parts as a whole tends to be constant, and the exponential law thus applies regardless of the failure patterns of the individual parts.

The "mixed ages" case is especially important in electronic equipment reliability because it is typical of the circumstances under which a large proportion of equipment is normally used. For example, the several electronic equipments required to mount a bomber mission will generally be of different ages. The exponential law thus applies to the several equipments as a whole, although it may not apply to any of them individually. Similarly, in an equipment that has been in operation for some time, and in which a large number of component part replacements have been made, the component parts will assume the attributes of a set having mixed ages, and the exponential law should apply to the reliability of the complete equipment, regardless of the failure patterns of the individual parts.

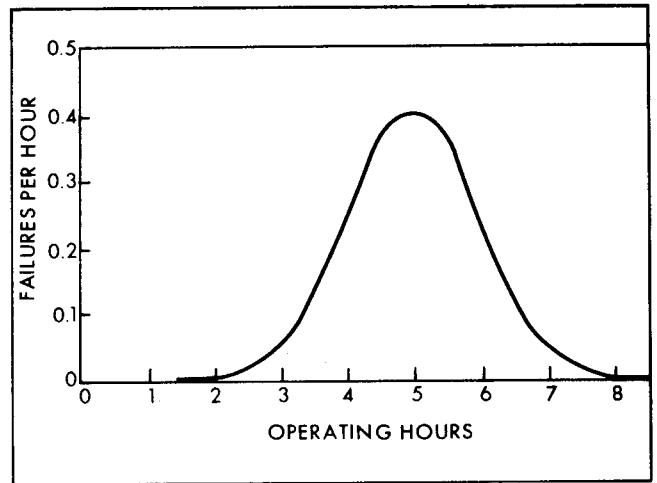

Figure 4-7. Gaussian distribution of failure rate

The Gaussian Law; "Wear-out" Failures. Of the infinite variety of possible forms of the failure rate curve, one special case deserves mention. This is the failure rate curve that characterizes what are termed "wear-out" failures. The wear-out failure rate curve, whose shape is illustrated in Figure 4-7, generally follows the familiar "Gaussian law" of probability.

The equation for a curve such as shown in Figure 4-7 is

$$Y = \frac{1}{\sigma \sqrt{2\pi}} e^{-\frac{(t - T)^2}{2\sigma^2}} \quad (18)$$

where Y is the failure rate per component part at the start of the test, t is elapsed operating time, T is the mean time to failure, and  $\sigma$ , the "standard deviation," is a measure of the spread of the failure distribution about the mean value T.

Distributions of the Gaussian type are important in the subject of probability because they are typical of the distribution of values of a controlled variable whose departure from its mean, or "nominal," value is the result of random factors. For example, the distribution of actual values of transconductance of a particular type of electron tube can be expected to approximate a Gaussian distribution.

In electronic equipment reliability, the fact that "wear-out" failures follow the Gaussian law implies that wear-out life is a controlled variable. From Figure 4-7, it is seen that there are few very early or very late failures. The failure rate is a maximum at the mean life, and drops sharply for operating times longer or shorter than the mean life. The width of the failure rate distribution (described more precisely by its standard deviation) is a measure of the excellence of life control.

Whereas a failure rate distribution such as illustrated in Figure 4-1 is the result of randomly occurring events beyond the capabilities of the component part to withstand, wear-out failures are caused by gradual deterioration or depletion resulting from



increased use or age. Considerable significance may be attached to the fact that data collected to date indicate that electronic equipment tends to follow the failure distribution of Figure 4-1 much more closely than that of Figure 4-7.

Reliability and hazard can be obtained from a curve, such as Figure 4-7, by the same means used for Figures 4-1, 4-2, and 4-3. Inspection of Figure 4-7 discloses that the reliability is high initially, dropping sharply as the failure rate increases in the region of the mean life. The hazard is also very low initially, rising rapidly after the mean life has been passed. With wear-out failures, unlike the case illustrated in Figures 4-1, 4-2, and 4-3, the failure rate of the survivors (hazard) depends strongly on how long they have operated.

A Typical Problem. As an example of the application of probability theory to the quantitative prediction of electronic equipment reliability, consider the following hypothetical case.

A proposed electronic equipment, to be procured in substantial quantities for a "critical" mission, will contain an estimated 50 tubes. It is desired to determine the following:

1. The reliability of the equipment as a function of operating time.
2. The quantity of spare complete equipments that should be provided to assure that a certain minimum number of equipments will always be available for use.
3. The number of spare component parts of various types that should be carried in replacement parts stocks.

A typical electronic equipment has roughly 10 parts, such as resistors, capacitors, relays, and transformers, for each tube in the equipment. Thus, we may conclude that the hypothetical equipment under consideration will contain approximately 50 tubes and 500 other component parts. Data (also hypothetical) on various equipment types operated under circumstances similar to those for the proposed equipment showed tube and component part failures occurring randomly in time, with constant hazards of about 0.0007 failures per hour for tubes and 0.0002 failures per hour for all other parts in aggregate.

Thus, we can apply the exponential law of reliability,

$$R_e = e^{-(ar_a + br_b)t} \quad (16^1)$$

where

$$a = 50$$

$$r_a = 0.0007$$

$$b = 500$$

$$r_b = 0.0002$$

whence  $R_e = e^{-(50 \times 0.0007 + 500 \times 0.0002)t} = e^{-.135t}$

The equipment reliability as a function of operating time is plotted in Figure 4-8.

On the subject of the number of spare complete equipments required, it will be remembered that the equipment mean time to failure,  $T$ , is the reciprocal of the total hazard, or

$$T = 1/.135 = 7.4 \text{ hours}$$

This is also the value of operating time at which equipment reliability has dropped to  $1/e = 0.37$ . Thus,  $T = 7.4$  hours is the average length of time between failures for each equipment. If it is assumed that an average of one hour will be required to repair each failure, one hour of maintenance will be required for each 7.4 hours of service, on the average. The ratio of the total number of equipments required to the total required to be in operation simultaneously is then  $8.4/7.4 = 1.14$ . Thus, about 15 percent spare equipments should be provided.

If experience has shown that "early failures" with equipments similar to the type being considered may run as high as 20 percent of the total number of equipments, it may be necessary to provide for more than 15 percent spare equipments to assure that the required number will be in operation during the early failure period. (It is assumed, of course, that early failures are repairable, although the time required may exceed that for repair of later failures because of the nature of the early failures.)

The number of spare parts required can be determined directly from the tube mean life  $T_a = 1/r_a = 1,400$  hours and component mean life  $T_b = 1/r_b = 5,000$  hours. Thus, the number of spare tubes required per tube per equipment will be equal to the total equipment life, in hours, divided by 1,400. The number of spares required for each component part in each equipment will be the total equipment life divided by 5,000. If the equipment must be maintained from stocked spares for an average of 23 hours of operation per day for two years (730 days,

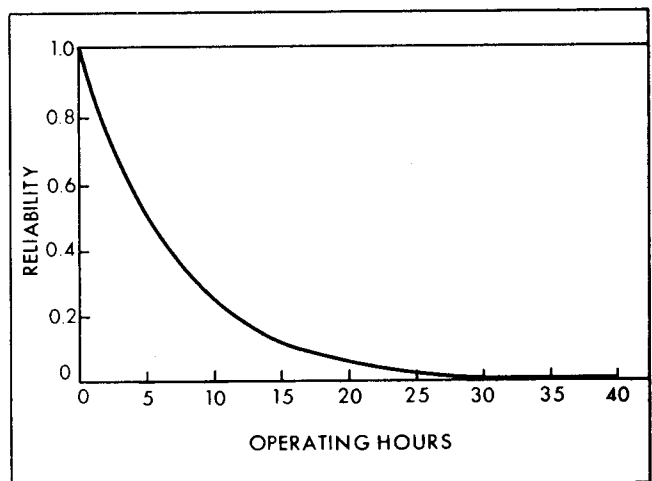

Figure 4-8. Equipment reliability with 50 tubes and 500 other components

16,790 hours of operation), spares must amount to  $16,790/1,400 = 12$  tubes per tube per equipment, or a total of 600 spare tubes of all types per equipment, and  $16,790/5,000 = 3.4$  component parts of each other type per part per equipment, a total of 1,700 spare parts per equipment. In view of the possibility of sympathetic failures, these figures are probably too small rather than too large.

During the two-year period, almost 2,000 hours of maintenance will be required to keep one equipment in operation.

#### SOURCES OF RELIABILITY DATA

The mathematical theory of reliability is of limited value without adequate data to which the various formulas may be applied. Such widely-scattered reliability data as exist at this writing have been collected as the result of independent, uncoordinated efforts, and much of it is of no value for statistical treatment. Instead, such data give only a qualitative picture of reliability. Fortunately, the literature shows evidence of a rapidly increasing awareness of the need for and the nature of good reliability data, and it is to be expected that better reliability data will become available as soon as the difficulty of the collection problem permits.

Reliability Data Requirements. To be useful for the quantitative prediction of equipment and system reliability, reliability data must fulfill a number of requirements:

1. The data must be quantitative rather than qualitative in nature.
2. It must apply to the operating conditions, such as application and environment, for which reliability is to be determined.
3. It must be accurate. That is, it must have been collected by reliable sources according to an established plan compatible with the application to which the data is to be put.
4. It must be statistically significant. That is, it must represent the results of a sufficient number of tests or samples to be a valid basis for statistical prediction, and the test samples must be truly representative of the component parts to which the prediction is to be applied.
5. It must take account of all factors in the reliability problem, including such factors as maintenance practices and possible component part misapplication.

As will be seen from the discussion that follows, the majority of existing "reliability" data are deficient on one or more of these points.

Published Reliability Data — "Guaranteed" Life. One of the most obvious sources of reliability data lies in the characteristics that many component

part and equipment manufacturers publish in the form of product "specifications." Such data frequently include a "guaranteed minimum life" in terms of number of hours of operation, number of operating cycles, and so on, which the part is guaranteed to withstand without failure.

The greatest shortcoming of such information in predicting equipment reliability lies in the meaning of the guarantee itself. Most often, the terms of the guarantee specify that the manufacturer is willing to replace any part that proves defective within the period of the guarantee. Thus, the guarantee not only is a measure of the quality of the product, but it also takes into account the manufacturer's willingness to risk being wrong. A guarantee of this sort ignores the basic nature of component life as a probability distribution and, instead, classifies the problem into the qualitative categories of "good" and "no good" without any indication of the relation of these categories to the true distribution of failure rate or reliability.

A further shortcoming of the "guarantee," which is shared by almost all existing reliability data, is that it applies only to a particular set of operating conditions, or at best to a limited range of operating conditions, and cannot readily be extrapolated to other conditions of application.

Laboratory Life Test Data — Military Specification Requirements. Many military specifications for electronic components, notably military tube specification MIL-E-1, require life tests under specified conditions. A certain number or percentage of samples is selected from each lot and is subjected to life tests. The entire lot is then accepted or rejected on the basis of the number of test samples that survive the test. Although probably adequate for their principal purpose of maintaining a certain level of quality in parts of the lots tested, such tests are of little value as a basis for predicting the reliability of equipment incorporating the component parts.

In the first place, the life tests are conducted under a set of operating conditions deliberately chosen as severe, and the results cannot be applied to operating conditions that are either more or less severe than the test conditions. In many cases, the discrepancy between the operating conditions specified in military component part specifications and those specified for equipment incorporating the parts is quite marked.

In the second place, the life tests are for one particular operating period, and give no indication of the results that would have been obtained with some other operating period. Thus, the test data cannot be related to the life distribution.

Data Supplied by Operational Groups. For some time, the military agencies have had in operation programs whereby activities in the field make reports on equipment troubles and failures that they encounter. The Unsatisfactory Report, or "UR," is typical of such reports.

The best that can be said for the Unsatisfactory Report is that an accumulation of several reports of

similar difficulties with the same equipment type is a clear indication that trouble exists. However, individual reports frequently lack both accuracy and objectivity, failing to give a clear description of the nature of the difficulty encountered, and often attributing it to incorrect causes.

On the other hand, data from operational groups has the advantage, not shared by many of the other types of data, that it has actually been collected under field conditions.

The principal application to the reliability problem of data from operational groups lies in the collection and analysis of large quantities of such data to determine the general pattern and trends of equipment failure.

Data from Controlled Tests. Obviously the best method of obtaining component part reliability data is the conduct of controlled tests that accurately simulate the conditions under which reliability is of interest. Unfortunately, the tests that would be required to evaluate the reliability of all component parts to be incorporated into an equipment are usually beyond the practical scope of an equipment design program.

Consequently, it is to be hoped that the military agencies, possibly in cooperation with component part manufacturers, will sponsor such tests for various part types operating under various conditions, and will make the results of these tests generally available to equipment designers. An excellent start in this direction has been made by the ARINC program discussed elsewhere in this handbook. In fact, the ARINC works appears to be the only program instituted so far to obtain statistical reliability data on military equipment in the field.

For special problems, such as those involving only a few critical component part types, the conduct of controlled reliability tests may be within the scope of an equipment design program. Such a program can be especially rewarding if effort is concentrated on improvement of the reliability of a few component parts whose reliability is outstandingly poor. A report by the U. S. Naval Air Missile Test Center includes a discussion of the relation between the number of samples subjected to such tests and the degree to which the test results are indicative of the characteristics of all the component parts in the sampled lot./3/

Data by Inference from Past Experience. It is always a temptation, when data are not available relating to the situation at hand, to assume that data relating to some other situation can be extrapolated or interpolated to the new situation. Intelligent interpolation is generally less dangerous than extrapolation, but both are to be avoided whenever possible.

However, inference is sometimes the only available means of obtaining reliability information, and in such cases it is better than no means at all, providing the confidence placed in the result is not

excessive. If good data are available to indicate the reliability of a particular type of component part at 80 hours and at 100 hours, and if the data indicate no sharp changes between these values, the 90-hour reliability may be obtained by interpolation with considerable assurance. On the other hand, 100-hour reliability data is a poor basis for estimating 500-hour reliability, and vice versa.

Generally speaking, inference is a better method of obtaining qualitative reliability data than it is as a basis of quantitative prediction.

By now, it should be obvious that a great deal more (and better) reliability data than is now available will be required before the electronic equipment reliability problem can be considered solved.

Qualitative Use of Reliability Theory. Fortunately, one does not require a large amount of reliability data to benefit from an understanding of the mathematical aspects of electronic equipment reliability. Much useful information can be drawn directly from the theory, and it can be made the basis of necessary decisions even though specific data may be lacking.

Perhaps the most striking import of the reliability data collected to date is the prevalence of component part failures occurring randomly as a function of operating time — the "chance" failures giving rise to the exponential law of reliability. In the case of individual parts whose reliability follows the exponential law, the failure behavior cannot be explained on the basis of "mixed ages." Rather, it must be the result of so-called "accidental, unexpected or unusually severe conditions arising during the operating period."/2/ Now the conditions to which electronic component parts are subjected are hardly any more "accidental" or "unexpected" than the treatment received by automobile tires, whose failure pattern does not noticeably follow the exponential law but is of the wear-out type described by the Gaussian law.

Thus, it may be concluded that failure of electronic component parts has been the result of "unusually severe" conditions, in the sense that the conditions are not those that the parts are designed to withstand. In brief, historical evidence shows that electronic component parts are not designed for reliability. The absence of a controlled process whose objective is reliability is evidenced by the fact that failures do not group in the manner that is typical of the values resulting from a controlled process, but instead occur randomly in time.

In the manufacture of resistors, for example, the distribution of resistance values at the output of the manufacturing process is essentially a Gaussian distribution. The mean value of the distribution is very nearly, if not exactly, the nominal value of the resistors that the process was intended to yield. The width or "spread" of the distribution (measured by the standard deviation) is related to the resistor tolerance, and is an indication of the closeness of manufacturing control. A random distribution of resistor

values would be obtained from a manufacturing process subject to essentially no control, and the attainment of desired resistor values would be possible only by virtue of selecting from the output of the complete process those resistors that fall within the desired limits.

Attainment of electronic component parts of a desired degree of reliability solely by means of such a selection process is as undesirable as the corresponding means of obtaining desired resistance values. However, only the very recent history of the reliability problem shows evidence of attempts to secure component part reliability by means other than selection.

At least part of the difficulty is occasioned by lack of any definite statement of reliability requirements. All too often, requirements are stated in terms that amount to "infinite reliability," without a realistic appraisal of the necessary compromises between reliability and other performance factors. The situation is parallel to attempts to design a "universal" artillery piece, capable of annihilating an enemy at any range from 10 yards to 1,000 miles, without recognition of the vast differences in the terms of the problem between its two extremes.

The future progress of electronic reliability depends in large part on the formulation and promulgation of realistic reliability requirements for various types of service, and on the intelligent use of these requirements by component part and equipment designers.

Curves such as those in Figures 4-4, 4-5, and 4-6 shed much light on the reliability problem, even in the absence of specific data applicable to a particular problem at hand. From Figure 4-4, it is evident that increasing the complexity of equipment will cause the equipment to become much less reliable. The only remedies for this situation consist of either minimizing the complexity or increasing the component part reliability, or both. Unfortunately, the increase in component part reliability required

to compensate for even a moderate increase in complexity may be quite expensive. This is particularly true if component part reliability is already in the region above 0.99, in which region further increases in reliability are tremendously expensive and time-consuming.

Figure 4-5 suggests an alternative means of increasing the effective reliability of weak component parts by paralleling them with other parts on a standby basis. The paralleling method can be especially effective if poor equipment reliability is caused by a small number of part types whose reliability is markedly lower than the remainder. The effectiveness of improvements in the reliability of such weak component parts can be readily assessed in terms of the effect on the geometric mean reliability of all the parts in the equipment. Paralleling of complete equipments, while effective in increasing system reliability, should be adopted only as a last resort if increased reliability is especially critical and cannot be achieved by other, less expensive means.

In determining where efforts toward increased reliability can best be concentrated, a rough priority system can be set up by ranking the various component part types in the order of their reliability and then multiplying the various rank numbers by the quantity in use of parts of the corresponding type. Thus, reliability improvement efforts can be concentrated where they will do the most good, either by making major improvements in the reliability of particularly poor component parts used in small numbers, or by more modest improvements in components used in larger numbers. The most accurate test of the effectiveness of such efforts, of course, is in terms of the geometric mean reliability of all components in concert.

Figure 4-6 shows the effect of increased operating time on equipments whose reliability follows the exponential law. Reliability drops sharply, and for most applications becomes intolerably poor at an operating time which is only a fraction of the equipment mean life,  $T$ .

## REFERENCES

1. Huff, Darrell, How to Lie With Statistics, W. W. Norton & Co., 1954.
2. Carhart, R. R., "Survey of Current Status of the Electronic Reliability Problem," Report No. RM-1131, The Rand Corp., Santa Monica, Calif., August 14, 1953, p. 81.
3. Lusser, Robert, "A Study of Methods for Achieving Reliability of Guided Missiles," U. S. Naval Air Missile Test Center, Technical Report No. 75 (Restricted), 10 July 1950.

## BIBLIOGRAPHY

- Acheson, Marcus A., "Electron-Tube Life and Reliability," The Sylvania Technologist, Vol. II, No. 2 and 3, July 1954, and continued in subsequent issues.
- Acheson, Marcus A., "Electron-Tube Life and Reliability; Variation of Life Performance with Usage Conditions," National Conference of Airborne Electronics, May 1954.

Bross, Irwin, D.J., Design for Decision, The MacMillan Company, 1953.

Frantik, R. O., "The Determination, Application, and Limitations of Circuit Reliability Equations," Sandia Corporation, Report No. SC-3288 (TR), April 26, 1954.

Fry, Thornton C., Probability and Its Engineering Uses, Van Nostrand Company, Inc., 1928.

Landers, Richard R., "Improving Reliability of Electronic Equipment by Effective Analysis of Field Performance," IRE National Convention, 1954.

Lusser, Robert, "General Specifications for the Safety Margins Required for Guided Missile Components," U. S. Naval Air Missile Test Center, Technical Report No. 84, 10 July 1951.

Lusser, Robert, "Planning and Conducting Reliability Test Programs for Guided Missiles," U. S. Naval Air Missile Center, Technical Report No. 70, 20 June 1952.

Progress Report on Reliability of Electronic Equipment, Research and Development Board, Committee on Electronics, Ad Hoc Group on Reliability of Electronic Equipment, February 18, 1952.

Warsher, A., "A New Approach to Attainment of Reliability in the Production of Airborne Electronic Systems," IRE National Convention, 1954.

Widrewitz, J., "Mathematical Evaluation of Electronic System Reliability," Rome Air Development Center, Technical Note No. RCRP 52-11, December 1952.

# CONTENTS

## chapter five **electrical and electronic factors**

General Rules for Good Military Circuit Design

Component Part Selection and Use

Component Part Stability

Comparative Circuit Reliability

Preferred Circuits

Notes on Proper Tube Applications

Marginal Testing

Redundancy as a Reliability Asset

Electrical Hazards

# ELECTRICAL AND ELECTRONIC FACTORS

Whether or not radio engineers should be good mechanical engineers is a subject for much discussion and many arguments. It is a fact that most purchasers of industrial electronic apparatus who have been dissatisfied with their purchases have blamed the trouble on poor mechanical engineering rather than on the electronics involved. It is also a fact that the electronics engineer has more business knowing the basic facts of good mechanical design than the other way around — the mechanical engineer is likely to turn the electronics over to an expert.

No matter how this argument goes, the radio engineer must know his electronics. And he must know his subject from many aspects — efficiency, cost, ease of manufacture, installation, operation, maintenance, and, finally, from the standpoint of reliability. Many circuits can be chosen, or invented, to perform the same function, but there are few basic assemblies of the essential ingredients of tubes, resistors, capacitors, and inductors. All other circuits are mere adaptations of these basic assemblies.

It is in the selection of the final circuit configuration to be employed in production models that the radio engineer can show his greatest skill, exercise his greatest restraint, and produce a device that is most efficient, economical, reliable (or whatever the main criterion may be) — or he can be the individualist seeking to get his name attached to something that is new and hotter than a firecracker.

In the following pages, notes on circuit design will be found in which the emphasis is on reliability. And, so far as efficiency and economics are concerned, it will be assumed that the definition of these terms has little in common with the conventional urge in the home radio and television laboratory — how to get the most performance per dollar, and never mind the service costs!

General Rules for Good Military Circuit Design. The following items are only suggestive.

The designer can make up his own list, and at much greater length. But they are likely to be rules on which good ultimate design will be based.

1. Make the circuit as simple as possible. If an extra resistor or tube is employed, make sure it is worth its cost, space, weight, replacement time, and so on, in terms of what good it does.
2. Use circuits that are basic, tried-and-true, and are known to work. Such circuits are easier to service by maintenance personnel than more complex or newer circuits whose functioning may be new or hard to explain.
3. Use circuits that will work properly over a wide range of tube and component characteristics. In other words, avoid critical circuits that call for hand-selected tubes, or that will not perform the required function when tube emission has dropped somewhat.
4. Avoid circuits that require a high degree of voltage regulation.
5. Design circuits that are intrinsically stable. They will require less shielding and less voltage regulation, will use components of wide tolerance in wide manufacture (and are cheaper), and will require fewer knobs on the front panel. They will be easier to manufacture. They are inherently desirable for every reason.
6. Avoid dual-purpose circuits. A circuit that performs a single job is likely to be more reliable than one that has to do several jobs. The popular reflex circuits of earlier days went out of the picture because they were difficult to maintain, even if they did perform a job economically.

Component Part Selection and Use. The vendors of component parts are very vocal in their belief that unreliability because of components is largely due to misapplication. They cannot be blamed if they claim that their products will be reliable if used properly. They are absolutely right. But "no components manufacturer will ever produce a component which some engineer will not push to its threshold of operation in dubious circuitry and in confined space to guarantee heat failure."/1/

It is up to the designer of circuits and apparatus to know what will be required of the component parts in actual field use, to select components that will stand up under these conditions, or to redesign the equipment so that existing components will stand up. This is the responsibility of the equipment designer and manufacturer.

After having chosen component parts and environment so that the parts will stand up, the designer's next problem is to design his circuits so that normal variations in component part values — tolerances in manufacture, changes in characteristics with heat, humidity, age — will not disable the circuits. It is not enough to design a circuit that calls for 1 percent resistors for proper operation and to let the matter go at this point.

Component Part Stability. "Stability of any component is always in question. The 1 percent resistor does not always stay within 1 percent under various conditions of temperature and humidity and, very often, after several thousand hours, resistors change their values. The result can be catastrophic if one is dependent upon their being stable. The vacuum tube and the crystal diode are also very vulnerable on this point of stability, and should never be used where tolerances of more than 10 to 20 percent are expected."/2/

And it seems rather idle to specify and rely on 1 percent resistors when tubes and diodes are not made to any such stringent tolerances.

In the chapter on Component Parts, some of the basic principles of component part selection and use are discussed in greater detail.

The techniques for designing circuits to tolerate wide changes in component part and tube characteristics cannot be overemphasized. The designer seldom has full control over his brain children when they go into volume production. Components of a given type made by two different manufacturers may have the same initial characteristics but, because of different manufacturing process, may change in different direction and degree with time and environment. "Circuits must be designed to accept the full JAN limits. It is not difficult to obtain a JAN tube which operates within limits narrower than those specified. But when the equipment gets into production (or in the field) a different manufacturer may provide the tube. This factor may result in the circuit not operating because the second manufacturer's limits are different from those which the first manufacturer selected, although both limits are within the range specified by JAN specifications."/3/

The technique of marginal checking is an aid in determining the tolerance of a particular circuit to variations in component parts values. To change the parts values, one at a time, over a wide range, would be a tedious and timeconsuming course. Since many of the changes and their effects can be simulated merely by changing a voltage, which is the essence of marginal checking, this technique can be very helpful in determining circuit tolerances.

Simple Circuits Are Best. While highbrow engineers who are familiar with modern information theory seem to be coming up with the idea that a more complex arrangement of anything is likely to be more reliable than a simple one, it is still good practice to use simple circuits.

The fantastic increase in the use of cathode followers as a means of lowering the impedance level or as coupling tubes is an example of where an extra tube does a nice job but where it may not always be worth it.

On the other hand, the engineer must go out of his way to add a tube if the addition will prolong the life of other parts of the device. It is easy to locate tube trouble, and it is easier to replace a tube than to find (or replace) the particular component part that causes failure. In other words, the extra tube is amply justified from the standpoint of reliability.

Studies undertaken by Muncy of the Bureau of Standards /4/ indicate that circuits performing identical functions may have widely differing numbers of resistors or capacitors, the actual number depending upon the engineer who built it, or his mental condition at the time. It is certain that a considerable degree of circuit standardization could take place, with an increase in reliability and a decrease in maintenance time, yet without restricting the designing engineer to any degree. There will always be plenty of scope for the inventive circuit man.

Trick Circuits. New and untried circuits are to be avoided in critical equipment. They can be tried out on phonograph amplifiers or morale-building equipment, or sold to the radio and TV industry. After they have been proven to work reliably, they can be added to new equipment that really has to work.

A new circuit, even if proven to be reliable, imposes new problems on the maintenance personnel. Special care, with careful explanation of the circuit principles, must be devoted to the circuit in the instruction and maintenance manuals. Circuits that are unfamiliar to the average maintenance man should be especially reliable, so that they can be packaged as units and repaired or removed as units. In that case, no special knowledge of the circuit functions or principles need be had by the maintenance technicians.

## COMPARATIVE CIRCUIT RELIABILITY

Aside from catastrophic failures of tubes or other parts, which cause complete stoppage of the equipment, reliability is concerned with circuit stability, that is, the ability to perform satisfactorily over a given length of time without adjustment or manual



correction and without undue twiddling of the knobs. Stability, therefore, concerns the problems of drift and aging of the equipment and its component parts./5/

In the paragraphs that follow, several methods by which particular circuits have been altered or designed to improve their stability are given.

**Voltage Divider Circuit.** An example of a very simple design problem /5/ where stability could be important is the following situation. Suppose a voltage divider is desired, operating from +150 and -150 volts, to provide bias for a clipper circuit adjustable from +1 to -1 volt. The input impedance of the clipper circuit is 1 megohm. A perfectly reasonable design, proceeding directly from the statement of the problem, could be as shown in Figure 5-1. Assuming  $\pm 1$  percent tolerances for the two series resistors and the two supply voltages, it is readily shown that a design tolerating all tolerances would have to be as indicated in Figure 5-2. To obtain the required voltage range under all tolerance conditions, the actual range of the control has to be increased 2.5 times, which makes the control more critical. Furthermore, the output voltage from the bleeder would be highly sensitive to any variation in the ratio of the two power supply voltages that might occur in the course of operation.

In Figure 5-3, we may use 10 percent tolerance resistors, and the nominal range of the control is only 30 percent greater than the voltage range required to accommodate all tolerances. In addition, variations in the supply voltages are divided down so that they

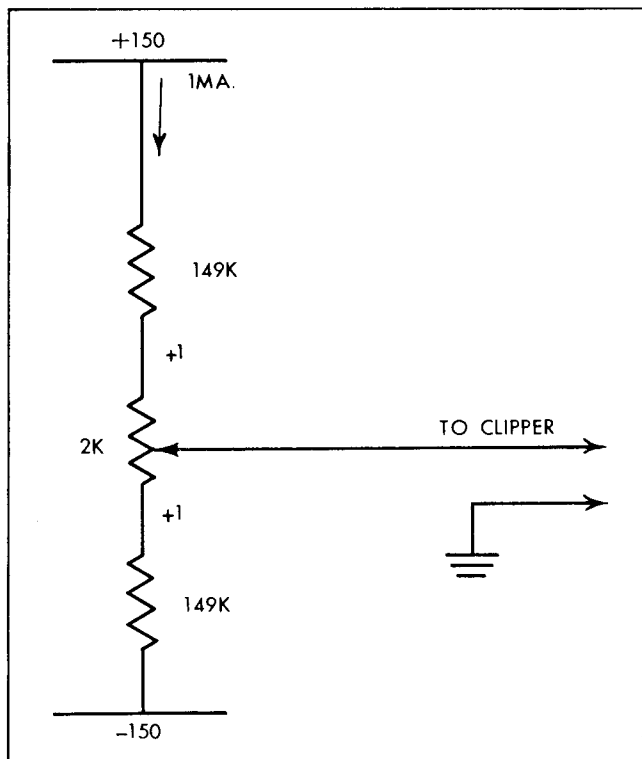

Figure 5-1. Simple voltage divider

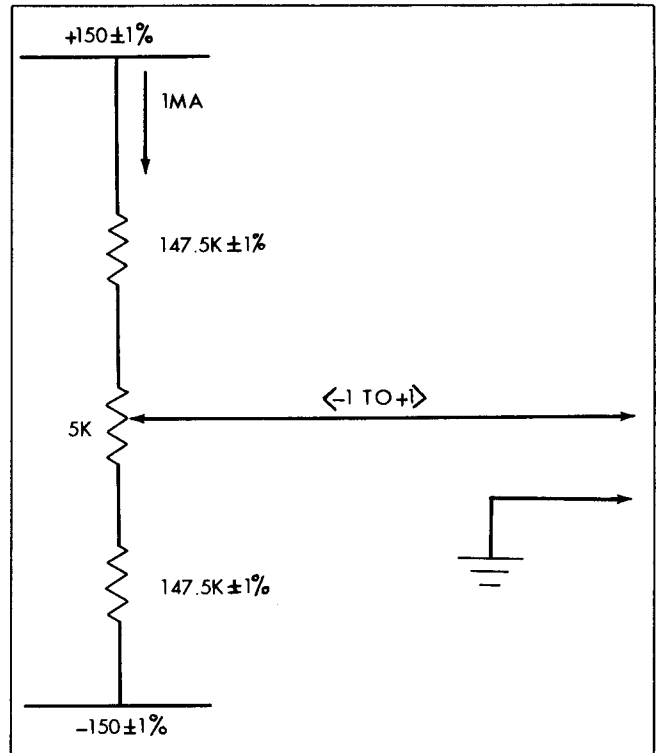

Figure 5-2. Voltage divider with resistors having tolerances of  $\pm 1$  percent

cause only  $\pm 1$  percent change of the 1-volt output, which would probably be completely negligible. A very simple circuit change has eliminated a critical tolerance problem and greatly reduced the supply voltage sensitivity.

**Monostable Multivibrator.** Another example of circuit stabilization, also due to Luther, shows the methods by which stability, as a design factor, can be approached and the endpoint achieved. This circuit, Figure 5-4, was intended where use with a high degree of independence of tube characteristics and supply voltages was desired and where the least number of tubes and other parts possible, with a minimum of wasted power, was a requirement.

The two tubes are cross-connected from plate-to-grid with one direct-coupled path, required for a monostable multivibrator, and one a-c coupled path for timing.  $V_2$  is normally conducting, and the voltage drop across  $R_1$  maintains the grid of  $V_1$  below cutoff. Diode  $V_3$  conducts, holding the cathode of  $V_1$  at +70 volts, which allows  $V_1$  to be maintained at cutoff by a relatively small drop across  $R_1$ .

A negative trigger pulse, introduced via  $C_1$ , is coupled to the grid of  $V_2$  through  $C$ .  $V_2$ , therefore, is driven toward cutoff, causing the voltage across  $R_1$  to decrease, which in turn renders  $V_1$  conductive. The plate voltage of  $V_1$  drops rapidly, causing the grid of  $V_2$  to be driven far beyond cutoff. At this point, the timing cycle begins, with  $C$  discharging through  $R$ , causing the voltage at the grid of  $V_2$  to rise. After some time, determined by the initial voltage  $E_3$

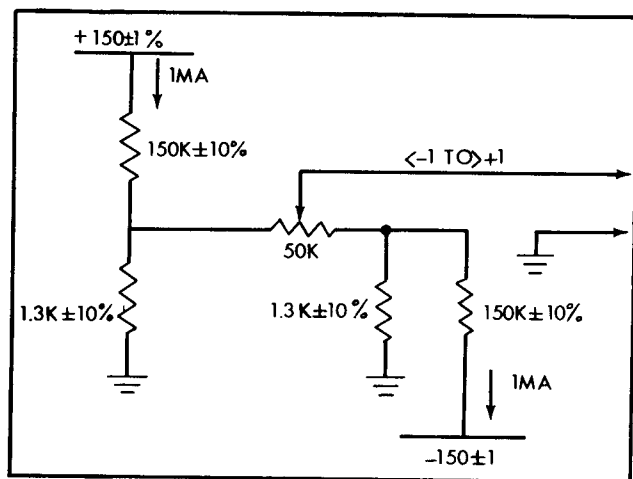

Figure 5-3. Voltage divider with resistors having tolerances of  $\pm 10$  percent

across  $R$ , the drop  $E_1$  in  $V_1$  plate voltage (when this tube is turned on), the cutoff voltage  $E_2$  of  $V_2$ , and the time constant  $RC$ ,  $V_2$  will again conduct, and the circuit will regeneratively return to its initial state to await the next trigger pulse.

Stability of the pulse width is achieved by controlling all four determining factors listed above. The voltage  $E_3$  is made equal to the 70-volt power supply by grid-current clamping in  $V_2$ . The effect of  $V_2$  cutoff voltage  $E_2$  is made small by choosing a sufficiently large timing waveform amplitude  $E_1$ . The amplitude  $E_1$  is stabilized by negative feedback in the cathode circuit of  $V_1$  in the following manner. During the time  $V_1$  is conducting,  $V_2$  will be completely cut off, so that the grid voltage of  $V_1$  will be exactly 70 volts. If the required plate current of  $V_1$  is not too large, the tube will operate at a small negative bias of such a value that the  $V_1$  cathode voltage is slightly more positive (one or two volts) than its grid. Thus, the diode  $V_3$  will cut off when  $V_1$  conducts, and all plate current of  $V_1$  will flow in  $R_k$ . The effect of tube aging is to change the difference between the grid voltage and the voltage across  $R_k$ . This change in tube bias is in such a direction that the peak value of  $E_1$  is maintained at the desired value. Thus, the peak current in  $V_1$  will depend primarily on  $R_k$  and the 70-volt supply voltage.

Consequently, all the significant voltage levels in the circuit are either regulated or made negligible. Reasonable care in the choice of  $R_L$ ,  $R_k$ ,  $R$ , and  $C$  can thus provide a pulse width having a high degree of stability.

Voltage stability is achieved by the proportionality method. The width is given by

$$t = RC \ln \frac{E_1 + E_3}{E_2 + E_3}$$

$E_1$  is closely proportional to the 70-volt supply, and  $E_2$  also shows a similar proportionality, since the 70-volt supply is the plate voltage on  $V_2$ . Thus, it is

only necessary to make  $E_3$  equal to the 70-volt supply and the value of this voltage will cancel out of the expression for pulse width. Similar stability to the 280-volt supply is provided by the current-regulating properties of the cathode circuit of  $V_1$ , although in this case the negative feedback is responsible.

Both  $V_1$  and  $V_2$  are operated in such a manner that deterioration of emission to one-half normal zero-bias plate current will not interfere with the circuit operation.

Experience with the circuit has shown that pulse width is reproducible to within  $\pm 5$  percent in production when  $\pm 1$  percent component tolerances are used, and if an initial adjustment is provided, highly reliable operation is possible within a 1-percent overall width tolerance. Typical performance of this circuit is given by Table 5-1 for a multivibrator having a pulse width of about 100 microseconds.

Table 5-1. Stabilized monostable multivibrator, having nominal width of 100 microseconds

Change in width (percent)	For following variations
1	Change of $V_1$ or $V_2$ or both, and aging to to 1/2 normal emission
0.8	Change of crystal diode for $V_3$ back resistance from 1 megohm to 20,000 ohms
0.05	10 percent change in 70 volts
0.1	10 percent change in 280 volts
--	10 percent change in $R_1$

**High-Speed Flip-Flop.** A widely quoted paper by Taylor /2/ is an excellent example of how designing engineers, by exercising their ingenuity and skill, can trade circuit complexity for greater stability and, therefore, for greater reliability. The technique of determining the tolerance limits of a circuit for variations of component values, or voltages, is given in this paper, and it forms a basis on which careful circuit study can be made, with an eye on the reliability problem as affected by stability.

In Figure 5-5, the inside diamond-shaped contour represents the failure locus of a flip-flop circuit designed to a specification for which component part tolerances were not of prime importance. The outside contour is one resulting from a circuit design for which the specification was given that the tolerances on the parts should be very wide and that no resistance demanding a 1-percent tolerance should be used. The two circuits have similar frequency responses and resolution times and perform interchangeably in the system. The area of performance is about eight times greater in the latter design, and the tolerance on any one component about double.

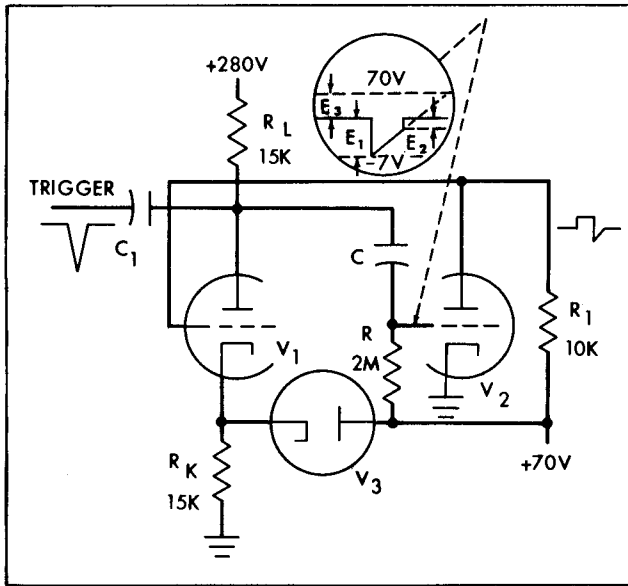

Figure 5-4. Circuit using a minimum number of components and having a high independence from effects of tube parameter and supply voltage variations

The straight lines represent measured failure contours. The extensions of the lines beyond the axes represent negative tolerance of the particular measurement being made. The two sides of the diamond with negative slopes represent tolerance contours of the lower resistance in the voltage divider to positive or negative excursions of the marginal voltage. The sides with positive slopes are for the upper sections of the divider.

The first circuit, with the lower margins of performance, is a dual-pentode flip-flop shown in Figure 5-6. It uses high-performance pentode tubes and high-precision cross-resistance in the network that determines which tube is to be on and which to be off. It is a typical Eccles-Jordan type circuit, widely used in many fields. The marginal checking voltage chosen to make the tolerance study is indicated as a voltage inserted at the base of the voltage dividing network.

An improved version of the first circuit is shown in Figure 5-7. It performs this same function with low-performance triodes. Cathode-follower tubes were used to link the two halves of the flip-flop together. They provide a decoupling medium between the grid of one triode and the plate of the opposite triode and allow wide-band video circuitry, using low-performance tubes. The grid of each cathode follower has two diode circuits, which limit the swing of the signal passed to the opposite tube and make the level of this signal insensitive to variation in the plate current of the driving tube.

Another way to look at the advantages of the newer flip-flop is shown in Figure 5-8, which presents allowable plate current variations in the tubes as a function of the marginal checking voltages inserted in

the grid circuit. With no voltage inserted, the older circuit can tolerate only a 30 percent lack of balance in the tubes, but even with balanced tubes, the older circuit can tolerate only about one-third the voltage unbalance tolerated in the new design. Tubes with imbalance enough to close in the outer lines and form a complete closed locus were unavailable, but it was estimated that an unbalance of about 70 percent in plate current would be the tolerance of the newer circuit.

It is realized that the second flip-flop circuit is more complex than the first, since four triodes plus several diodes were used, as against two pentodes. But the tubes were of the medium- $\mu$  type, which can be produced with small production variations and with grid spacing such that fewer intermittent shorts would be expected. High precision resistors were unnecessary. As compensation for the greater complexity, the designer realized a circuit in which the tolerances of the components could be allowed to vary over much wider limits than in the original circuit, less care had to be exercised in choice of components, simpler tubes could be used, and general circuit reliability was enhanced.

Self-Bias vs. Fixed-Bias Flip-Flops./6/ To permit divider tolerances in one direction, tubes of fixed-bias flip-flops should be operated above zero bias, that is, tend toward relatively high positive biases, although clamped by grid conduction to slightly above zero volts. Operation in this manner results in a loss of negative grid swing and, for this reason, a loss in divider tolerance in the other direction. Likewise, output swing, and hence the stability factor, is a direct function of tube plate-current capabilities. Supply voltages become, in addition, relatively

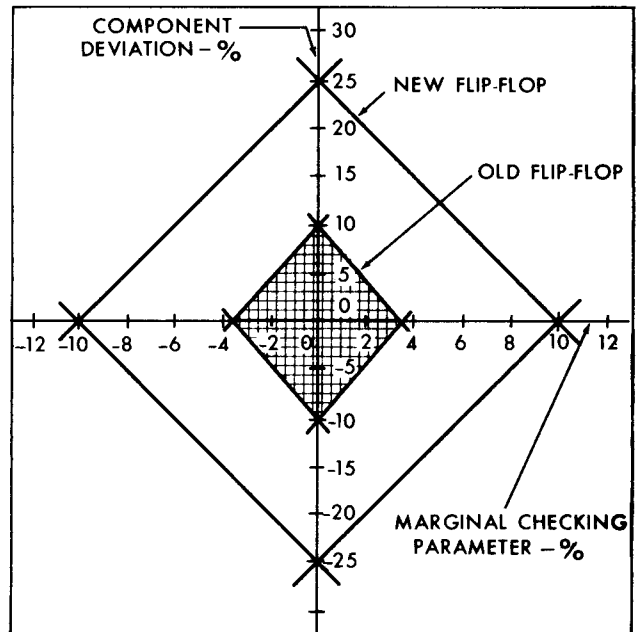

Figure 5-5. Stability comparison of new and old flip-flops.

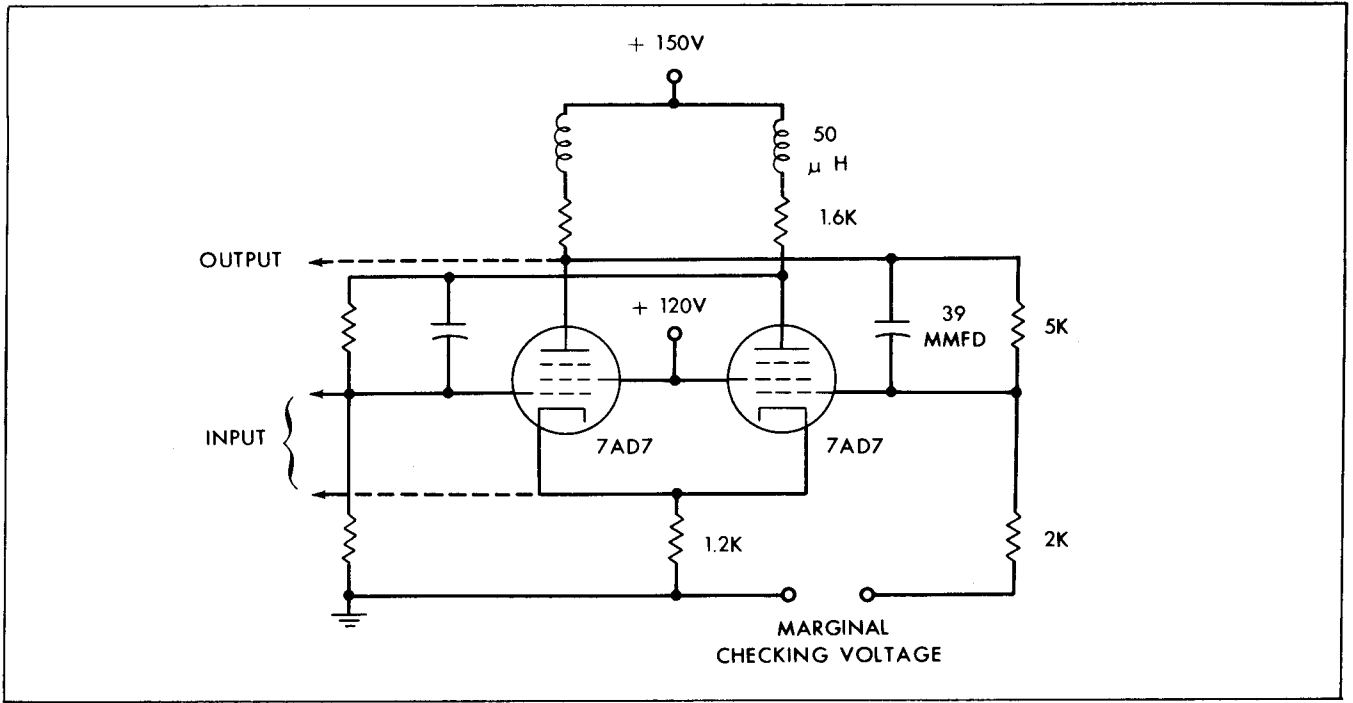

Figure 5-6. Dual-pentode flip-flop circuit

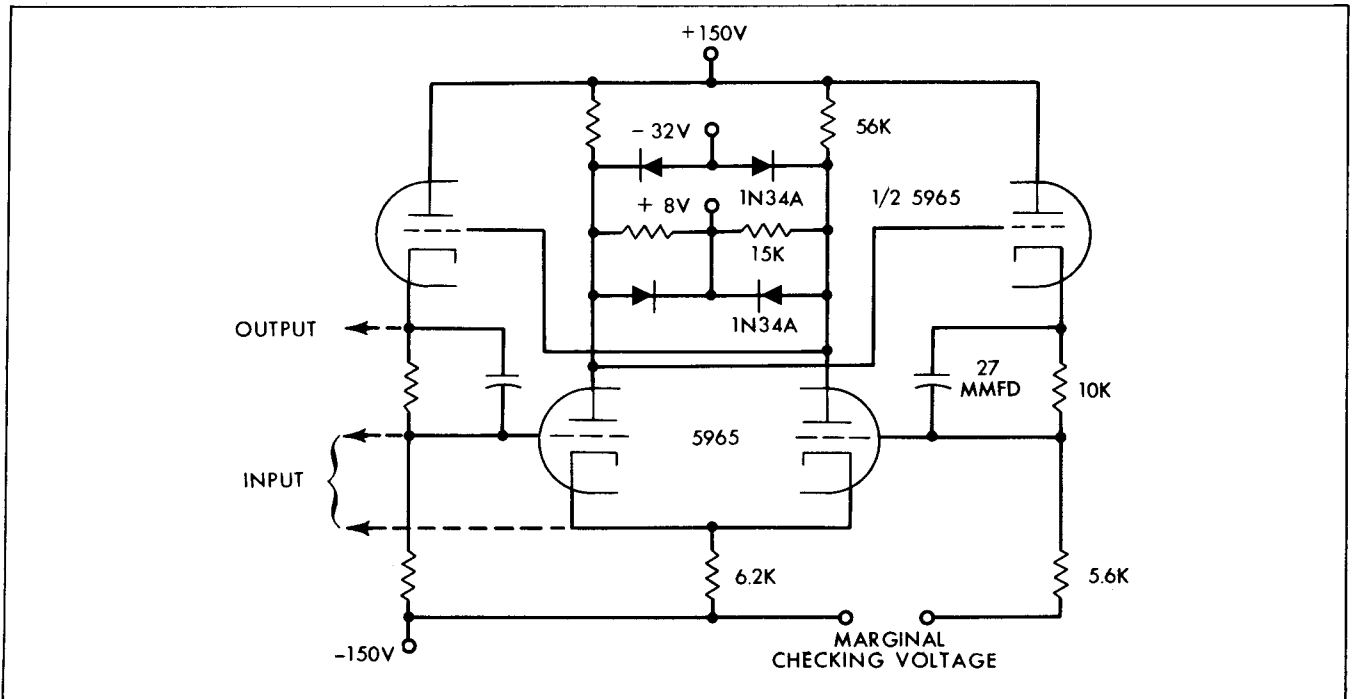

Figure 5-7. An improved flip-flop circuit

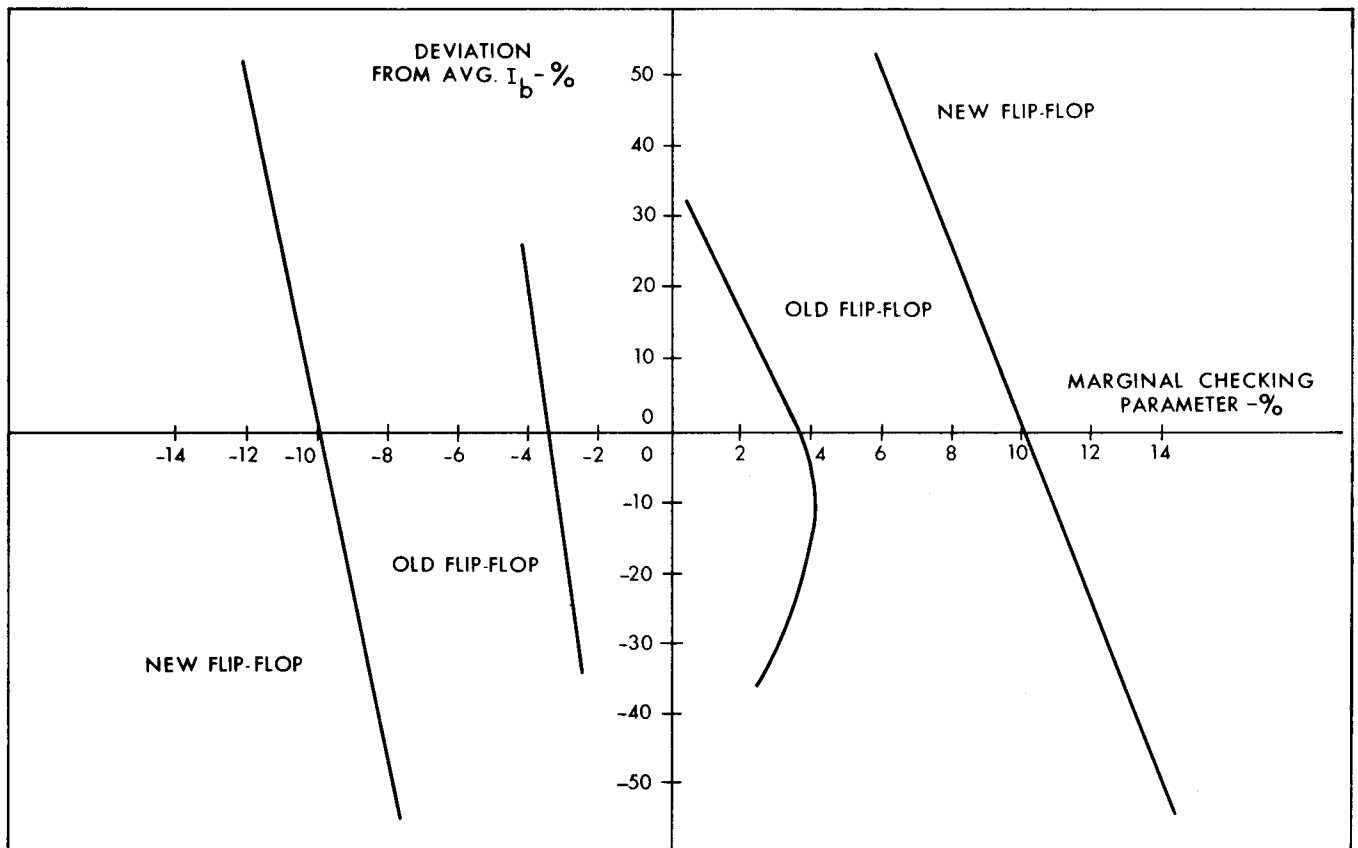

Figure 5-8. Effects of marginal checking voltages on plate currents. Comparison of old and improved types of flip-flop circuits is shown

critical. In comparison with self-bias types, fixed-bias flip-flops, in general, are not very reliable.

Self-bias flip-flops employing high-impedance dividers cannot supply an appreciable amount of grid current before causing rapid deterioration of output and grid swing and, at length, ultimate failure. If such a flip-flop is designed for zero-bias operation with average tubes, then the output swing, stability factor, tolerances, and so on, will be immediate and direct functions of the tube's negative plate-current tolerance. It is often desirable, therefore, to operate average tubes at a negative bias corresponding to zero bias of the worst tube (lowest  $I_p$ ) allowable. Then, output swing, grid swing, and cathode bias level would stay relatively constant up to the worst tube allowable.

Self-biased flip-flops employing low-impedance dividers, on the other hand, will allow much poorer tubes to be used on their circuits before they fail and may be operated close to zero bias for average tubes. In either low- or high-impedance divider circuits, clamping the lower level at the tube plates helps considerably in making the flip-flop insensitive to the plate current capabilities. Low-impedance dividers can be realized very effectively by use of cathode followers whose cathode resistances are those of the dividers. In addition to obtaining a low divider or grid impedance, thereby isolation of the flip-flop from its load, a capability for heavy loading, and fast resolution times are also realized.

**Transistor Oscillator.** Another example in which greater complexity was traded for greater reliability is given by Thomas, /7/ who described a transistor audio oscillator that was capable of using only about 10 out of 20 production transistors. By the addition of a diode to the base circuit, oscillation was possible with 999 out of 1,000 transistors.

#### PREFERRED CIRCUITS

There is no doubt that many circuits differing only in small details are now employed to perform identical functions, or that considerable standardization could take place in circuit design, without in any way inhibiting the creative abilities of circuit engineers. The work of Muncy /4/ has been mentioned elsewhere in this handbook. It has resulted in a most interesting and useful compilation of "preferred circuits" for regulated power supplies, video amplifiers, detectors, and so on. Although the compilation /8/ is in a preliminary stage, it should be studied by all design engineers.

In all, there are 49 preferred circuits described in this manual. Each is judged on its advantages and disadvantages, and its design principles are given. Among the circuits are d-c regulator circuits, video detectors, limiters, mixers and amplifiers, and multivibrators.

**NEL Circuits.** In a somewhat similar attempt to bring some degree of standardization to the circuit designs originating at their laboratories, the Navy Electronics Laboratory, San Diego, has included several such circuits in its NEL Reliability Design Handbook. Several of these circuits are described in the following pages as examples of the material to be found in the NEL publication.

**Audio-Frequency Voltage Amplifier.** The circuit shown in Figure 5-9 is that of a medium-gain amplifier with good frequency characteristics and low distortion. This amplifier, contributed by R. H. Harwood (NEL), has the following characteristics.

Voltage Gain: 39 db  
 Bandwidth: 10 cps to 40 Kc  $\pm$  1 db  
 Maximum undistorted output:  
 500-kilohm load, 25 volts rms;  
 100-kilohm load, 14 volts rms;  
 both at less than 2 percent intermodulation distortion

Output impedances for conditions of operation are presented in Figure 5-10. Since in some applications it would be undesirable to bypass the output cathode resistor, data have been included for conditions of operations with and without bypassing.

**Radar Video Distribution Amplifier.** In Figure 5-11 is the circuit of a packaged replaceable unit adapted from shipboard use. Contributed by I. L. McNally, it has the following characteristics.

Overall gain: 2 to 1  
 Bandwidth: 60 cps to 6 Mc  $\pm$  3 db  
 Transient response: At 1000 pps with 0.05  $\mu$  sec rise time, will pass with no overshoot 1- $\mu$  sec square-wave pulse with rise time of 0.075  $\mu$  sec

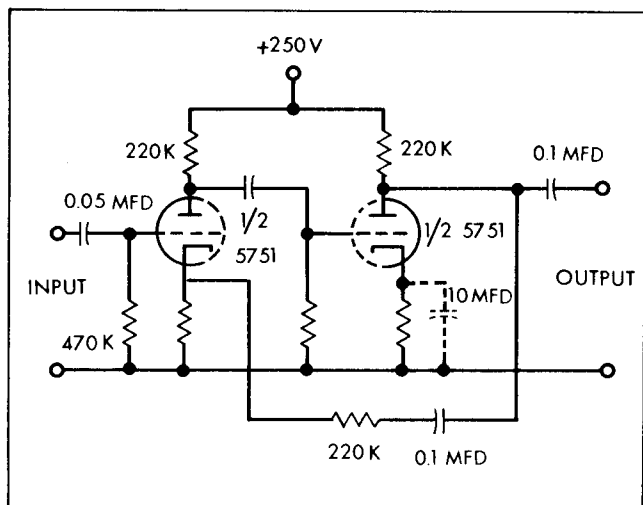

Figure 5-9. Audio-frequency voltage amplifier

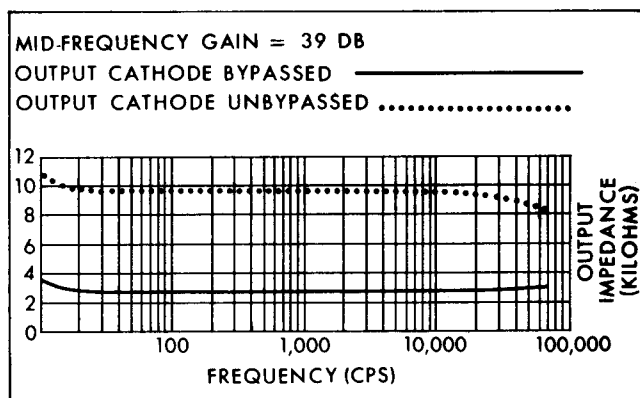

Figure 5-10. Output impedance for audio-frequency voltage amplifier

Input range: 1.5 to 4 volts, positive polarity, from 75 ohms  
 Output: Positive polarity video of sufficient power to drive 20 radar repeaters  
 Power supply: 250 volts at 100 ma, -3 volts dc

**Infinite Impedance Cathode Follower.** Originally intended as a measuring device to read the voltage stored in a capacitor, the circuit in Figure 5-12, from F. C. Martin (NEL), consists of a high-impedance cathode follower directly coupled to a low-impedance cathode follower, and is useful for data storage, data processing, and display applications. Its characteristics are the following.

Input: from -50 to +50 volts  
 Output: any reasonable load; for example, a 1000-ohm per volt meter; output voltage is same as input voltage  
 Response: extends above audio range  
 Input grid current: less than  $10^{-10}$  amp over +50-volt range  
 Discharge rate: with 0.05 mfd storage capacitor, 111 sec per volt

**Regulated Voltage Divider.** The circuit shown in Figure 5-13 is from Bernard (NEL). It utilizes a cathode follower as a low-impedance voltage divider for supplying intermediate voltages from a power supply. The output voltage is controlled by varying  $R_1$ - $R_2$  as by a potentiometer. Best regulation will occur with the highest  $S_m$ , since this produces the lowest output impedance of a cathode follower. This resistance varies from 220 to 48 ohms over the range of 3.3 to 53 ma of output current. The regulation is given in Figure 5-14.

## RADIO-FREQUENCY OSCILLATORS

Although there is a voluminous literature on oscillator stability and means for achieving it, the general principles set forth are still widely disregarded. Therefore, various compensating schemes and gadgets must be provided, such as temperature-compensating

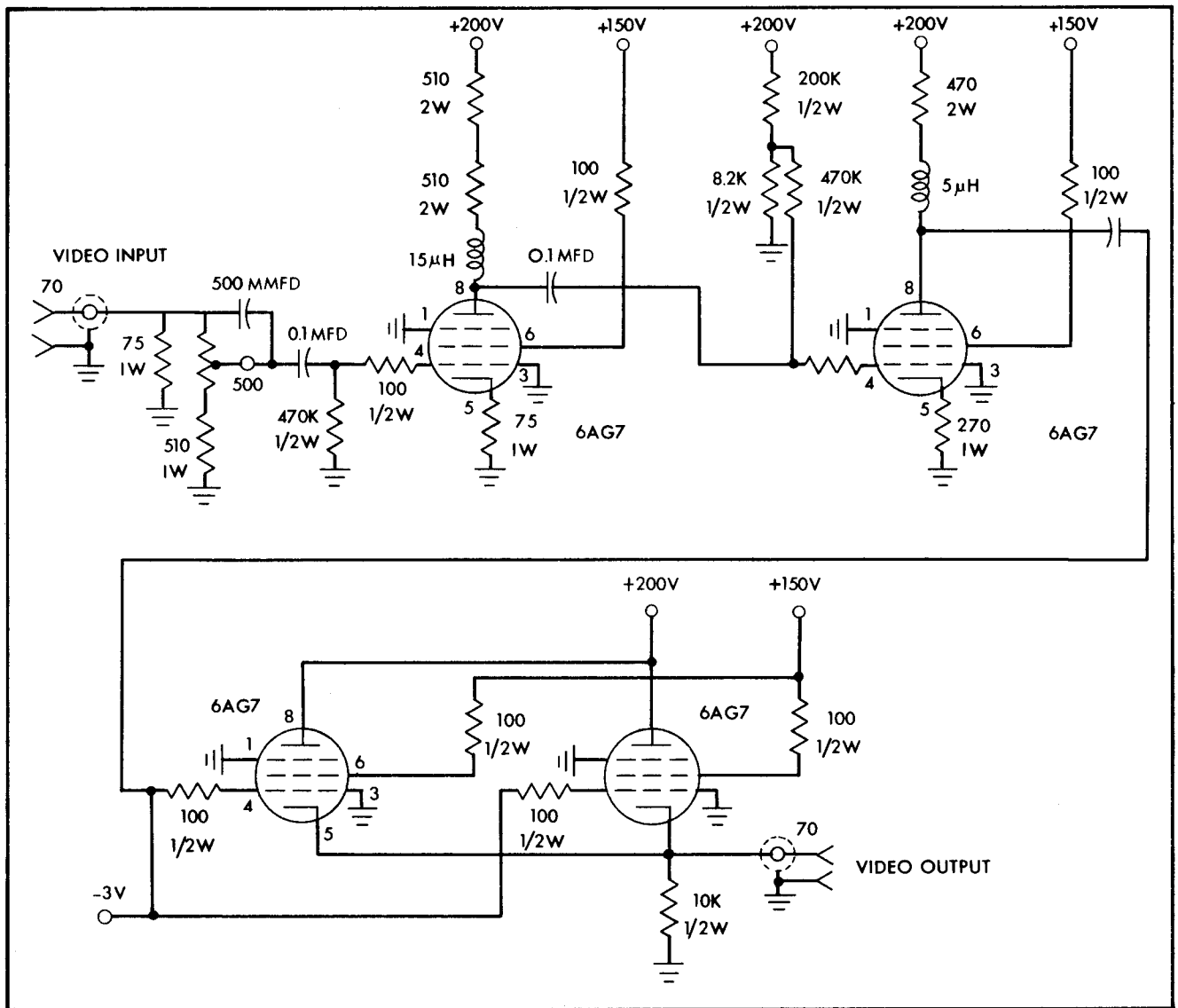

Figure 5-11. Radar video distribution amplifier

capacitors, or complex variable inductances placed within the oscillator coil. It is now possible to design r-f oscillators without having to control the frequency with quartz.

Since the oscillator tube must be placed across some part of the LC circuit in which the oscillations are generated, it follows that variations in tube capacitance affect the frequency of the oscillator. If the tube capacitance is shunted by a very large capacitor, then variations in tube capacitance will produce a much smaller effect. High-C oscillators are well known in the amateur field.

**Clapp Oscillator.** Within recent years, the so-called Clapp, or Gouriet, oscillator has come into wide amateur use because of its remarkable inherent frequency stability. The general circuit is shown in Figure 5-15 and will be seen to consist of a Colpitts

circuit, but with series L and C instead of a parallel arrangement. The tuned circuit looks into large capacitances,  $C_1$  and  $C_2$ , which means that variations in tube capacitance have little effect. In addition, the low impedance presented by these capacitors means that the load on the tuned circuit is very low — the coupling to the tube is weak. In this circuit, the Miller effect is eliminated by using cathode feedback. The input to the tube and the output from the tube are shunted by low reactances, which mask variations in tube impedances.

For maximum stability, this circuit should have as high inductance as possible with maximum possible Q; the tuning capacitor should be as small as possible and still cover the band; the shunt capacitors should be as large as possible and still enable the circuit to oscillate; and the tube should have high  $S_m$ . If the output is taken from the plate circuit of a multigrad

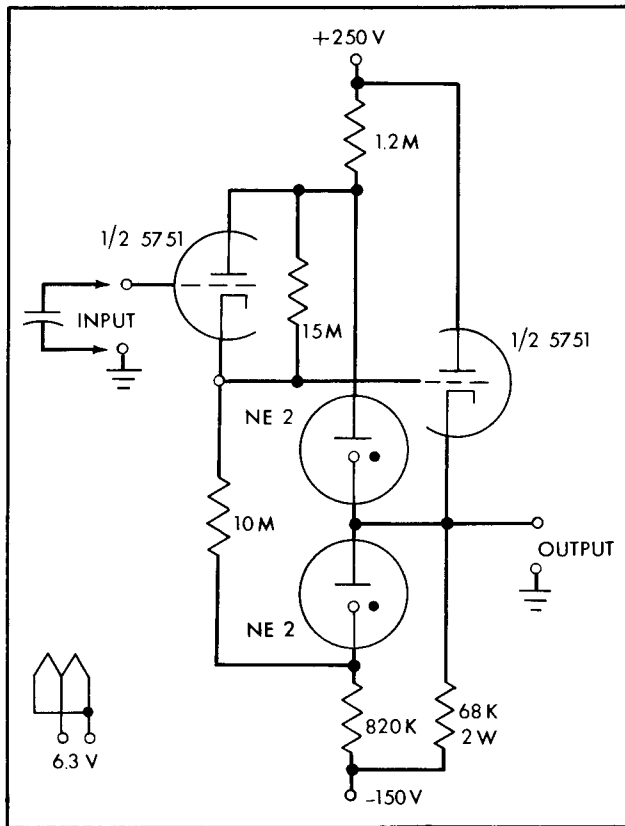

Figure 5-12. Infinite-impedance cathode follower

tube, and if the actual oscillator is made up of cathode,  $G_1$ , and  $G_2$ , additional stability will be obtained, since the load is not directly coupled to the oscillator, but only through the electron stream.

Sandeman reports /9/ an oscillator made for broadcast-band purposes, covering the range 0.7 to 1.4 Mc, using a coil with a  $Q$  of 170, and with  $L$  and  $C$  temperature controlled. This oscillator had the following stability: short-time variation of  $\pm 3$  ppm; long-time variation of  $\pm 10$  ppm; variation with tube change of  $\pm 15$  ppm for an average of 8 tubes; ambient temperature coefficient of 10 ppm for 5 C change.

Oscillator circuits that depend upon tube capacitances are still widely employed and, for obvious reasons, are not in the same class as the Clapp, or Gouriet, oscillator from the standpoint of frequency stability.

Extreme mechanical stability of the tuning capacitor is required in the Clapp, or Gouriet, oscillator. The inductance should be carefully shielded, and no metal should be in its field, because it may warm up and change in dimensions. Since the coupling to the tuned circuit is weak, only low r-f currents flow through the coil, with the result that its dimensions are stable. Arrangements of this fundamental circuit, in which the plate, instead of the cathode, is "hot," can be devised.

General Rules for Attaining Oscillator Stability. Certain ground rules have been established that will produce inherently stable oscillators. Among them are the following.

1. Components and wiring must be mechanically stable.
2. Use tubes with high  $S_m$  and high plate resistance.
3. Keep the inductance and capacitance away from any source of heat. Use a high- $Q$  coil.
4. Keep grid current as low as possible, consistent with stable operation.
5. Keep harmonics as low as possible. Since an oscillator must operate over a non-linear part of the characteristic, some harmonics are inevitable, but low harmonics mean greater frequency stability.
6. A tuned-grid oscillator is less stable than a tuned-plate oscillator for given variations in plate voltage.
7. In circuits employing "ticklers," the feedback inductance should be as small as possible and tightly coupled to the tuned circuit, and all stray capacitances should be small.
8. Maintain voltages constant.
9. Couple the tuned circuit to the tube as lightly as possible, either by tapping the tube across only a part of the circuit, or by using the series-tuned Colpitts circuit with very large coupling capacitances.
10. Use an electron-coupled oscillator because of the removal of the load from the

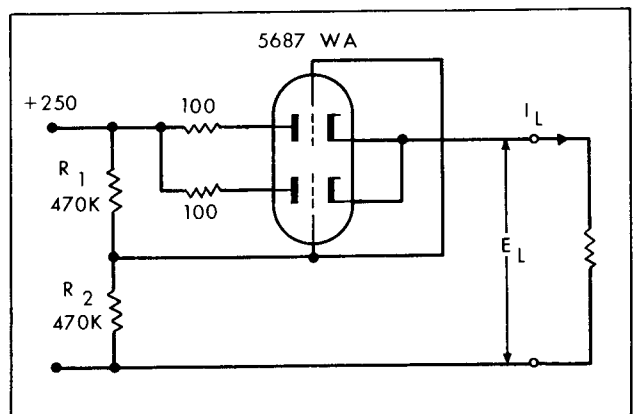

Figure 5-13. Regulated voltage divider



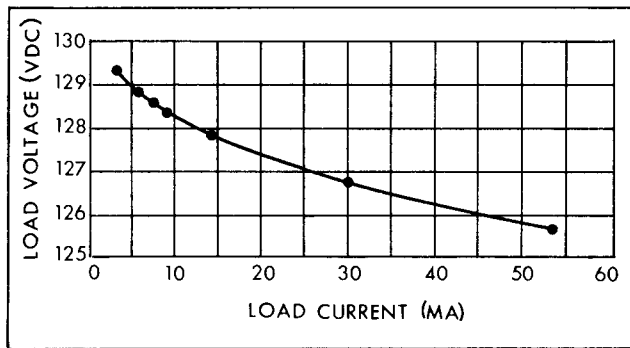

Figure 5-14. Regulation of voltage divider

oscillator proper, and because high-voltage variations have opposite effects in the screen and plate currents.

11. Avoid high-loss dielectrics, because they have high positive temperature coefficients. They should be nonhygroscopic. Choose the tube socket carefully.

The Hartley oscillator is a type of negative feedback circuit; tuned-plate oscillators in general have less harmonic content and larger amplitude, and are more stable to supply voltage variations than the tuned-grid circuit, while the latter has a more uniform output over a given variable frequency range.

Oscillator Frequency Stability Considerations. If the dimensions of the inductance employed in LC oscillators change because of temperature variations, or from other causes, the frequency of the oscillator will change. A typical example is when an oscillator operates at h-f frequencies, or lower, using a solenoid in its circuitry. Changes in the length and diameter of the solenoid, caused by heating, will produce variations in the oscillator frequencies.

Changes in diameter and in length have opposite effects upon the inductance. An increase in length causes a decrease in inductance, while an increase in diameter causes an increase in inductance, as can be seen from the formula for inductance of a solenoid of the shape most often used at h-f frequencies and lower.

$$L = \frac{r^2 N^2}{9 r + 10 \ell}$$

where r = radius of winding in inches  
 $\ell$  = length of winding in inches  
 N = number of turns

Since an increase in the radius produces a greater effect than an increase in length of winding, coil heating will produce a decrease in frequency.

The magnitude of this effect can be estimated by assuming that the axial and radial coefficients of expansion for the copper wire are the same.

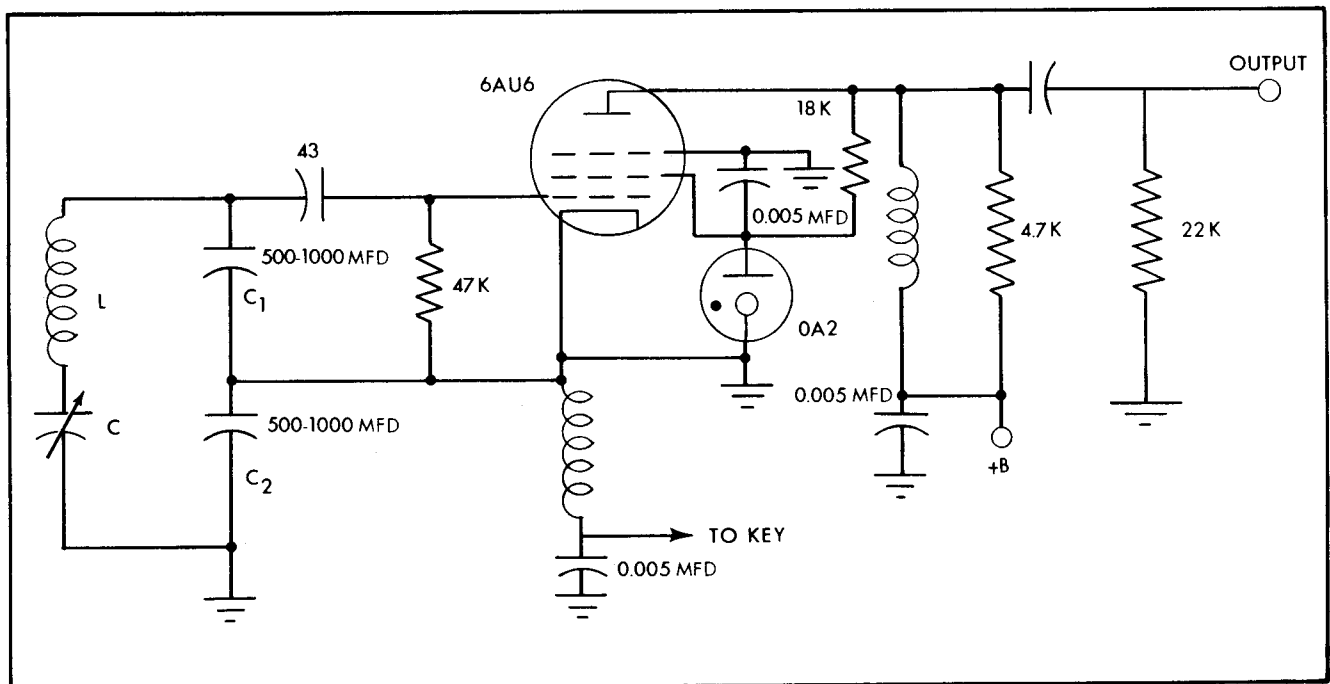

Figure 5-15. Clapp or Gouriet oscillator — a series-tuned Colpitts oscillator

Thus,

$$L + \Delta L = \frac{r^2 N^2}{9 r + 10 \ell} (1 + \alpha t)$$

where  $t$  is the change in temperature  
 $\alpha$  is the coefficient of expansion  
=  $16 \times 10^{-6}$  parts per degree C for copper

In other words, the increase in inductance is directly proportional to the change in temperature multiplied by the coefficient of expansion of the conductor.

The effect in terms of frequency change may be stated as

$$\frac{\Delta f}{f} = \frac{1}{2} \frac{\Delta L}{L}$$

and for a 30 C rise in temperature, the frequency will change 240 cycles per Mc, or 2,400 cycles at 10 Mc.

The inductance, therefore, should not be in the same can as the oscillator tube, and the currents drawn through the coil should be low. Since the effects of the radial and the axial expansions have opposite effects, some opportunity exists for equalizing their respective disturbances on the oscillator frequency.

Moisture. If the air in the insulation of the conductor is displaced by water vapor, because of high humidity, the self-capacitance of the inductor will increase, and the frequency will be lowered. This is due to the fact that the dielectric constant of water vapor is greater than that of air.

Use of Temperature-Compensating Capacitors in LC Tuned Circuits. It is common practice to install temperature-compensating capacitors of the JAN-C-20A type in capacitor-tuned LC circuits subject to temperature change. Some work done by Naval Research Laboratory/11/ indicates that an advantage exists in this process if "the trimmer capacitor has a temperature coefficient of capacitance inversely proportional to its capacitance. Under this condition, the optimum temperature coefficient of capacitance (ppm/°C) is equal to twice the frequency instability (ppm/°C) times the ratio of the total circuit capacitance to the compensating capacitance."

## QUARTZ CRYSTAL OSCILLATOR DESIGN

Quartz crystals continue to be the preeminent means for keeping radio transmitters on their assigned frequencies. In addition, crystals are employed to improve the selectivity of receivers.

Accuracy of Control. Lack of knowledge of what the crystal requires for doing its job effectively, or bad design of circuits to work with the crystal, will make it impossible to attain the accuracy of frequency control or the stability that the quartz plate can provide. The crystal will maintain an oscillator closer to its required frequency than any other

electrical or mechanical device, even if no care is taken in design, but to attain best results, care must be taken.

The accuracy of control and stability are functions of the way the crystal is made, the way it is mounted, and the way it is used in the circuit. The temperature, the circuit reactances, and the amplitude of oscillation all have bearing on stability. For certain circuits and crystals, it is possible to vary the frequency as much as 0.1 percent, and since the required accuracy of control is usually 1/10 to 1/100 of this figure, it is evident that proper design pays off.

It is one thing to measure the controlled frequency of a crystal at a given temperature, in a given circuit, and with a given drive, but it is quite a different matter to jam it into some other circuit at some other temperature or with greater amplitude of oscillation. The two controlled frequencies will not be the same. For example, in the case of a CR-18/U crystal unit, a change of frequency of the order of 0.005 percent may result from a change of 10 percent in the capacitance load into which the crystal works. The overall circuit-plus-crystal frequency tolerance may be as high as 0.01 percent. Closer tolerance can be achieved by trimming the oscillator circuit, but this calls for precision equipment, which may not be available in the field.

Circuit types that give the greatest stability are more complex, give less output voltage, and are not as flexible as less stable circuits.

Much useful data and an excellent bibliography are contained in the Information Bulletin on Quartz Crystals, by C. E. Searles, R. A. Sykes, and I. E. Fair of the Bell Telephone Laboratories, available from the Armed Services Electro Standards Agency, Fort Monmouth, N. J.

Availability of Units. The data in Table 5-2, from the ASES bulletin, provide a guide to presently available units, arranged according to frequency ranges.

Crystal Unit Types. Table 5-3 gives the correlation between the type of crystal element and the commonly-used terms indicating the "cut" of the crystal plate.

## CIRCUIT TYPES

There are three broad types of oscillator circuits employing quartz plates as the stabilizing element.

Parallel Resonant Oscillators. In the Miller (Figure 5-16) and Pierce (Figure 5-17) circuits and derivations from them, the crystal acts as an inductance, and the entire circuit looks like a capacitance and negative resistance in parallel with the crystal. The frequency of operation is the antiresonant frequency of the parallel circuit. These circuits have the lowest stability of the three broad types; unless the circuits are adjusted by means of a monitor, the frequency inaccuracy will be at least 0.002 percent.

Table 5-2. Guide to the selection of the proper crystal unit in appropriate holder

Frequency range (Kc)	Frequency tolerance (%) <sup>1/</sup>	Operating temperature range (° C)	Operable temperature range <sup>2/</sup> (° C)	Load capacitance (mmf)	Crystal unit capacitance (max mmf)	For use in oscillators of		Holder type
						Series resonant type	Parallel resonant type	
16 to 100	±0.012	-40 to +70	---	20.0 ± 0.5	---	---	CR-38/U <sup>3/</sup>	HC-13/U
80.860	±0.010	-30 to +75	---	45.0 ± 1.0	45	---	CR-43/U <sup>3/</sup>	HC-16/U
80 to 200	±0.010	-40 to +70	---	32.0 ± 0.5	---	---	CR-15/U	HC-5/U
	±0.010	-40 to +70	---	---	---	CR-16/U	---	HC-5/U
	±0.002	75 ± 5	-40 to +80	32.0 ± 0.5	---	---	CR-29/U	HC-5/U
	±0.002	75 ± 5	-40 to +80	---	---	CR-30/U	---	HC-5/U
90 to 250	±0.020	-40 to +70	---	20.0 ± 0.5	---	---	CR-37/U <sup>3/</sup>	HC-13/U
	±0.003	75 ± 5	-55 to +85	32.0 ± 0.5	---	---	CR-42/U <sup>3/</sup>	HC-13/U
160 to 330	±0.003	-55 to +75	---	---	See 4/	CR-39/U <sup>3/</sup>	---	HC-15/U
	±0.003	70 ± 5	-55 to +75	---	See 4/	CR-40/U <sup>3/</sup>	---	HC-15/U
200 to 500	±0.010	-40 to +70	---	---	---	CR-25/U	---	HC-6/U
	±0.002	75 ± 5	-40 to +80	---	---	CR-26/U	---	HC-6/U
	±0.010	-40 to +70	---	20.0 ± 0.5	---	---	CR-46/U <sup>3/</sup>	HC-6/U
	±0.002	75 ± 5	-40 to +80	20.0 ± 0.5	---	---	CR-47/U <sup>3/</sup>	HC-6/U
455	±0.020	-40 to +70	---	---	7.5	CR-45/U <sup>3/</sup>	---	HC-6/U
800 to 3,000	±0.0075	-55 to +90	---	32.0 ± 0.5	7.0	---	CR-48/U <sup>3/</sup>	HC-6/U
800 to 15,000	±0.002	75 ± 5	-55 to +90	32.0 ± 0.5	7.0	---	CR-27/U	HC-6/U
	±0.002	85 ± 5	-55 to +90	32.0 ± 0.5	7.0	---	CR-36/U	HC-6/U
800 to 16,000	±0.005	-55 to +90	---	32.0 ± 0.5	7.0	---	CR-18/U	HC-6/U
800 to 20,000	±0.005	-55 to +90	---	---	7.0	CR-19/U	---	HC-6/U
	±0.002	75 ± 5	-55 to +90	---	7.0	CR-28/U	---	HC-6/U
	±0.002	85 ± 5	-55 to +90	---	7.0	CR-35/U	---	HC-6/U
10,000 to 25,000	±0.005	-55 to +90	---	32.0 ± 0.5	12.0	---	CR-33/U <sup>3/</sup>	HC-6/U
10,000 to 75,000	±0.005	-55 to +90	---	---	7.0	CR-23/U	---	HC-6/U
	±0.002	75 ± 5	-55 to +90	---	7.0	CR-32/U	---	HC-6/U
15,000 to 20,000	±0.002	85 ± 5	-55 to +90	32.0 ± 0.5	7.0	---	CR-44/U <sup>3/</sup>	HC-6/U
15,000 to 50,000	±0.005	-55 to +90	---	---	7.0	CR-24/U	---	HC-10/U

<sup>1/</sup> In addition, 0.002 percent crystal units shall not deviate more than 0.0005 percent from the frequency value measured at the midpoint of the operating temperature range, when measured over the operating temperature range.

<sup>2/</sup> The operable temperature range is defined as the temperature range over which the crystal unit will oscillate but not necessarily within the frequency tolerance.

<sup>3/</sup> Special Application type (limited production).

<sup>4/</sup> Crystal unit capacitance shall be determined from formulae contained in Standards MS91393 and MS91394 for the CR-39/U and CR-40/U, respectively.

Table 5-3. Crystal Characteristics

Designation	Mode of motion	Crystal cut	Frequency (Kc per mm)
A Element	Thickness shear	AT-cut	1660/t
B Element	Thickness shear	BT-cut	2560/t
C Element	Face shear	CT-cut	3070/w
D Element	Face shear	DT-cut	2070/w
E Element	Extensional	+5° X-cut	(2600 to 2760)/ℓ
F Element	Extensional	-18° X-cut	(2540) ℓ
G Element	Extensional	GT-cut	3370/1 at w/ℓ = 0.86 (zero temp coeff)
H Element	ℓ-w flexure	+5° X-cut	(4400 to 5200) w/ℓ <sup>2</sup>
J Element	ℓ-w flexure	Duplex	(5500 to 5600) w/ℓ <sup>2</sup>
M Element	Extensional	MT-cut	(2500 to 2700) ℓ
N Element	ℓ-w flexure	NT-cut	(5000 to 5700) w/t <sup>2</sup>

Where t = thickness  
w = width  
ℓ = length

The Pierce circuit is most often used, since no tuning is required. Neither the Miller nor the Pierce circuit will oscillate when the crystal is removed or broken.

**Series-Resonant Oscillators.** Greater stability may be secured from series-resonant circuits in which the crystal acts as a resistance and the frequency of oscillation is the resonant frequency of the crystal. A minimum error of 0.0005 percent may be expected. More components are required than with the simpler parallel-resonant types, the components must be tuned mutually, and in most cases they do not permit grounding one terminal of the crystal. The load the crystal looks into must be purely resistive. Since the crystal resistance is in the feedback path of the oscillator, the lower the crystal resistance the greater will be the circuit

gain. Several circuits of the series type are shown in Figure 5-18.

In Figure 5-18(e), the crystal must be resistive when LC tank is tuned to the crystal frequency. Since the antiresonant resistance of the crystal is too high for the circuit to oscillate, oscillations occur only at the resonant frequency  $f_r$  of the crystal unit.

**Series-Circuit Design.** The frequency of oscillation can be controlled to a small extent by tuning the LC circuit, but maximum output voltage is obtained when the circuit is tuned to the exact resonant crystal frequency. A variable capacitor in series with the crystal will raise the frequency; an inductance in series with the crystal will lower

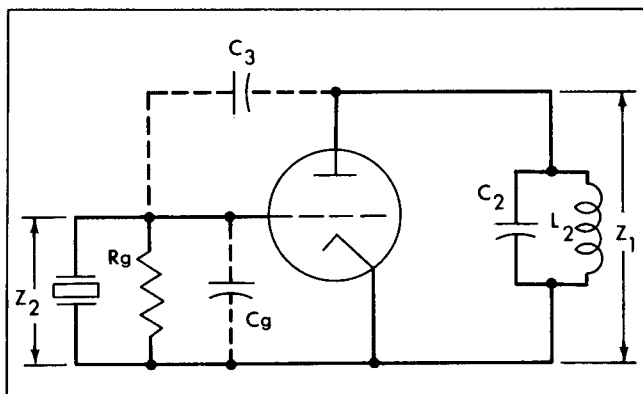

Figure 5-16. Miller oscillator

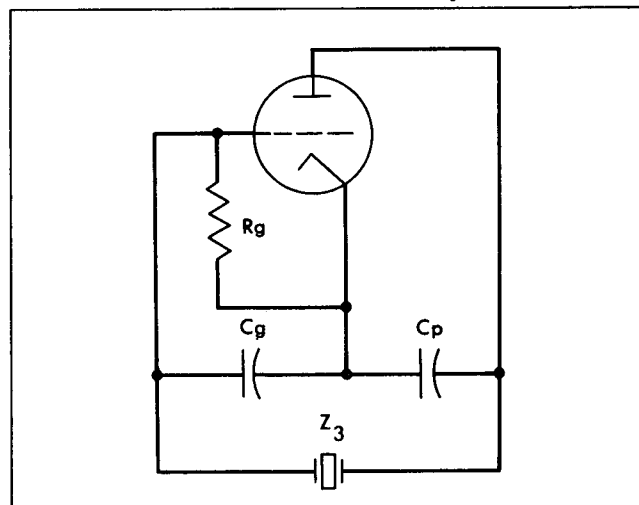
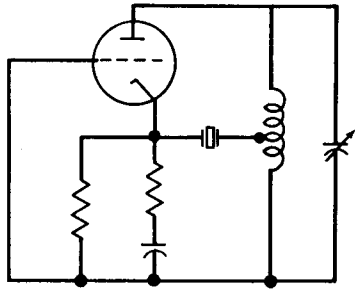
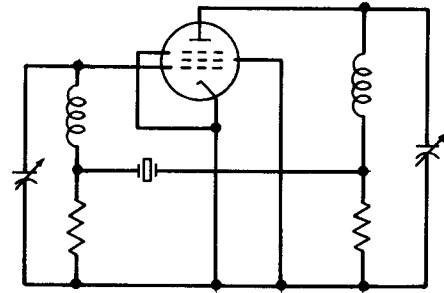

Figure 5-17. Pierce oscillator



(A)



(B)

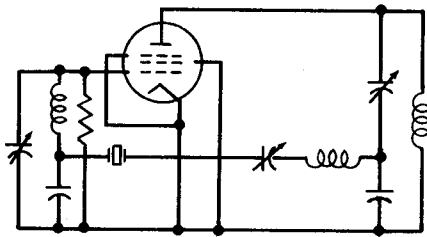

(C)

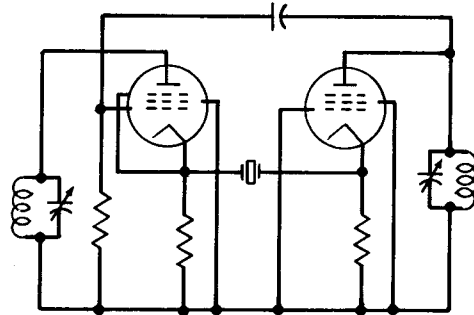

(D)

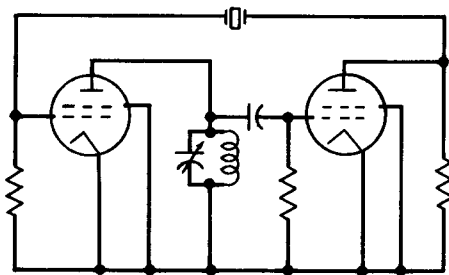

(E)

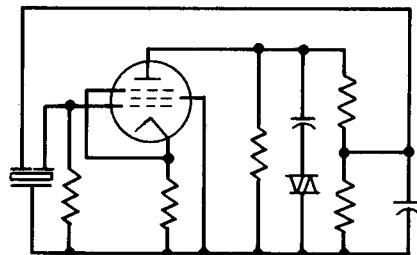

(F)

Figure 5-18. Elementary oscillators of the series-resonant type

the frequency, so that exact frequency adjustment will, in this case, require the use of a coil and a variable condenser.

Voltage amplitude increases as the crystal resistance decreases or as the crystal terminating impedances are raised. Maximum stability is obtained when the crystal terminating impedances are as low as circuit gain will permit. Too much stray capacitance across the crystal will permit the circuit to oscillate when the crystal is removed.

Figure 5-18(a) is the simplest of the series circuits, and delivers high output when used with power tubes. For more information, the reader is referred to Buttler. /12/

Figure 5-18(b) permits a wide range of crystal resistances and may have low harmonic output because of the filtering action of the two tuned circuits. /13/

Circuit Figure 5-18(c) has a capacitance termination and eliminates the phase shift error caused by stray capacitances across terminating resistances.

Circuit Figure 5-18(d) has a single tuning adjustment (f) and means for taking out harmonic voltages (nf). Crystal resistances lower than 1,000 ohms are required. This is a cathode-coupled circuit. /14/

Figure 5-18(e) is suitable for high-resistance crystals. /15/

Figure 5-18(f) is used with low-frequency crystals that have a divided electrode. /2/ A varistor in the plate circuit limits the crystal current; some frequency adjustment is possible by placing a reactance in the crystal lead to ground.

Bridge-Type Oscillators. For greatest frequency stability, bridge-type circuits are employed, in which the crystal forms one arm of the bridge. Another arm of the bridge is a tungsten lamp, which automatically limits the crystal voltage amplitude. The stability with such circuits is usually better than 0.0001 percent, and for this reason, these circuits are employed in frequency standards. The Meacham circuit, /16/ Figure 5-19(a), is probably the most stable oscillator yet devised. Figure 5-19(b) is similar, with the advantage of having a single tuned circuit, but since the tube impedances shunt the bridge arms, the stability may not be as great as with the Meacham circuit. /17/

VHF Oscillators. For frequencies higher than about 20 Mc, an overtone mode of the crystal is generally used. This is because of the difficulty of grinding very thin plates and the danger of damage to the plates. Crystal Q must be very high to operate in an overtone mode in parallel-resonant oscillators, and for this reason, such circuits are used for frequencies below 20 Mc.

The circuits in Figure 5-20(a) to (d), inclusive, will operate up to 50 or 75 Mc, the limitation being the

stray capacitances across the crystal and terminating resistances. Capacitance-bridge circuits in which the crystal forms one arm of the bridge /18/ oscillate well up to 200 Mc, but require a balanced bridge and two tuning adjustments.

Crystal Stability. The effects of the various circuit reactances and their changes upon the stability of a crystal-controlled oscillator are important and are discussed in the ASEA bulletin. After these are taken into account, however, the crystal unit itself may suffer some frequency changes. They are due to:

1. Temperature change
2. Rapid temperature gradient or crystal strain
3. Too high current amplitude through the crystal
4. Aging of the crystal
5. Mounting changes
6. Contamination of the holder.

Regenerative Miller Oscillator. In a study /19/ to investigate series and parallel-resonant oscillators for use with AN/ARC-22 equipment in the region of 20 to 50 Mc, conventional Miller, Colpitts, Hartley, Pierce, and cathode-coupled circuits were examined. The circuit that best met the needs is shown in Figure 5-21, which is a Miller circuit with regenerative feedback. Miniature tubes, Type 5718, and CR-23/U crystal units were employed.

Drive levels under 1 milliwatt and output voltages of about 6 volts were obtained. Stability with plate voltage changes was approximately 1 part per million per 10 percent change in  $E_p$ . A 1-mmfd change in plate tuning capacitance produced a frequency change of from 1.5 to 10 parts per million. Higher output was obtained with lower resistance crystals, which were in the range from 27 to 51 ohms.

Oscillations not controlled by the crystal were experienced, but not if the feedback capacitor and crystal load (input capacitance) were correct. Thus, with a 20-mmfd feedback capacitor, and with the plate tank loaded with 4,700 ohms, oscillation occurred only when the crystal load was greater than 25 mmfd. With a 20-mmfd crystal load, oscillation did not occur unless the feedback capacitor was larger than 25 mmfd or the plate voltage was increased from 100 to 125 volts.

In this study, data showing output, stability, and other useful data were secured for several practical circuits. The curves shown in the report are useful for design purposes, since they give the variations in output, drive, and frequency as the circuit constants are varied.

AFC Applied to Crystal-Controlled Oscillators. The following notes on this subject are taken

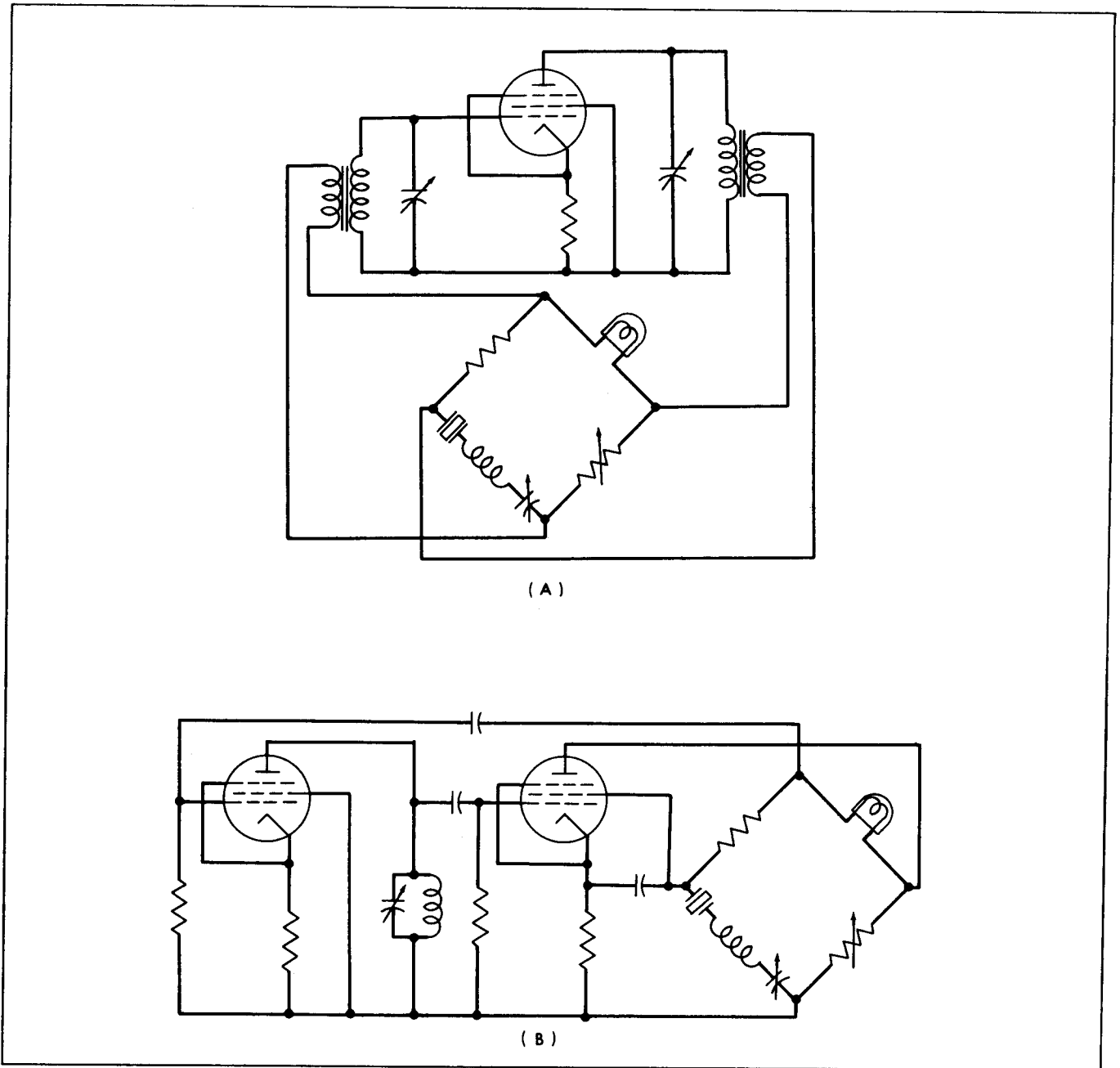

Figure 5-19. Elementary oscillators of the precision bridge type

from Clark./20/ If the maximum amount of tuning range is required, choose a fundamental mode type of crystal and oscillator. If multiplication of the oscillator frequency is desired, and if spurious injection must be kept at a minimum, choose a 3rd- or 5th-overtone oscillator and multiply less.

A fundamental mode oscillator should be correlated at either the 32-mmfd point (CR-18/U or the series mode point CR-19/U). The series mode point is a wise choice, because the high circuit shunt

capacitance used with the CR-18/U crystal does not permit good afc action. Overtone crystal oscillator circuits are usually correlated at the harmonic series mode point (CR-23/U or CR-32/U). This choice of possible correlation points means that any crystal made to the correct military specifications can be used.

To shift the frequency, a reactance-tube circuit may be employed to change the effective capacitance  $C_0$ , which represents the holder capacitance

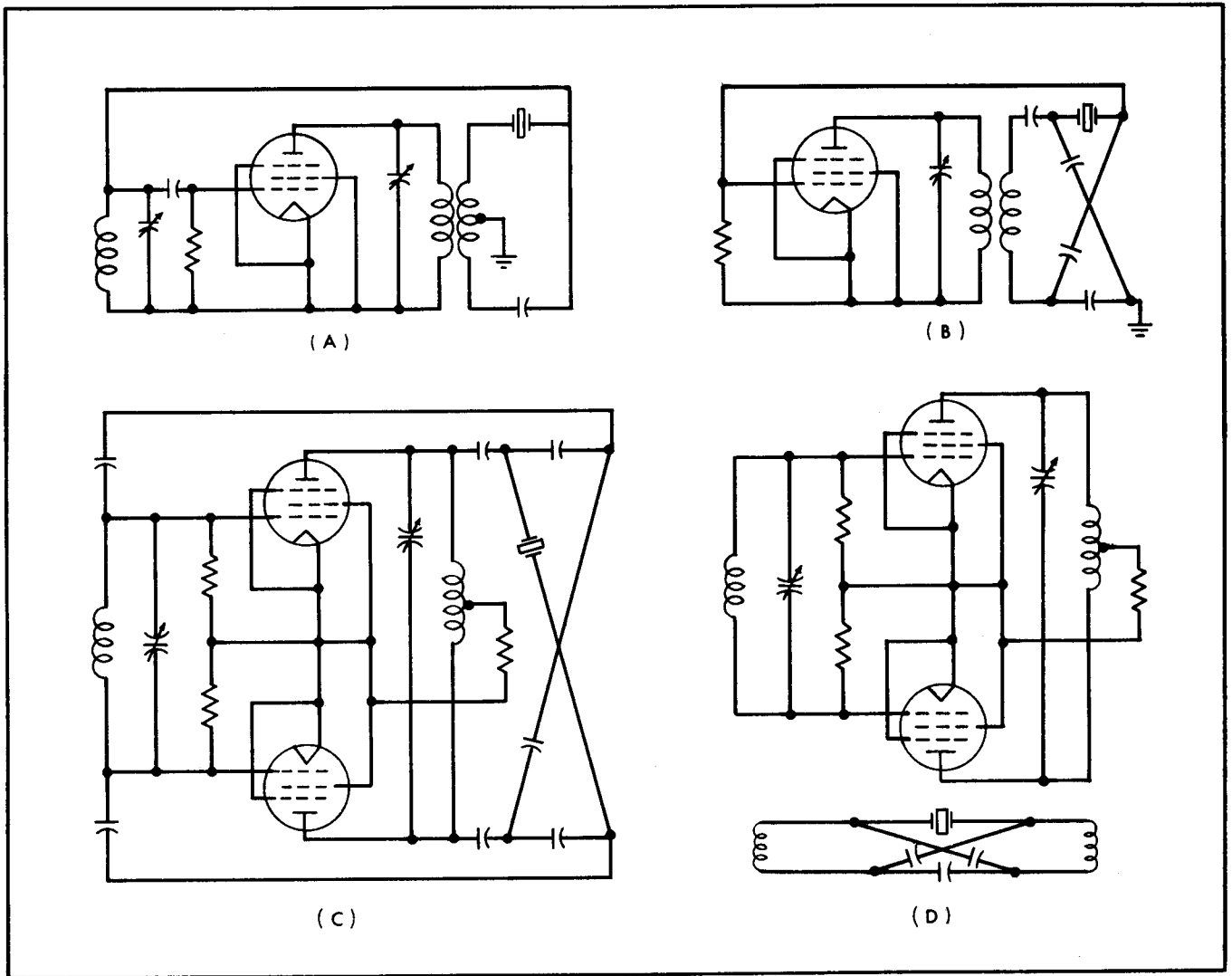

Figure 5-20. Elementary oscillators of the capacitance-bridge type, for very high frequencies

and the capacitance across the crystal. Another system is to use a saturable reactor, which will represent a variable inductance, that may be coupled to the actual oscillator circuit. Another method (see Figure 5-22) cited by Clark involves a biased diode and a capacitor. This works very well, if temperature stability of the control circuit is not too important a consideration.

During the positive half cycle, with zero bias, the diode conducts and effectively inserts a small resistance in series with the capacitor. On the negative half cycle, the diode is nonconducting, and the capacitor is effectively not connected in the circuit. By changing the control bias, the change in the conducting time of the diode changes the effective capacitance. This capacitance change, when properly linked to a sensitive point in the oscillator circuit, can be made to vary the oscillator frequency in accordance with the change in control bias.

Mechanical methods of shifting frequency are not recommended because of poor performance under conditions of heavy vibration.

All of the controlling circuits mentioned, except the mechanical system, add low-Q circuit loading to the oscillator. This causes reduced operating efficiency, because it is necessary to increase the power input to the oscillator to deliver the same power output to the multiplier stages. The loading effect is an important consideration in crystal life, since this affects the necessary power dissipation in the crystal.

#### NOTES ON PROPER TUBE APPLICATION

Certain factors inherent in tube operation are often taken for granted by circuit designers, or their effects on circuit operation are overlooked. Among these factors are grid emission, heater-cathode leakage, contact potential, and peak a-c voltages and currents. Some of them are discussed below in material from Kelly./21/



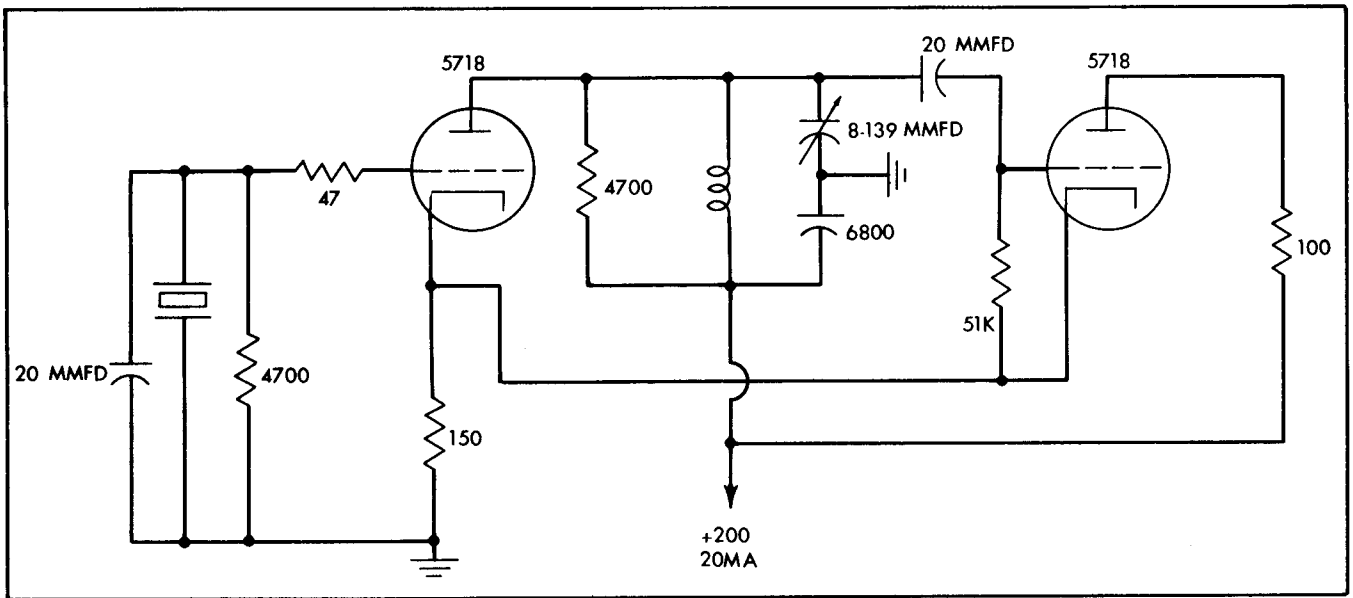

Figure 5-21. Regenerative feedback Miller oscillator

**Rectifier Operation.** Rectifier tubes are supposed to be operated within certain maximum limits of d-c output current, peak inverse plate voltage, and peak plate current. The first two factors are easily measured or calculated, but the third requires an oscillograph. It is often neglected entirely in circuit design. Many rectifiers fail because of this neglect, even though d-c output current and peak inverse voltages are well within manufacturers' ratings.

Where the designer is forced to get the required output current and voltage in the most efficient manner, he prefers a power transformer of low leakage reactance and with plenty of copper to keep the heat down. Then he uses a capacitor-input filter, with the result that peak currents through the tube may exceed by a wide margin the manufacturer's rating, because the plate-supply impedance is too low to limit these peak currents.

Thus, a 5Y3 with an rms plate-to-plate supply voltage of 700 and a 10-mfd capacitor as input to the filter requires a minimum of 50 ohms "effective plate-supply impedance per plate"; with 1,000 volts rms applied, the manufacturer recommends a minimum of 140 ohms per plate, and under either condition states that if higher values of input capacitance are employed, the effective plate supply impedance may have to be increased to limit the peak plate current to the desired value.

A transformer of low efficiency and poor power-supply regulation may have to be tolerated under these conditions, and these disadvantages must be weighed against longer life for the rectifier tube.

The plate supply impedance per plate (for full-wave rectification) may be found from

$$R \cong N^2 R_{pri} + R_{sec}$$

where N = the no-load voltage ratio of the transformer

$$= \frac{\text{(half) secondary voltage}}{\text{primary voltage}} \quad \text{at no load}$$

$R_{pri}$  = resistance of primary winding in ohms

$R_{sec}$  = resistance of (half) secondary winding in ohms

If this value of the impedance is too low to limit the peak plate current to the rated value, two equal resistances should be inserted at the plate terminal of the tube.

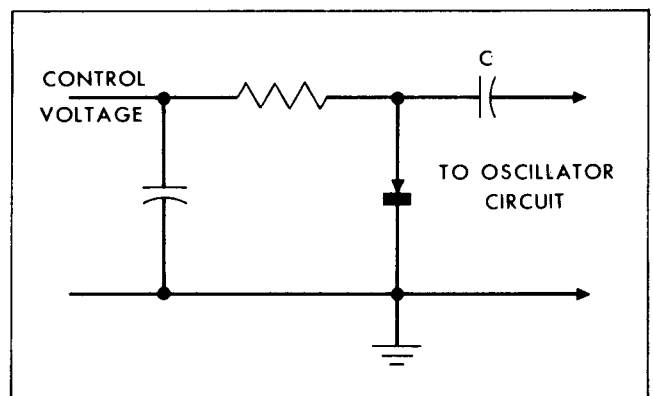

Figure 5-22. Method of shifting frequency by using a biased diode and capacitor

Contact Potential.<sup>21/</sup> This factor has the effect of a small voltage in the grid-cathode circuit. It is a function of cathode temperature and, therefore, is a function of heater voltage, and varies with the life of the tube. Its deleterious effects are felt when a tube operates with a low value of bias — say one volt or less — as may be secured by using a low value of cathode resistor for the purpose of getting high gain. The contact potential, under these conditions, may nullify the cathode bias applied to the tube, with the result that the tube actually has no bias, or it may be even operated at a slightly positive bias. If grid current flows, the input circuit is loaded, and the end point may be less gain than if the tube had been operated with a higher bias and lower  $S_m$ . Additional information can be found in the chapter on Component Parts.

Grid Emission. The tendency to use the highest possible value of grid circuit resistance to get high gain may lead to trouble due to grid emission. If the grid emits, its current flowing through the resistance of the input circuit or the grid resistor will produce a voltage of a polarity opposite that of the bias produced by normal current flowing through a cathode resistor. Bias may be lost, and circuit gain may increase to such an extent that a plate current runaway condition may result.

For maximum reliability, the grid resistance should be as low as gain conditions permit.

Another form of grid emission must be considered with in applications in which the grid is driven positive. This is secondary emission caused by bombardment of the grid during the positive excursion. While most of the electrons so emitted will return to the grid, others will go to the plate or other positive electrodes. Flow of secondary electrons from the grid is against the normal flow of electrons to the grid from the cathode during positive grid drive, and as a result, there is less current in the grid circuit than if secondary emission did not exist.

The effect of grid secondary emission is to make the tube easier to drive. If just enough drive is provided by the designer to develop the required power output, substitution of a new tube, with less active grid, may result in insufficient drive and low power output. The remedy and prevention of this kind of difficulty is to provide an excess of driving voltage.

Another effect may be caused by secondary emission. In Figure 5-23 is a typical circuit in which the grid is driven positive. The dotted curve is the normal diode characteristic of the grid and the solid curve shows the effect of secondary emission in giving the characteristic a negative slope. If a signal that drives the grid past point B is applied, the intersection of the grid load line with the grid current curve, the tube will block at point B and the grid will remain at the potential of this point when the signal is removed. To prevent this condition, see that the grid is not driven into the negative-current region.

Heater-Cathode Leakage. Fixed bias or grid-leak bias or an actual bias voltage of 40 to 50

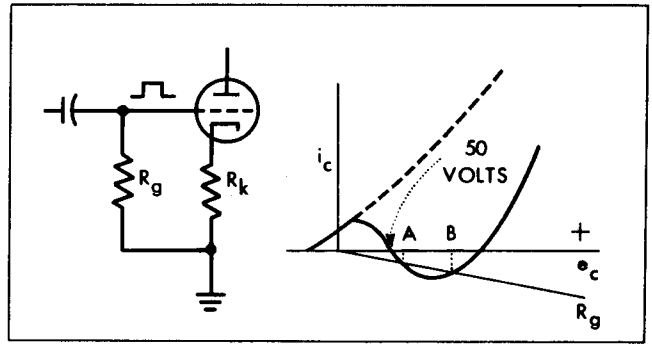

Figure 5-23. Grid circuit pulsed in a positive direction

volts between heater and cathode will eliminate trouble from this source. The latter expedient is required where an unbypassed cathode is necessary or where there must be complete freedom from heater-cathode leakage effects. A large bypass capacitor across the cathode resistor will reduce the effect of leakage currents. In Figure 5-24 is a typical heater-cathode leakage characteristic. If operation is at or near zero between heater and cathode, any small voltage variation in  $E_{hk}$  produces a large change in  $I_{hk}$ . This method is often used to reduce hum in high-quality amplifiers.

Gas-Filled Rectifier Operation. Since a gaseous rectifier tube will supply current in excess of circuit requirements, care must be taken to limit this current to safe values. When two or more tubes are operated in parallel, some means must be provided for equalizing the current furnished by each tube. A resistance in series with the plate, and with the filaments in parallel across the same source of supply, is the usual method. An increase in tube voltage drop is the most useful sign of end of life.<sup>22/</sup>

In rectifier or inverter circuits, in which the tubes supply power to highly inductive loads, tube life

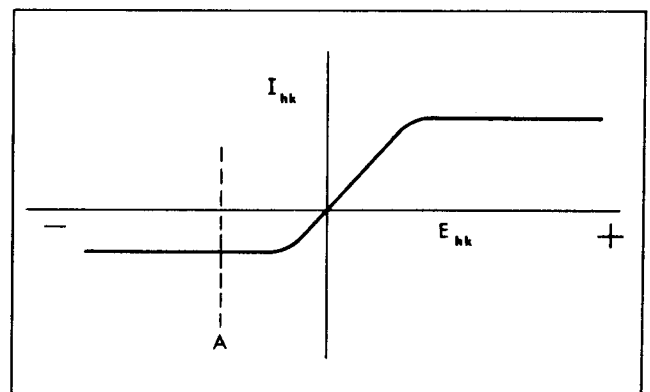

Figure 5-24. Typical heater-cathode leakage characteristic

will be decreased, unless care is exercised in design to limit the rise of inverse plate voltage. If a thyatron is controlled by grid control, the inverse plate voltage with inductive loads may rise at a very rapid rate, and tube life will be reduced. This is caused by the sputtering of anode material from the impact of residual positive ions attracted to the negative anode at high velocity, with consequent gas cleanup. A high rate of rise of initial inverse voltage may cause arcbbacks, because of insufficient de-ionization current.

By a "cushioning" arrangement consisting of a capacitor and resistor in series and connected across the tube, the rise of initial inverse voltage is delayed and the rate of rise is reduced. Thyratrons, which normally fail in 200 or 300 hours, will give satisfactory service for many thousands of hours by this method./23/

Frequently, a premature or delayed operation of a thyatron is erroneously attributed to tube instability rather than to other circuit elements or design. A typical example is a circuit in which plate and control grid were connected to different sections of a stepping gang switch. When voltage was applied at +B, leakage between the terminals of the switch caused the tube to fire. An extra tube to isolate the connections between the gang switch eliminated the trouble.

Other material on extending tube life will be found in the bibliography at the end of the chapter.

"Starvation Circuits." Under this general term, Erdle /24/ includes the techniques of operating tubes with reduced heater voltage, operation on the tail of the plate current-grid voltage curve near cutoff, and operation with low plate voltage on triodes and low screen voltage on pentodes. Each has serious drawbacks. They are reviewed briefly here.

**Reduced Heater Voltage.** Figure 5-25 shows the relation between plate current and heater voltage for a fixed set of plate supply and grid voltages, and fixed load resistance. Curve 1 may be taken as depicting an average tube, while curves 2 and 3 are for extreme cases that might be encountered among tubes that have acceptable characteristics at rated voltage. To the left of the knee, the current becomes temperature-limited, while to the right, it is space-charge-limited. Slight changes in heater voltage, or variations among tubes at a constant low heater voltage, can result in large variations in position with respect to the knee of the curve.

When a tube is operated in the space-charge-limited region, the control grid has maximum effectiveness, and  $S_m$  and the other electrical characteristics will be near their rated values. When operation is completely in the temperature-limited region, all the cathode emission is collected by the plate, regardless of grid signal, and the grid has practically no effect, so that  $S_m$  drops essentially to zero.

Variations in the plate-current characteristics among tubes can result in some of them operating in

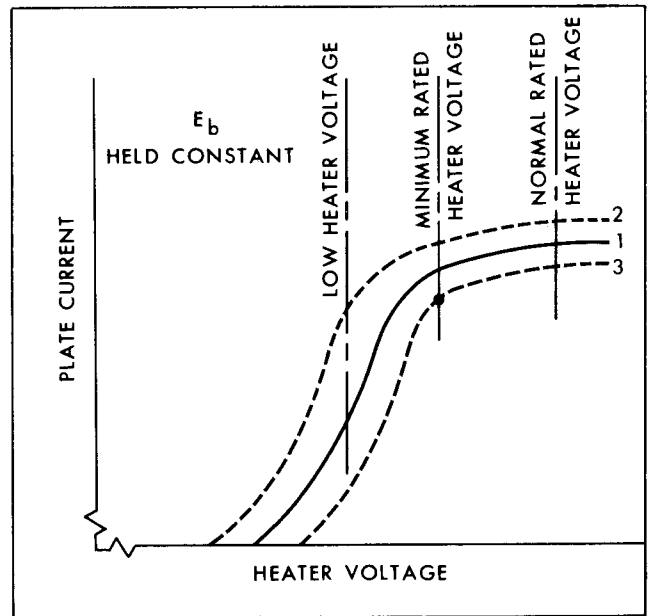

Figure 5-25. Typical curve of plate current for various values of heater voltage

the space-charge-limited region, others at various points along the knee of the curve, and still others in the temperature-limited region. The mutual conductance can vary all the way from its rated value to zero, even though the tubes are all within specified limits at normal heater voltage.

Thus, in terms of circuit performance, one or several of a small group of tubes may function satisfactorily in a circuit with reduced heater voltage. However, when this circuit is employed where large quantities of tubes are used, the full effects of the variations in tube characteristics at low heater voltage will be felt. Since many tubes that meet all of the tube manufacturer's specifications would not function properly in applications with reduced heater voltage, a selection or sorting program would probably be necessary. The entire problem would be further compounded if tubes from different manufacturers were used.

Furthermore, at reduced heater voltages, when a tube is operated on or near the knee of curve 1, Figure 5-25, a small variation in heater voltage can result in large variations in  $S_m$  and other electrical characteristics. Thus, the performance of any given tube will be erratic because of fluctuations in heater voltage.

As the tube ages, plate current naturally decreases with fixed plate voltage. Therefore, a tube operated at low heater voltage may "fail" in a given circuit much sooner than if it were operated at normal rated heater voltage and temperature.

In applications that involve pulse operation, such as gating, the cathode may be incapable of supplying the required peak currents at reduced heater voltage. Continuous operation in this manner for an appreciable length of time will usually result in rapid failure.

Operation Near Cutoff. /24/ In the load characteristic of most tubes, there are usually two nearly linear regions, as shown in Figure 5-26. Region A is the one commonly employed for conventional operation. In the tail of the curve, the current drain is low. Operation in this region provides another method of accomplishing the starvation principle.

Figure 5-26 also shows the relation between vibrational noise output and bias voltage under the condition of constant signal output for a transducer. It is seen that the vibrational noise output will be increased radically by the use of starvation designs. Even in equipment operated under conditions that do not include mechanical vibration, the curves of Figure 5-26 are applicable. Vibrational noise output is closely akin to microphonism, and the curves could be considered as an indication of the microphonic properties of the tube as a function of bias voltage.

Instability is another trouble that arises from operation on the tail of the characteristic. In Figure 5-27 are shown the curves of plate resistance and plate current for three values of heater voltage in a triode. Fixed-bias operation is the extreme condition for instability at any operating point, and the following discussion will be made on that basis. Fixed bias can be represented by a vertical line. Two bias points are shown, one for operation in region B and the other for region A. Note that with deviations in heater voltage alone, extremely wide variations in plate resistance are encountered for operation in region B. At normal operation, however, these variations are much smaller. In some circuits, another tube characteristic may be more critical than  $r_p$ , but variations of this characteristic are a strong indication of variations in others as well.

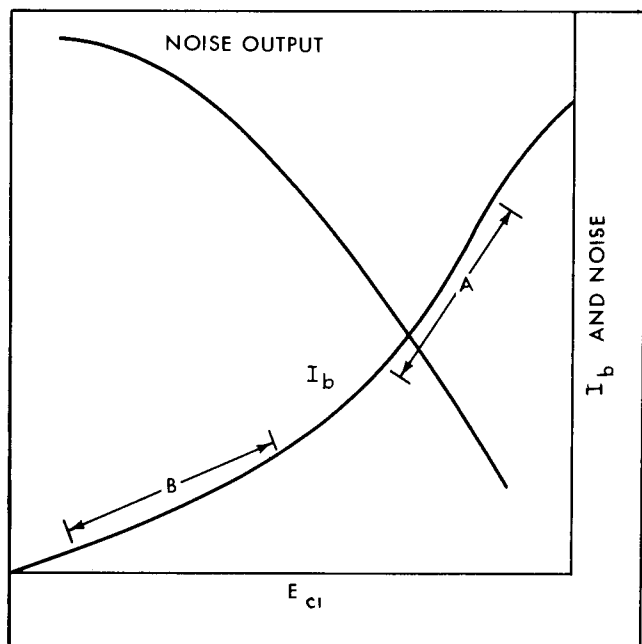

Figure 5-26. Average plate current-grid voltage characteristics

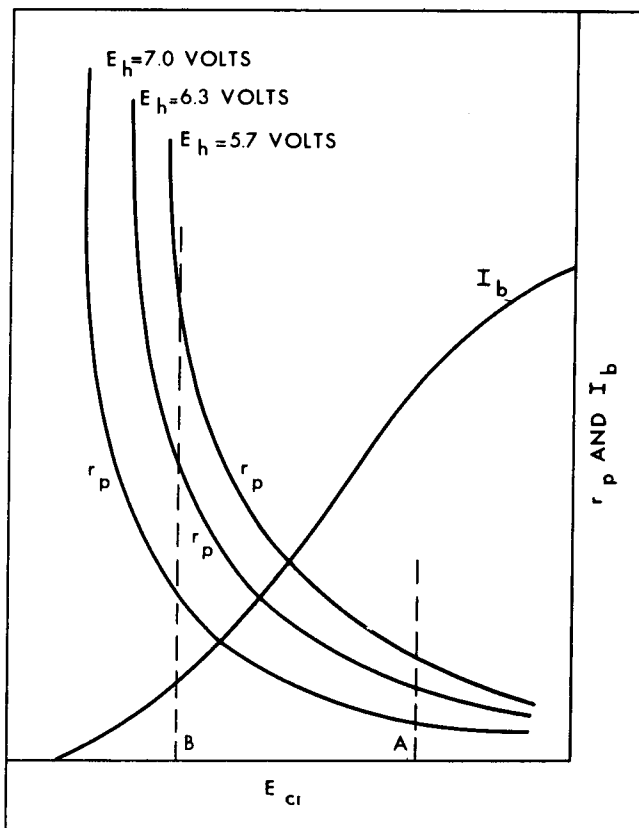

Figure 5-27. Effects of heater voltage variations on plate resistance

Operation with Low Plate Voltage. Figure 5-28(a) shows the  $E_{C1} - I_p$  curve for a triode with no plate load resistance, with a normal plate supply voltage. It is typical of the curve data usually published by tube manufacturers. Figure 5-28(b) shows the effect of a very low value of plate supply voltage and low plate load resistance. The dotted lines on both figures indicate the deviations that can be encountered among a large group of tubes. The large variations in characteristics encountered with very low plate supply voltage and low d-c load resistance result from the operation of the tubes in a region that is not normally controlled in production by the manufacturers, and which would be both difficult and very expensive to control. The wide variation of characteristics with low plate supply voltage and low d-c load resistance could result in considerable difficulty in equipment production. Selection or sorting programs would probably become necessary in most cases, and it follows that the replacement problem would similarly involve selection.

Figure 5-28(c) shows the characteristic of a tube operating with high plate supply voltage and high d-c load resistance. Of all the starvation circuits, this is by far the least critical. The only serious drawback to this type of operation is a limitation on the applied grid voltage swing. A tube with a characteristic below average will tend to cut off at a lower grid bias than one with a characteristic above average.

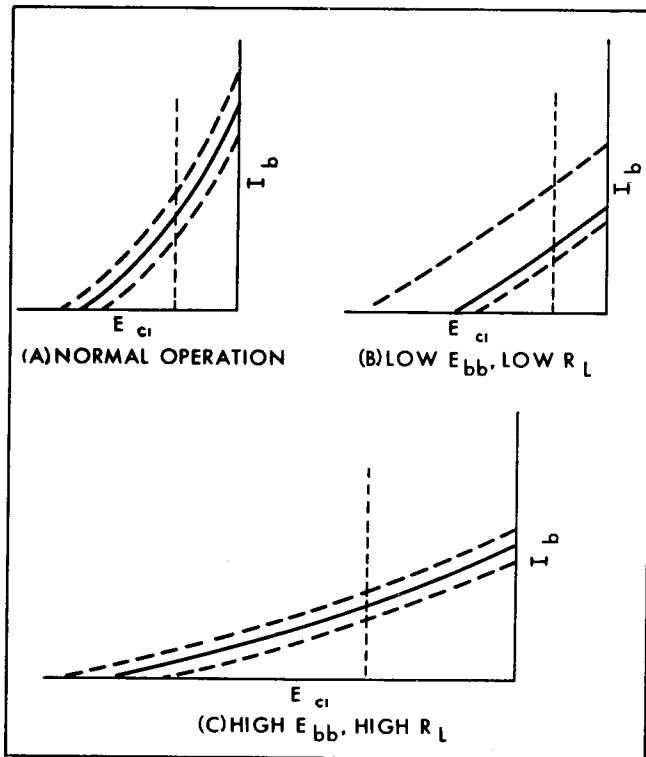

Figure 5-28. Variations in plate current for different values of supply voltage and load resistance — dotted lines represent variations among individual tubes

If this fact is not taken into account, the below-average tubes may exhibit considerable distortion when driven beyond cutoff.

**Starvation-Circuit Disadvantages.** Operation of the tube on the tail of the transfer curve has these effects: the vibrational noise output will increase drastically, the microphonic tendencies will be considerably increased, and instability will be encountered, which is due both to heater voltage variations and life.

Under these conditions, many a tube will be removed from its socket because the circuit is not operating reliably. The same tube may be perfectly good if it is placed in a circuit in which tube conditions are correct. Studies of tubes removed from thousands of sockets reveal that at least 30 percent test out as being within normal tolerances, and the facts cited by Erdle may explain the reason for some of this large loss of tube life.

The chief advantages attributed to starvation circuits are high gain, low current drain, great stability, and long life. On the contrary, tubes operated in this way generally tend to be unstable, with variations in supply voltage and life. Life in such circuits can be radically reduced, even though the current requirements happen to be mild. Use of starvation circuits can lead to selection and replacement problems.

Higher gain, in some cases, and lower current drain can be achieved with starvation circuits, but only at the expense of potential difficulty in the manufacture and maintenance of equipment.

Where low current drain or high gain are the objectives, proper selection of tube types, such as a low-current, high- $\mu$  triode, or an efficient pentode, should provide an adequate solution without resorting to starvation circuits and their inherent limitations.

## GROUNDING TECHNIQUES

What constitutes "ground" and the reasons for grounding parts of circuits are not always too clear to the younger engineer. Equipment is grounded and portions of circuits are connected to ground to protect the equipment, to reduce coupling between elements in which no coupling is desired, and to ensure the safety of operating personnel. The metal chassis of any equipment must be at the same actual potential as the earth on which the operator stands. Otherwise, danger is always present, because in handling the equipment, the operator will complete the electrical circuit from metal chassis to actual "earth," and his body will have to conduct the current that will flow.

Every circuit that is not to be coupled to another circuit must be complete in itself. No circuit should require any portion of the chassis for continuity. The temptation to use three wires, one of them common to two circuits, instead of four wires, should always be resisted. One, and only one, point of each of these circuits should be connected to the chassis, and the chassis itself should be connected to the earth via the frame of the building or vehicle, or some other good "ground." When two or more circuits must be connected at their ground side, no ground current should flow through the chassis. In other words, do not use the chassis as an electrical conductor. The common wire in the case where circuits must be connected on the ground side must be large enough to carry the combined currents without appreciable IR drop along the conductor to act as a resistive coupling means.

The actual definition of what constitutes "ground" may be rather hazy. Weiss /25/ cites the example of a large fire control system, in which all the following were called "ground":

1. The frame of the vehicle
2. The metal frame of the various boxes housing the equipments
3. The neutral of the 3-phase, 400-cps power supply
4. The negative of the 28-volt d-c supply
5. The common wire of a 2-phase, 400-cps precision power supply system
6. The B- side of the computer power supply
7. The B- of the radar power supply

8. The low side of more than a dozen signal and computing circuits, after passing through filters, transformers, synchros, resolvers, or tachometers.

Marginal Testing. In calculators and computers employing thousands of tubes and other components in a conservative manner, the principal cause of equipment failure is simple deterioration, old age. The technique of marginal checking developed by computer engineers has proved to be an important aid in reducing "down" time by speeding up the location of a failed tube or other component and by systematically using a definite maintenance period (which may be at frequent intervals) for such checking; that is, when the machine is otherwise idle.

In this system, various portions of the equipment are subjected to deliberate variations of voltage of such magnitude that trouble will automatically show up. The marginal check gives a nondestructive, quantitative measure of the operating tolerances under which the machine is working. A circuit in which the  $S_m$  of a tube must be above a certain value for proper functioning may be tested by lowering the voltage to this tube, so that the circuit fails when the  $S_m$  resulting from lowered voltage has decreased to the failure point. The tube can be replaced in anticipation of its failure at some later time, which might be in the middle of an important run.

The complexity of the additional equipment needed to make this kind of test depends upon the circuits to be tested and the desired reliability.

It is stated that a 400-tube system had its reliability improved by a factor of 50 to 1 by this method. The value of the technique is apparent from the following figures.

Tube and crystal failures - 2,750 hours of operation

	<u>Tubes</u>	<u>Crystals</u>
Total number of components in use	3,500	4,500
Total failures from all causes	128	176
Number located by marginal checking	78	146

Thus, 61 percent of all tube failures and 84 percent of crystal failures were found by marginal testing. The other failures were mainly due to mechanical breakage or gas.

For details of this rather new technique, the reader is referred to the literature on computers, which is voluminous. The system as used at the Digital Computer Laboratory, MIT (Whirlwind computer) is well described in reports from this laboratory, particularly Memorandum M-2184, "Marginal Checking System Model II, WW I," by J. H. Hughes, dated 20 July 1953. Other data will be found in the Proceedings of Eastern Joint Computer Conference, 1953, published by the Institute of Radio Engineers.

Positive Feedback Usage. Sulzer cites some interesting applications of positive feedback as a means for eliminating bulky cathode and screen bypass capacitors and video compensating inductors./26/

Voltage-Stabilizer Circuit Design Problems.

The literature on voltage-stabilizer circuitry is voluminous, and since it is constantly being added to, the last word apparently has not yet been said. In designing such circuits, the effect of ordinary manufacturing tolerances in the resistors or tubes employed, or the temperature coefficients of the resistors, is often overlooked. It is significant in that the substitution of a new tube for an old one produces unexpected and undesired results. Hoyle has made some interesting analyses of a typical circuit, and the following comments are taken from his paper./27/

Two typical circuits are shown in Figure 5-29, and of these, (a) is preferable, although (b) is most often seen in the literature.

The problem is to choose  $R_1$ ,  $R_2$ , and  $R_v$  (the maximum value of  $r_v$ ).

Variable Output Voltage. Variation in output is provided by the variable  $r_v$ .

$$E_{\min} = \frac{V(R_1 + R_2)}{R_1} \quad (1)$$

$$E_{\max} = \frac{V(R_1 + R_v + R_2)}{R_1} \quad (2)$$

or 
$$\frac{R_v}{R_1} = \frac{(E_{\max} - E_{\min})}{V} \quad (3)$$

or 
$$\frac{R_v}{R_2} = \frac{(E_{\max} - E_{\min})}{(E_{\min} - V)} \quad (4)$$

In these equations, there are three unknowns,  $R_1$ ,  $R_2$ , and  $R_v$ , and if any one is known, the others can be found.

In general, a high value of  $r_v$  is desired to keep the bleeder current as low as possible. This calls for small wire on  $r_v$ , and for military applications, the minimum wire size may be a limiting factor.

If a given bleeder current is desired, instead of a minimum value as indicated above, then, according to Figure 5-29(a), it turns out that the bleeder current is

$$i = \frac{V}{R_1} \quad (5)$$

The value of  $R_v$  secured from the previous equations usually will not be of a standard value. Selecting the nearest standard value above the calculated value restricts the rotation of the potentiometer to cover the range, which may make adjustments difficult. If the nearest higher standard value is shunted with a fixed resistor, the linear relation between rotation and output voltage is destroyed. These effects may not be important in particular applications, but they must be taken into account.

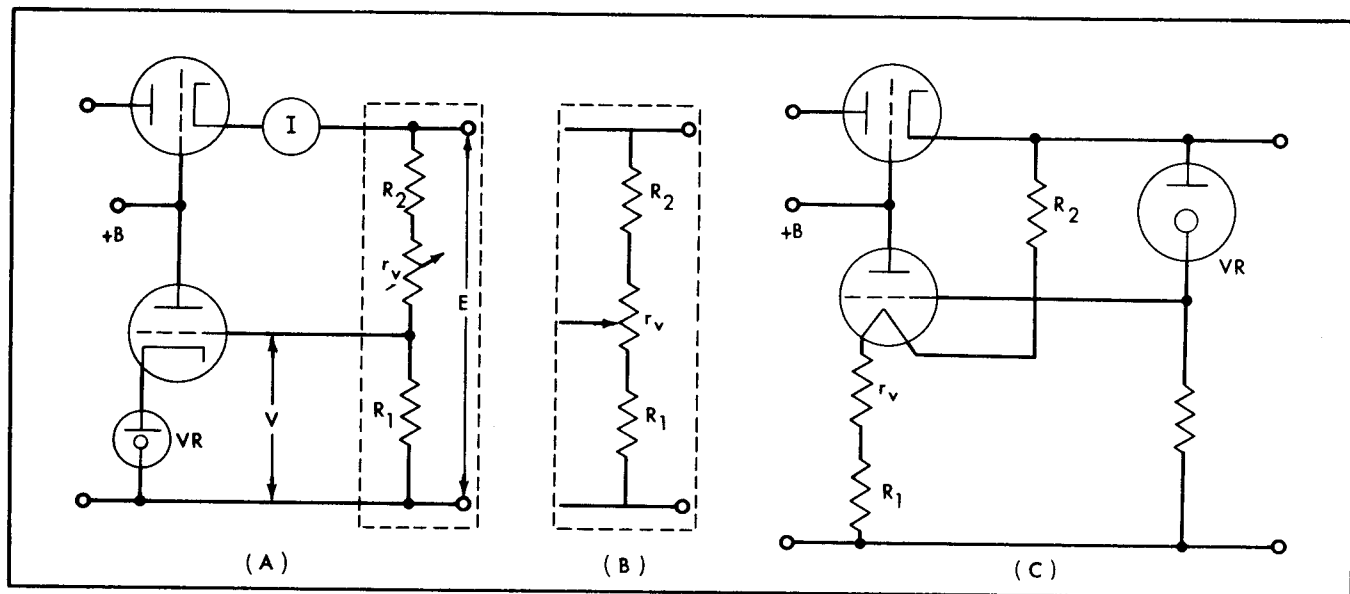

Figure 5-29. Voltage stabilizer circuits

Once  $R_v$  has been set, the other resistor values are obtainable from the equations above. If the bleeder current is given, then Equations (5) and (3) and the ratio of  $R_2/R_1$  will determine the proper values.

**Effect of Resistor Tolerances.** So far, no account has been taken of the fact that the resistors, unless carefully chosen, will have only nominal values, and that actual values will be these nominal values, plus or minus the manufacturing tolerance. Thus,  $R_1$  becomes  $R_1(1 \pm k)$ , and  $R_2$  has a similar value, where  $k$  is the tolerance per unit (not percent).

To calculate the resistance values, assume  $R_1$  and  $R_2$  have the same tolerances, that  $R_v$  is the lower of the manufacturers' limits,\* and the lower ( $V_{nr}$ ) and upper ( $V_{NR0}$ ) limits for  $VR$ , then

$$E_{\min} = V_N \left[ 1 + \frac{(1+k)R_2}{(1-k)R_1} \right] \quad (6)$$

$$E_{\max} = V_n \left[ 1 + \frac{(1-k)R_2}{(1+k)R_1} + \frac{R_v}{(1+k)R_1} \right] \quad (7)$$

$$\frac{R_2}{R_1} = \frac{(1-k)(E_{\min} - V_N)}{(1+k)V_N} \quad (8)$$

$$\frac{R_v}{R_1} = \left[ \frac{(1+k)(E_{\max} - V_n)}{V_n} \right] - \left[ \frac{(1-k)^2(E_{\min} - V_N)}{(1+k)V_N} \right] \quad (9)$$

$$\frac{R_v}{R_2} = \left[ \frac{(1+k)^2}{(1-k)} \right] \left[ \frac{(E_{\max} - V_n)}{(E_{\min} - V_N)} \right] \left[ \frac{V_N}{V_n} \right] - (1-k) \quad (10)$$

\* Thus, for a nominal 50-k unit, -10 percent  $R_v = 50k(1 - 0.1) = 45k$ .

In a particular case where the output limits were 180 and 300 volts, and 1 percent resistors were used for  $R_1$  and  $R_2$ , Hoyle found that  $R_1$  and  $R_2$  would be 36.3 and 38.8 kilohms without taking the tolerances into account and 25.6 and 24.0 kilohms if the tolerances are considered. Further calculations indicate that the useful range of  $r_v$  would be about 70 percent of its shaft rotation.

If this compression is unacceptable, a variable resistor in series with  $r_v$  (that is, in the string of  $R_1$ ,  $R_2$ , and  $r_v$ ) will enable the rotation spread to be increased to about 90 percent.

Other considerations are indicated in the Hoyle reference. He indicates why there is little, if anything, to be gained by placing the bleeder across the input to the stabilizer instead of across the output.

**Circuit Comparison.** The circuit of Figure 5-29(a) has greater stability; the output voltage is a linear function of the shaft rotation of  $r_v$ , whereas it is a hyperbolic function in the circuit of (b); the bleeder current is practically constant, whereas in the second circuit the bleeder current is proportional to output voltage and, therefore, less output current is available at higher output voltages. Furthermore, if the temperature coefficients of the fixed and the variable resistors are different, or if their thermal time constants are different, a variable bleeder current is a cause for an undesirable transient, of perhaps several minutes duration, which occurs when the output is varied. Figure 5-29(a) is preferable from this standpoint.

**Heater-Voltage Stabilization.** Much of the residual instability in most stabilizers arises from variations in cathode temperature. The circuit in

Figure 5-29(c) shows how the heater voltage may be stabilized even if the output voltage is varied over a wide range. It would be most useful with directly-heated cathodes./8/

Redundancy as a Reliability Asset. Considerable controversy exists over the possibilities of redundant systems for improving reliability. At the cost of additional weight and space, additional reliability may be obtained, provided that no device is necessary for making an intelligent decision as to which of the parallel channels is to be used. Even then, there is some additional reliability./28/ A mathematical analysis of this question is given in the reference, where it is shown that reliability increases as redundancy increases, in a parallel sense. This is true, providing that any one of the parallel devices suffices to perform the desired operation, and providing that the failure of no one element affects the operation of the others.

Thus, the use of parallel tubes, parallel resistors, and so on, will increase the chances of operation by one order of magnitude for each element added. If the individual reliability is 0.9, the reliability of two elements in parallel is 0.99, and of three, it will become 0.999.

If there are two paths, with a decision device that senses that one has failed and will switch to the other path, if the failure probability of the decision device is one order of magnitude better than the failure probability of the two paths, and if the chance that the device fails to switch when needed or switches when not needed is 0.01, the chance of total failure is 0.0118. If the switch never fails, then the reliability is simply that of two paths in parallel, or one order of magnitude better than a single path.

Other possible situations are analyzed in the reference.

Time as a Failure Parameter. Quite often, circuits depend upon a sequence of operations, rather than on a straight go-no-go basis. Thus, a relay contact may close, instituting a series of events occurring later in time. In addition to the chance that the relay may not close, there is also the chance that it may close prematurely, setting the sequence of operations into motion out of schedule. This could be very serious in some applications. Any study of such circuits to determine their reliability must include, therefore, a study of the probabilities of success, failure, and premature operation. In some cases, of course, premature functioning of the relay merely causes the circuit to nonfunction rather than to function too soon. If, for example, a switch in the cathode circuit of a thyratron trigger closes before plate voltage is applied, the circuit will not function until an entirely different type of signal is applied to the grid of the thyratron./29/

In designing reliable circuits from the standpoint of ensuring against nonfunctioning, the designer must consider whether he has, at the same time, increased the probability of premature operation. Very often, these contradictory aims go hand in hand, and

when they are so related, the total chance of success is the sum of the individual chances, one decreasing as the other increases.

Putting critical components in parallel (redundancy) will increase the reliability, but it may also increase the possibility of premature operation, and in sequence circuits this fact must be kept in mind. In such circuits, reliability is often increased by series-parallel circuit elements, the exact network being employed depending upon the desired balance between nonoperation and premature operation. Here, the exact nonfunction and premature operation probabilities need not be known; if their relative values are known, the network can be judged properly.

Other analyses and aspects of redundancy as a technique will be found in Carhart /30/ and Hamming. /31/ It is pointed out that a bridge designer employs redundancy of a sort when he puts more supports to his structure than are actually needed so that the load is shared and so that the failure of any one does not endanger the bridge. The telephone plant uses considerable redundancy, and in other communications systems, where service is of greater cost than the price of the extra equipment, redundancy is common practice.

Series and Parallel Redundancy. Redundancy is one way to buy greater reliability, but at the expense of increased number of parts, increased weight, and so on. The extra circuit elements can be added in parallel or in series with elements whose reliability is in doubt. Thus, if a capacitor is likely to open, then an additional capacitor in parallel will ensure that circuit functioning takes place, even if it is not exactly correct, whereas if the single capacitor opens, the circuit will not operate at all. Two rectifiers in parallel will aid where the rectifier is likely to fail by opening. If capacitors tend to short, then two in series will improve the chances of circuit functioning.

Thus, in shorting-type failures, add the extra component in series; in open-type failures, add the component in parallel.

In planning on redundancy, the most likely mode of failure of the components to be protected must be known, and the circuit must be able to function at a satisfactory level, even if not at topnotch, in case the expected component failure occurs.

The ideal situation is to employ redundancy where the affected component eliminates itself from the circuit upon failure. The remaining elements must have sufficient safety factors to carry on without failing in turn.

Frantik /29/ cites the possibility of two tubes operating so that one provides sufficient negative feedback to the other to keep the gain at the desired level, but when one tube fails, this feedback disappears and the gain of the stage increases to keep performance at a satisfactory level. He says, "resort to this type of circuit design may well be the only salvation of highly complex systems when components of only mediocre or poor reliability are available."



In employing parallel or series-parallel circuitry, one must guard against the creation of "sneak" circuits caused by a component failure. Usually, these situations show up as undesirable and unexpected return paths for power circuits. In dual-channel systems with common ground return, such troubles are very likely to occur.

The necessity for a decision device brings up the whole question of automatic failure detection circuits and devices. Failure in the output of a component can be detected in many ways: by comparison with the standard, if the output is constant, or by comparison with an independent determination of the output (for example, comparison of height from a radar heightfinder with the reading from a pressure altimeter). For any closed-loop feedback system, failures can be detected by modification and feedback of output to obtain a null-comparison with input (for example, dividing amplifier output voltage by the gain factor so that it corresponds to input voltage, with which it can then be compared). For single component functions, for discrete or digital functions, and for the detection of overt or complete failures, a cheap and reliable decision device can often be used. On the other hand, for complex component functions, for continuous or analog functions, and for detecting marginal failures or performance degradation, the decision device itself may become complex, expensive, and unreliable, and its use must be carefully considered in terms of the net gain to the system.

Much further study and experience is needed before a definitive case can be made out for redundancy as a design technique.

## ELECTRICAL HAZARDS

Electronic equipment, like all electrical apparatus, is dangerous to personnel and is subject to fire hazards. At the time of design, the practical aspects of these hazards must be considered.

Personnel Hazards. The principal contingency to guard against is shock. Even a small shock is dangerous. Burns or nervous-system injuries are not the only possible effects. Equipment damage and additional physical harm to personnel may result from the involuntary reactions that accompany electrical shock.

The amount of current that the body or parts of the body can tolerate is a function of the body paths involved. If the current passes from one hand to other, or from one hand to a foot, or from hands to feet, it is much more dangerous than if it merely passes through parts of an arm or leg.

A current of 100 ma through the body is very likely to be lethal; currents of 50 to 90 ma may kill; and if the current is in the range of 5 to 20 ma, the person involved "can't let go."/32/

How much current will flow? The current will follow Ohm's Law. Therefore, a knowledge of the resistance of the body or paths through the body is essential. Thus, the resistance between dry hands

may vary from 6,600 to 18,000 ohms, and if the voltage is 110, the current will be between 6 and 17 ma. The resistance between wet hands is of the order of 930 to 2,720 ohms, and if the voltage is 110, the current will be from 40 to 118 ma. This is dangerous. The resistance between dry hands and feet is from 1,500 to 13,500 ohms; the current, at 110 volts, is from 8 to 71 ma. Between wet hands and wet feet, the resistance varies from 610 to 1,260 ohms, and the current is from 87 to 180 ma at 110 volts. Between one wet hand and both feet, the resistance is of the order of 820 to 1,950 ohms, and the current may be between 56 and 134 ma.

Equipment Hazards. Fire is the chief contingency. High voltages can bridge small air clearances to start a conflagration, arcs are sources of fire, and overheated components are everpresent sources of incipient blazes.

Interlocks. A switch that automatically opens the power circuit when an access door, cover, or lid of a piece of equipment is opened is an extremely simple safeguard against all but the most careless workers. Where the equipment must be serviced with the power on, interlocks must be provided with some means for closing the circuit when the door is opened. In this case, they should be provided with visible means to show that danger exists. Men working constantly with high-voltage equipment are notoriously complacent and careless; their protection starts at the design and production stage.

Bleeder Resistors. Occasionally, one will find a circuit or a piece of equipment in which the power supply has no bleeder resistance permanently across the output. This is highly dangerous, since very lethal quantities of electrical energy can be stored for long times in modern leak-proof capacitors. The bleeder, of course, serves two purposes. One is to improve the regulation of the device. The other is to provide a discharge path for the filter capacitors when the charging source is removed or the line voltage is removed.

If no adequate bleeder exists, say for discharging the full load of the capacitors in one minute, then some means should be provided for discharging the capacitors before any maintenance work starts. A shorting or grounding rod with a well-insulated handle is often provided. It is probably better to discharge capacitors somewhat more slowly than is possible with a dead short to ground, and for this reason, a resistor of high power rating and of several thousand ohms is often provided.

General Precautions. Metal chassis should be at ground potential; ac-dc circuits are dangerous, unless very carefully engineered with respect to operator personnel protection. Meters or jacks in high-voltage leads must be viewed with suspicion — the meter should not have a metal zero-set; jacks should be in the ground side of high-voltage supply lines; set screws in knobs, dials, and so on, will be at the same potential as the shaft of the device to which they belong and, therefore, may be at high potential with respect to chassis.

Any equipment that has a cathode-ray tube in it is certain to operate on high voltages; r-f type high voltage power supplies not only have high d-c voltages, but r-f currents as well.

Series resistors to limit current flow in the event of shorts or equipment failure will protect many other components and may often prevent damage by fire.

Fail-Safe Circuits. A little care in design will prevent many complications when a component fails. The design should be such that only a limited damage results — the device "fails safe." Thus, a bleeder that opens up does not fail safe, because it removes the means for dissipating the energy stored in the capacitors. A shorting filter capacitor may cause a fire, because it forces the rectifier, transformer, or choke to carry a high short-circuit current,

thus producing more heat than normal. Power tubes relying on separate grid bias supplies are in imminent danger of being destroyed if the rectifier of the bias supply fails.

Fuses and overload switches are simple — and too often omitted — devices for protecting equipment and personnel.

The oldtimer's practice of keeping one hand in the pants pocket while the other hand explores hot circuits seems not to have been taught younger men — but it is still a good idea!

The literature on these subjects is sparse. Attention is drawn to "Safety Procedures in Electronic Equipment," published in the Aerovox Research Worker, March 1954, and digested in the NEL Reliability Design Handbook.

## REFERENCES

1. Noble, Daniel E., "Emphasize the Negative," 1954 Electronic Components Symposium, Washington, D. C., 4 May 1954.
2. Taylor, N. H., "Rudiments of Good Circuit Design," Report No. R-224, Digital Computer Laboratory, Massachusetts Institute of Technology, Cambridge, 19 May 1953.
3. Baran, Alex, "Radar Reliability," National Airborne Electronics Conference, Dayton, Ohio, 12 May 1954.
4. Muncy, J. H., "Feasibility Study of Electronic Circuit Standardization Equipment Analysis," National Bureau of Standards Report, 9 November 1953.
5. Luther, A. C., Jr., "Stability as a Factor in Circuit Design," Engineers Digest (RCA), March-April 1954.
6. Boyd, H. W., The Normalized Flip-Flop Chart, Report No. R-227, Lincoln Laboratory, Massachusetts Institute of Technology, Cambridge, 21 July 1953.
7. Thomas, Donald, paper delivered at February 1954 Meeting, Dayton Section, IRE.
8. Preferred Circuits Manual, National Bureau of Standards Report No. 3492, prepared for the Bureau of Aeronautics, Department of the Navy, Contract NAer 0135, 1 August 1954; and Notes to the Preferred Circuits Manual, NBS Report No. 3666, 1 September 1954.
9. Sandeman, E. K., Radio Engineering, John Wiley and Sons, Inc., 1948, p. 421. See also G. G. Gouriet, "High Stability Oscillator," Wireless Engineer, p.105, April 1950, and J.K. Clapp, "Frequency Stable LC Oscillators," p. 1295, Proceedings of the IRE, August 1954.
10. Sturley, K. R., Radio Receiver Design, Second Edition, 1953, John Wiley and Sons, Inc.
11. Optimum Thermal Compensation of Capacitance-Tuned LC Circuits, NRL Report 3688, and reported in NRL Letter Report, 15 August 1950.
12. Buttler, F., "Series-Resonant Crystal Oscillators," Wireless Engineer, Vol. 23, June 1946.
13. Heegner, K., Electrischen Nachrichten-Technik, Vol. 15, p. 346, 1938.
14. Buttler, F., "Cathode-Coupled Oscillators," Wireless Engineer, Vol. 21, November 1944; Schelesinger, Kurt, "Cathode-Follower Circuits," Proceedings of IRE, Vol. 33, December 1945.
15. Heising, R. A., Quartz Crystals for Electrical Circuits, Van Nostrand Co., Inc.
16. Meacham, L. A., "A Bridge Stabilized Oscillator," Proceedings of IRE, Vol. 26, October 1938.
17. Clapp, J. K., "A Bridge Controlled Oscillator," General Radio Experimenter, Vol. 18, No. 11, April 1944.

18. Mason, W. P., and I. E. Fair, "A New Direct Crystal-Controlled Oscillator for Ultra-Short Wave Frequencies," Proceedings of the IRE, Vol. 30, October 1942. See also Pullen, Keats A., "UHF Oscillator Design Notes," Tele-Tech, p. 80, February 1953.
19. Investigation of Oscillator Circuits for AN/ARC-22 and for Proposed Standards, Armour Research Foundation, June 22, 1953.
20. Clark, James M., "Automatic Frequency Control of Crystal Controlled Receiver Oscillators," Motorola Engineering Bulletin, August-September 1953.
21. Kelly, R. L., "Circuit Stability in Guided Missiles," Electronics, March 1954.
22. Smith, E. R., "Measurement of Tube Voltage Drop in Hot Cathodes," Electrical Engineering, p. 419, May 1950.
23. Edwards, D. V., and E. K. Smith, "Circuit Cushioning of Gas Filled Grid Controlled Rectifiers," Electrical Engineering, p. 640, October 1946.
24. Erdle, Paul J., "Starvation Circuits and Their Limitations," Sylvania Technologist, October 1953.
25. Weiss, Gerald, "Proper Wiring Design," Control Engineering, p. 49, September 1954.
26. Sulzer, Peter G., "Circuit Techniques for Miniaturization," Electronics, p. 98, August 1949.
27. Hoyle, W. G., "The Effect of Component Tolerances on Voltage Stabilizer Design," N.R.C. No. 2889, ERA-240, National Research Council of Canada, December 1952.
28. Gates, Clarence R., "The Reliability of Redundant Systems," Memorandum No. 20-76, Jet Propulsion Laboratory, California Institute of Technology, 27 August 1952.
29. Frantik, R. O., "The Determination, Application, and Limitations of Circuit Reliability Equations," Sandia Corporation Report SC-3288(TR), April 26, 1954.
30. Carhart, R. R., "Survey of the Current Status of the Electronic Reliability Problem," Report No. RM-1131, The Rand Corp., Santa Monica, Calif., August 14, 1953.
31. Hamming, R. W., "Error Detecting and Correcting Codes," Bell Laboratories Record, p. 103, May 1950.
32. Geigs, Karl S., "Can 110 Volts Kill?" Factory Management and Maintenance, p. 138, January 1954.

#### BIBLIOGRAPHY

- Bigbee, John H., "Regulated Power Supply Blocks," Electronics, July 1953.
- Brewer, E. E., "Testing Computer Elements," Electrical Manufacturing, June 1950.
- Hughes, J. H., "Marginal Checking System Model II, WW I," Memorandum No. M-2184, Massachusetts Institute of Technology, Cambridge, 20 July 1953.
- Langford-Smith, Radiotron Designers Handbook, Fourth Edition, Radio Corporation of America, Harrison, N. J.
- Mammola, J. P., "Electronically Regulated Transistor Power Supply," AFCRC Technical Report No. 53-12, April 1953.
- Michael, F. R., "Tube Failures in ENIAC," Electronics, October 1947.
- Moore, R. T., and R. S. Selleck, "Multioutput Common Reference Voltage Regulator System," Northrup American Report No. GM-769, 15 July 1953.
- NEL Reliability Design Handbook, U. S. Navy Electronics Laboratory, San Diego, Calif., 1954.
- Proceedings of the Eastern Joint Computer Conference, Joint IRE, AIEE, ACM Computer Committee, Washington, D. C., December 1953.
- Report on Electron Tube Survey of Instrument Manufacturers and Laboratories, AIEE Report, March 1948.

- Rich, E. S., "Computer Experience in Extending Tube Life," AIEE Northeastern District Meeting, Providence, R. I., April 1950.
- Richter, W., "Some Limitations of Electron Tubes," Electrical Manufacturing, March 1949.
- "Safety Procedures in Electronic Equipment," Aerovox Research Worker, March 1954.
- Searles, C. E., R. A. Sykes, and I. E. Fair, Information Bulletin on Quartz Crystals, Bell Telephone Laboratories, and available from the Armed Services Electro Standards Agency, Fort Monmouth, N. J.
- Steinberg, E. B., "How to Extend Electron Tube Life," Electrical Manufacturing, November 1950.
- Sumner, G. C., "Marginal Checking, Preventive Maintenance for Electronic Equipment," AIEE Northeastern District Meeting, Providence, R. I., April 1950.
- Wagner, J. L., and K. S. Kooh, "Functional Tests of Vacuum Tubes," Industrial Application of Vacuum Tubes, AIEE Report, September 1949.

# CONTENTS

## chapter six

### **mechanical and environmental factors**

**Design Objectives**

**Heat**

**Low Temperature**

**Miniaturization**

**Encapsulation**

**Hermetic Sealing**

**Moisture and Biological Growth**

**Salt Spray, Sand, and Dust**

**Shock and Vibration**

**Transportation and Storage**

**Installation**

# chapter 6

## MECHANICAL AND ENVIRONMENTAL FACTORS

Until recently, the design of electronic equipment was primarily the concern of electrical engineers. Many of these men, though well skilled in their own profession, were frequently unacquainted with or uninterested in the talents and skills that were being developed in allied engineering fields. The mechanical arts displayed in the making of such items as typewriters, adding machines, and timing mechanisms were undoubtedly excellent, but the electrical engineers had their own theoretical problems to solve, and these were of primary interest. Furthermore, the absence of these techniques was not too important in the early stages of electronics, when a radio set consisted of a few tubes mounted in a wooden box.

No such conditions can be tolerated today. As in other fields, the introduction of electronics into the military has had far-reaching effects. Its subsequent development and application has been so rapid and extensive that, today, military electronics may be considered a silent Service — responsible in its own sphere for the national defense.

The exceptional advancement in electronics has not been made without a corresponding increase in the responsibilities of the electronics designer. For a radio set to fail at home is an inconvenience; for a similar unit to fail in the military may be a disaster. It is, therefore, the duty and obligation of the designer to incorporate into his equipment both the latest knowledge of his particular field and the latest techniques developed in allied fields. In some instances, this may call for cooperation with other engineers and the necessity for compromise where a situation of conflicting interest arises. In other instances, it will call for the broadening of the field of interest of the designer. Whatever the need, it is incumbent upon the electronics designer to be as well-briefed as possible on mechanical and environmental factors.

This chapter presents the mechanical and environmental factors that must be known to the

engineer if his equipment is to withstand the critical conditions under which operation may be necessary. The specific items to be considered here are temperature, moisture, biological growth, salt spray, sand and dust, shock, and vibration. Since one item may assume greater importance than the others as the equipment or climatic conditions vary, the order in which these items are discussed should not be construed as an indication of their relative importance.

### DESIGN OBJECTIVES

The requirements for military equipment are usually more stringent than those for civilian use; therefore, it is only natural that military agencies be among the leaders in attempting to further integrate mechanical techniques with electronic designs. Equipment specifications written to meet these requirements usually call for increased reliability, smaller size, and less weight — all at a reasonable cost.

Reliability should be considered the most important design parameter in attempting to meet these demanding requirements. It matters little what claims are made for the power, sensitivity, or output of an equipment. If its reliability is questionable, it is of little military value. This means, among other things, that the cabinet and framework must properly support the equipment, that the equipment must not be injured by shock and vibration, that adequate provision be made for ventilation, and that such difficulties as moisture, dirt, and fungus growth be overcome. In other words, each part of a design not only must function properly in the overall picture, but must also be able to withstand all combinations of critical conditions that may occur in the field (Table 6-1).

### HEAT

The temperature of a region may be sufficiently high to have adverse effects on electronic equipments. In the tropics, shade temperatures may exceed 50 C

Table 6-1. Various extreme conditions of use that affect insulation materials /1/

Condition	Types of failure
High temperature ambient 60 C (up to 75 C in desert sun); in equipment up to 100 C, tending to increase in future	Melting of waxes; softening and flow of polymers; permanent set of rubbers, warping of laminates; embrittlement of cellulosic materials; rise in power factor and leakage loss; drop in breakdown strength; increased chemical or electrochemical deterioration.
Low temperature -40 C (to -70 C in exposed Arctic regions)	Cracking of waxes; embrittlement of cables (rubber and polythene); failure of rubber seals; embrittlement of plastics leading to failure if vibration is present.
Humidity 90-100% R.H., including condensation, at temperatures in the region 40-25 C	Surface and volume leakage; electrochemical decomposition or breakdown; particularly under d-c conditions; swelling and warping of many plastics; loss of tensile strength in paper.
Fungi, bacteria, and pests	Attack particularly cellulosic materials, with destruction of the material or formation of leakage paths. Mould will also grow on any sticky surface able to collect organic dust; also on fingerprints on smooth surfaces.
Dust	Surfaces of insulating materials not quite hard and dry will collect dust, which may form leakage paths under subsequent humid conditions, or lead to mould attack.

for short periods of time, while the temperatures of exposed places, subjected to the direct rays of the sun, would naturally surpass this./2/ A reading of 82 C has been recorded on the floor of Death Valley, California. Apparatus mounted in an exposed position may be expected to absorb heat and experience an internal temperature rise. This rise will be dependent upon such factors as the absorbing properties of the housing finish, the circulation of air over the exterior surface of the housing, the ventilation or circulation provided to the interior, and the ambient air temperature.

Effects of High Temperature. Many perplexing problems are presented to the designer by requiring his equipment to operate in the temperature ranges just mentioned. The internal temperature of the equipment may approach a value where low melting point materials become soft or even begin to flow. When it is realized that greases, protective compounds, and waxes are included in this category, the seriousness of the problem is apparent. Most thermoplastics have heat distortion temperatures below 95 C, while the deterioration of cellulose insulation begins around 100 C, with a resultant increase in power factor and decrease in dielectric strength as temperatures rise to higher values. The differential expansion of different materials can cause a distortion of assemblies, a rupture of seals, and the binding of moving parts. "Aging" processes are promoted by high temperatures, so that decomposition of organic materials increases and rubber materials harden and set.

As described by Steinberg and Oliver, /3/ a sudden change in operating temperature may not cause an immediate corresponding shift in the electrical characteristics of a tube, but continued high temperatures can bring about tube failure. The lead wire seal is destroyed by electrolysis, and a slow evolution of gases takes place from the glass and other parts of the tube. This results in a gradual deterioration of cathode activity and of the insulating surfaces. The chapter on Component Parts discusses the specific effects of high temperatures on tube performance and life.

On occasion, a high ambient temperature can be a blessing in disguise. Communication equipment operates better under conditions of high humidity if the temperature is also high. The most pressing problem facing the electronic designer today, however, still is how to get rid of heat. There are, at present, three trends in the electronics industry that require equipments to operate at higher temperature levels. These are miniaturization, casting or encapsulation, and hermetic sealing. Each of these are discussed in separate sections of this chapter.

Heat Transfer. Conduction, convection, and radiation are the three fundamental methods of heat transfer. Conduction is the transfer of heat from one part of a body to another part of the same body, or to a second body in physical contact with the first, without any progressive motion of the particles of the body. Convection is the transfer of heat from one place to another by the motion of the

heated substance. When the transfer is entirely due to the change of density of the substance, it is called free, or natural, convection. Forced convection makes use of mechanical means, such as pumps, to aid the heat transfer. Radiation may be described as a threefold process: (1) the conversion of the heat energy of the hot body into transverse wave motion, (2) the transfer of the wave motion through space, and (3) the reconversion of the wave motion into heat by the second body.

Factors Affecting Conduction. The amount of heat that will flow because of thermal conductivity is dependent upon the following relationships:

1. The quantity of heat passing through a conductor in a given time is directly proportional to the area of the conductor and inversely proportional to its length.
2. The quantity of heat that will flow is also directly proportional to the temperature difference between the two points under consideration. There is no thermal conduction of heat unless a temperature difference exists.
3. It must be remembered also that the thermal conductivity of a substance is dependent upon the temperature and the crystalline state of the substance. The thermal conductivity of metal decreases with an increase in temperature, while that of carbon increases with the temperature. When a substance like sulfur changes its crystalline state, an abrupt change takes place in its thermal conductivity.

Factors Affecting Radiation. The amount of heat radiated by a body is a function of its temperature and the character and area of its radiation surface. Generally speaking, polished surfaces make poor radiators, while rough surfaces make good ones. Lampblack has such an excellent radiating surface that it is used as a standard of comparison for other radiating surfaces. An increase in the radiating surface of a body will increase the amount of heat that the body will radiate.

There is a definite relationship between the rate at which a surface radiates heat and the rate at which the same surface, under the same set of conditions, absorbs heat. This relationship may be stated by saying that a good radiator of heat is also a good absorber of heat, or that surfaces that radiate slowly also absorb slowly.

The amount of radiant heat reflected from a surface is also dependent upon the character of the surface, that is, polished surfaces reflect the best, and black or roughened surfaces reflect the poorest. In other words, surfaces that are good for absorbing heat are poor reflectors.

Ultimate Sinks for the Dissipation of Heat. The mode by which the heat is transferred to the sink is optional, based upon the design configuration and environment. /4/ Directly or indirectly,

the earth or its atmosphere absorbs the heat and becomes the ultimate sink. It is necessary, therefore, in any heat removal system, that an ultimate sink "connection" of low thermal impedance be employed.

In simple cooling systems utilizing natural, or "brute force," methods, the heat is usually dissipated directly from the surface of the unit to the atmosphere. With such systems, heat removal and ejection to the surrounding environment is readily accomplished, so long as the equipments are of low power densities, and have adequate exposed surface area. With equipments of higher power densities, of the order of 0.25 watts per square inch or more, heat ejection becomes difficult. It is in this field that further investigation is taking place.

The choice of the ultimate sink depends upon the type of equipment that is being cooled, the type of environment in which it is operated, and the type of sinks of unlimited capacity that may be available. When forced-air cooling is utilized, the heated air is usually dissipated directly to the atmosphere, while a new supply of air is obtained from the atmosphere to cool the equipment. If the equipment is convenient to a liquid sink, an air-to-liquid heat exchanger may be utilized to remove the heat from the air, so that the air may be recirculated in the system. With liquid cooling systems, the heat may be ejected from the liquid to the atmosphere by means of a liquid-to-forced-air heat exchanger. If a liquid sink is available, a liquid-to-liquid heat exchanger can be used to eject the heat to the sink. It is also possible to employ the latent heat of vaporization of a liquid as an ultimate sink. In expendable vaporization cooling systems, the vapor is directly vented to the atmosphere. Vaporization cooling can be provided either to cool the electronic equipment directly or to act as the ultimate sink for a forced air-to-liquid cooling system.

Present State of the Art. Though it is fairly well recognized that thermal engineering is a significant factor in the reliability of electronic design, the heat transfer techniques presently applied are in an early stage of development, and the thermal findings of several organizations differ from those of others. Some confusion and disagreement naturally has followed. This is a healthy condition, in that recognition of the importance of adequate heat removal by the electronics industry will aid in the ultimate alleviation of the problem, but, nevertheless, it does present the designer with one more hurdle to overcome.

The current approach to the situation is to separate the problem into two tasks. The first has to do with internal heat-transfer design, and deals with those factors that must be considered in the transfer of heat from individual power-dissipating components to the external shell of the primary equipment. The second task is external heat-transfer design. This takes into consideration the transfer of generated heat from the equipment shell to an ultimate heat sink. In some applications, such as mobile equipment and aircraft, the latter phase may be further broken down into the transfer of heat from



the shell to a refrigerator or other exchange point and the subsequent transfer to the final point of heat ejection.

The problems associated with external heat transfer are primarily those of the systems engineer or the engineer charged with the responsibility of adapting electronic systems to mobile equipment and aircraft. The problems of internal heat transfer are usually the immediate concern of the electronics equipment designer.

Heat Removal Techniques. Heat removal techniques are probably the foremost problem facing the electronics designer today. This problem has been highlighted for two reasons: the relation between reliability and internal temperatures of assemblies, and the added problems in heat transfer imposed by miniaturization, encapsulating, and hermetic sealing.

One method of attacking the additional problems imposed by miniature construction is to rely upon the development of high-temperature components. Many such developments have been achieved, and the list is growing. The effort in itself, however, appears insufficient to meet today's requirements, since the achievement of a complete solution in this manner requires development of many new base materials and, consequently, will take a long time.

Many special cases exist where design groups have worked on and solved specific thermal problems, some of which will be described here. Conduction cooling has been used to good advantage by employing metal sleeves around tubes. These sleeves are firmly connected to the chassis, and offer a fairly low resistance path for heat transfer. Various solutions to the conduction of heat from resin-embedded assemblies have been used. One solution employs the technique of conduction from a sleeve to the chassis. In this example, the hot spot temperature in an embedded assembly containing an SN-955 tube was held to 15 C above ambient. The assemblies in another case rely on heavy bus wires and screens molded into the package to conduct heat from internal hot spots. The screens are wrapped around the tubes to serve as electrical shields, as well as aids to heat conduction. At the Navy Electronics Laboratory, "floating" metal shields have been used around subminiature tubes within resin castings. These are helpful, even when not connected to any chassis, since they distribute hot spots over a large area.

Heat Insulation. The converse of this approach has also been used. In some assemblies, asbestos shields have been used to keep heat away from critical points. In conjunction with printed circuits, metal sheets, covered on an exterior face with an insulating material, serve to distribute internally generated heat and to limit the effects of externally generated heat. Convection cooling is being used in England in an experimental airborne monitor. The equipment is housed in a hermetically-sealed cylinder of circular cross section. The components are arranged so that convection currents from hot spots flow along a considerable surface area

of the enclosing can. These currents are deflected to protect critical components in the bottom of the assemblies. Another technique is the use of vertical metal chassis, which form chimneys throughout racks of equipment. Components having high heat dissipation are mounted on one side of a chassis, and components to be protected are mounted on the other side.

Air Cooling. Hermetically-sealed assemblies have been cooled by a number of methods. Nitrogen filling has been used by the National Bureau of Standards. Several groups are considering the use of hydrogen in sealed packages. Conduction and forced convection to cool hermetically-sealed assemblies are employed in one piece of equipment. Two sealed units are fastened together, with a heat transfer unit between them. Fans within the sealed container circulate air to conduct heat to the container walls. This heat is then transferred by conduction to the heat-transfer unit, where it is carried away by forced air. In another instance, to remove heat from a sealed, cylindrical assembly, the container walls have been made up in the form of two coaxial cylinders. Ribs are welded between the cylinders, leaving a system of ducts through which cooling air is forced.

For detailed information on heat removal, the attention of the designer is directed to current textbooks and reports on Government-sponsored studies. Particular attention should be given to the work that has been done on this subject at Ohio State University Research Foundation and Cornell Aeronautical Laboratory. A partial list of the reports by these organizations is found in the bibliography at the end of this section.

#### MEANS OF INCREASING HEAT DISSIPATION

A survey of current heat removal problems seems to show that their solution may be found by the ingenious application of a few fundamentals. As such, the following are offered.

##### To Enhance Conduction.

1. Provide good thermal bonding, which means nonoxidized contact surfaces, welded or brazed joints instead of securing by fasteners, and the use of braids instead of strips to make contact.
2. High-conductivity materials, such as silver, gold, or copper, may be used. Silver, in particular, is an excellent heat-transfer means. Aluminum makes a satisfactory overall structural material because it conducts well. Keep in mind that thermal conductivity for metals is generally in direct proportion to electrical conductivity.
3. The use of oil or hydrogen.
4. The use of the technique of diversion by conducting the heat to a relatively large mass that is in proximity to the element.

### To Enhance Radiation.

1. **Materials with high emissivity and absorptivity should be used.** The emissivity of polished aluminum is very much less than that of oxidized steel. If the temperature of an object to be cooled is high, the area that the hot object "sees" should be a metal that will absorb the heat rather than reflect it back to the hot element. Materials with high emissivity and absorptivity are oxidized steel surfaces, painted surfaces, and artificially corroded surfaces. Materials with low emissivity and absorptivity are rolled aluminum, bright plated objects, and cold-formed metal surfaces in general.
2. Radiation can be increased by raising the temperature of the radiating body and/or lowering the temperature of the object that is to receive the radiation.
3. The geometry of the radiating and receiving body can be devised so that the receiving body will accept more heat and reflect back less than would be the case if straightforward construction were used. This is a complex subject, and reference to available textbooks should be made. It is always necessary to minimize the possibility of reflection back to the hot bodies, with consequent increase in their temperature.

### To Enhance Convection.

1. Convection can be increased by high air velocity over the surfaces to be cooled, so that there is no stagnation or hot pockets.
2. In cooling by high velocity, it is necessary to achieve good scrubbing. The path of the air should be directed, to ensure that the object to be cooled is completely wiped. In addition, there should be no areas of low thermal conductivity resulting from thick laminar layers.
3. Auxiliary systems can be used. Although this involves some sort of refrigeration, it may be necessary in some instances. The Hilsch tube, while not efficient, is extremely simple, and may have some application./4/
4. Compressed-air cooling has good possibilities, since it simplifies air-filtering problems, uses small openings, and allows the air to be directed accurately. There may also be some advantage to keeping the equipment under a small pressure. The Hilsch tube can be used in conjunction with compressed air.

Blowers for Air-Cooled Equipment. Design, modification, and experimental evaluation of electronic equipment that is air cooled by forced convection requires familiarity with the various types of applicable blowers, a thorough understanding of their operating characteristics, and the ability to determine their performance under specified operational conditions./5/

Blowers used as a source of air motion for the cooling of electronic equipment fall into two general categories. They are (1) internal devices in closed equipments, producing circulating air flow over the components, and (2) devices supplying external cooling air for the dissipation of heat by forced convection from the ultimate heat transfer surfaces of the equipments. Internal devices of the first category are employed to establish uniform thermal conditions within the equipment. They aid in the transfer of heat from components to the equipment case surfaces, or to other heat exchange surfaces utilized for external heat dissipation. Whether the external heat dissipation takes place by free convection, forced convection, radiation, or a combination of these modes, the selection of the internal blower is influenced only indirectly. The principal requirement the blower must fulfill is that the air distribution within the equipment be suitable for heat dissipation from individual components.

Devices of the second category are used with open or closed equipments. They may produce cooling air that flows directly over the surfaces of components, or they may supply cooling air to external heat-dissipating surfaces, such as the case surface proper, or to extended surfaces forming a case-envelope or separate heat exchanger.

In many instances, the internal and external phases of heat dissipation are divorced with regard to blower selection and application. In choosing a blower for internal air circulation in pressurized or closed vented equipment, the selection is principally affected by the pressure level within the equipment and by the air flow and distribution requirements derived from a knowledge of component hot spots, their severity, and their location. With pressurized equipments, the basic problem of proper cooling under variable operational conditions rests primarily upon the ability to provide adequate heat dissipation from the case surface. The requirements imposed on internal blowers of such equipments are constant for all operational conditions. Therefore, such internal blower-motor units may be selected to operate at constant speed, which would result in the same air circulation rate under all operational conditions, since the internal pressure level of such equipments would remain essentially fixed. With closed vented equipments, internal blower-motor units having no means of control may be used, provided that for all operational conditions, the external heat dissipation from the equipment case is sufficient to prevent overheating of components contained within the equipment.

Among blowers of the second category, used to supply air for direct dissipation of heat, either by flow over components or over the surface of the equipment, the demands placed on their operational

characteristics are considerably more severe. In many instances, unattainable variations in air flow requirements may result, if it is necessary to cool the components over a wide range of operational pressure levels. Careful evaluation of the equipment's heat-transfer and pressure-drop characteristics is required as the basis for blower evaluation or selection. Knowledge of the variation of system pressure-drop and air quantity, required to provide adequate cooling in the prescribed range of operational conditions, is essential to determine the adequacy of a blower that is to serve as an air source for ultimate, or external, heat dissipation. Once these characteristics are established, the cooling performance of a blower and drive unit of known characteristics may be predicted, if they are operated with the equipment under specified conditions of air temperature and pressure.

Finally, it must be remembered that the purpose of a blower that reduces temperatures of equipment and components is to improve the reliability of the equipment. Therefore, the blower itself must be more reliable than the equipment would be without a blower. If the blower tends to fail because of heated (or cold) bearings, vibration, or shock sooner than the equipment would fail without the blower, then no increase in reliability has been attained by its use.

**Geometrical Considerations.** It may be necessary to arrange the equipment geometry so that the heat is generated near the outside of the equipment. Short thermal paths to the case are thereby provided. It may even be necessary to locate the very hot components externally, or to have separate vents for them.

The very simple matter of separating an oscillator tube from the frequency-determining elements, so that the dimensions of the latter will not be affected by heat from the tube, is well known in the electronic art, and similar mechanical considerations apply to the general reliability problem.

## LOW TEMPERATURES

Present military needs, and future military planning, call for the operation of a wide variety of equipments at very low temperatures. During World War II, the lower temperature limit most often specified for equipment operation was  $-20^{\circ}\text{C}$ , and this was regarded by many as a rather severe and extreme condition./6/ Since the close of the war, however, this temperature limit has been set even lower, and now stands at  $-35^{\circ}\text{C}$ .

Information brought back by observers of low-temperature military operations in the Hudson Bay region and Alaska indicates that temperatures below  $-30^{\circ}\text{C}$  are not unusual, and that equipment operation and human functioning at these extremely low temperatures are not simple matters.

**Equipment Operation.** At temperatures of about  $-40^{\circ}\text{C}$  and below, many components cease to function, on account of the physical changes that occur within them./2/ At these temperatures, electrolytic capacitors become completely unsuitable,

quartz crystals frequently fail to oscillate, storage battery electrolytes solidify, and dry batteries are unstable. Furthermore, ordinary lubricants harden, and the rotating shafts, gears, and bearings of equipment may "freeze." Waxes and protective compounds stiffen and crack. Rubber and rubber compounds, in general, lose their flexibility, and become hard and brittle. With changes in temperature, the variations in the capacitance, inductance, and resistance of component parts may become so great as to require readjustment in critical circuits. While the difficulties that exist at these temperatures affect all equipment, the nature of the difficulties for a specific piece of equipment must, of necessity, be determined by the nature of the equipment. For example, equipments having moving parts that require lubrication pose problems quite different from those existing for the lead-acid storage battery, which provides electrochemical energy.

**Human Functioning.** A man can easily be handicapped, physically and psychologically, by Arctic conditions. When a man is cold, or is afraid of the cold, his efficiency and incentive are greatly impaired. He loses his usefulness for the type of work to which he has been assigned./7/ To understand the magnitude of this problem better, one must be familiar with the weather conditions encountered in this region. During the winter season, weather is recorded in terms of "windchill." In common parlance, windchill is a combination of degrees of temperature plus wind velocity as measured against a heated or heat-producing body (Figures 6-1, 6-2, and 6-3). The actual formula is available on the "Nomogram of dry-shade atmosphere cooling" shown in Figure 6-4. The windchill factor varies from cool, windchill factor 400, to as high as windchill factor 2600, which is the

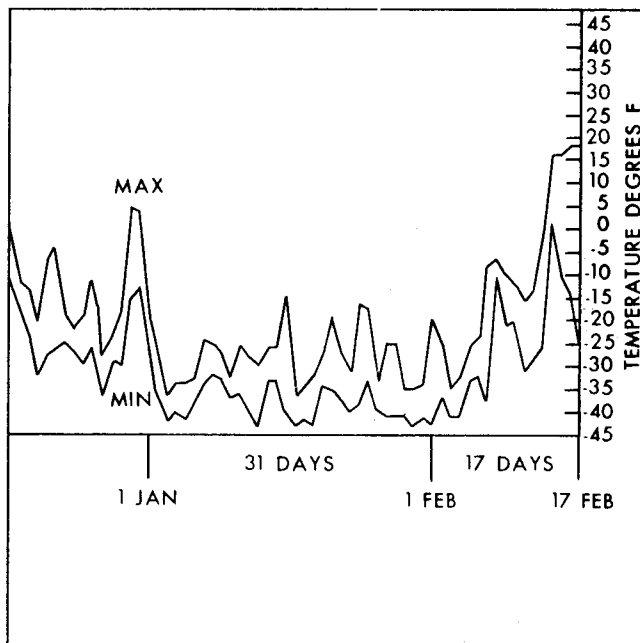

Figure 6-1. Record of temperature, Fort Churchill, Canada. (Courtesy of U. S. Army Signal Corps)

upper limit of human endurance. It is interesting to note that a windchill factor of 2280, which is often encountered in the Arctic, is produced by a temperature of -35 F, accompanied by a wind velocity of 25 mph, and is equivalent to an ambient still-air temperature of -109.3 F./8/

In a report by Dr. John Hunter and M. G. Whillans, /9/ it is stated, 'When the hands are exposed to severe cold, especially immersed in cold fluids, or when cold objects are being handled, the finger joints may become so stiff that the hands become almost useless. Lesser degrees of stiffness may significantly impair dexterity. The military significance of such impairment is obvious. It is not clear how much of this joint stiffness is the result of a local change in the physical state of the tissues or how much is due to muscle spasm accompanying pain or whether it is a combination of both factors.'

**Snow Load.** Effects of snow on military equipment are of different kinds, and the design criteria depend upon the nature of the equipment. Of the three effects listed below, /10/ only the first is of primary importance to the electronics designer. Nevertheless, recognition must be given to the other two, for though they are of secondary importance, they still play a part in the overall reliability of electronic equipment. The three effects are:

1. Impeding operation of equipment by sifting into cabinets, cases, and other exposed parts.
2. Imposing a structural load on buildings, structures (antennas and masts), and so on.

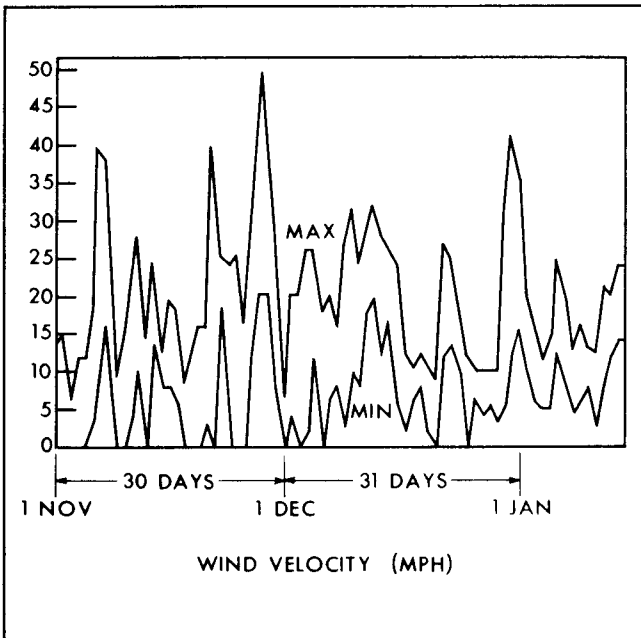

Figure 6-2. Record of wind velocity, Fort Churchill, Canada. (Courtesy of U. S. Army Signal Corps)

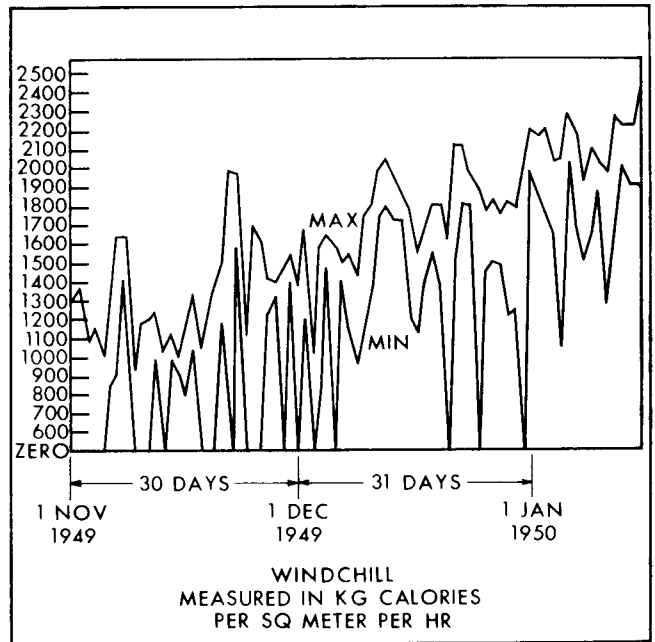

Figure 6-3. Record of windchill, Fort Churchill, Canada. (Courtesy of U. S. Army Signal Corps)

3. Impeding movement and transportation by accumulating on the ground.

The principal danger of blowing snow is that it may gain access to the interior of an item and clog it up, or else melt and refreeze inside as solid ice. Delicate mechanical parts may be damaged beyond repair; protective devices, such as shelters, may have pools of water formed within them, becoming hazards to personnel or creating morale problems. Blowing snow may be encountered in almost all places poleward of the tropics - in the air, at sea, and on land, and

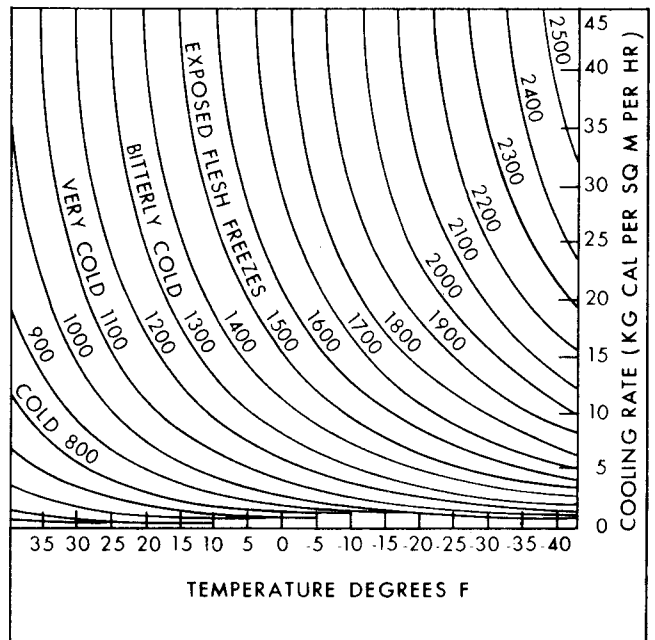

Figure 6-4. Nomogram of dry-shade atmosphere. (Courtesy of U. S. Army Signal Corps)

must be considered in the design of much military equipment.

The smaller the snow crystal, and the faster it is blowing, the more easily it can gain access to the interior of equipment. Snow crystals may vary in size, from a small fraction of a mm to 1 1/2 mm. Flakes as large as 15 by 8 in. have been observed at Fort Keogh, Montana./11/ Winds that blow snow may vary from the very light wind, which will just pick up fresh, cold snow, to the extreme winds of over 100 mph during snow squalls in the Aleutians, when temperatures hover about freezing.

It must also be remembered that in the open, winds will blow snow into equipment, if it is open for maintenance. When the set is subsequently operated, the snow melts, and later freezes inside the case, binding moving parts and insulating exposed contacts, such as those found on relays and switches. In this connection, difficulties will also be experienced with equipment taken from moist, warm rooms to the cold outside because of condensation of moisture inside the equipment.

Collapse of a structure through inability to withstand the load imposed by accumulated snow will probably result in an interruption of operation or damage to equipment and injury to personnel. With regard to shelters, the choice of design criteria is very difficult, and a compromise must usually be arrived at, since any increase in the bearing strength of a shelter also increases its weight and cost and decreases its portability and utility.

With regard to transportation, the rugged terrain and the probable predominance of track- and sled-type vehicles imposes a requirement for equipments with a high degree of resistance to shock and vibration. Thawing of the permafrost during the Arctic summer presents an additional problem, in that the muskeg becomes soft to varying depths, resulting in impassable bogs.

Maintenance. Maintenance in the Arctic is unique in that, for the most part, those measures that are normally within the capabilities of the trained operator of equipment in temperate zones, with the exception of visual inspection and cleaning of the outer surface, would necessarily revert to the second-echelon maintenance man./8/ A considerable number of the tasks that a second echelon maintenance man should normally perform would revert to third echelon or higher, unless adequate shelter could be provided. As previously explained, fine, powdered snow, which is blown by the ever-present wind, will penetrate the slightest crack or opening in equipment, and will melt when the unit generates heat resulting from operation. The melted snow may cause short circuits, particularly in the subminiature radio sets, small dynamotors, and so on. In other equipment, if precautions are not taken, the above condition will cause rust, and possible deterioration of fabric and insulation. It is essential to lay some equipments completely open even to perform such minor duties as changing tubes or changing operating frequencies.

Preventive and organizational maintenance is a "must" and, regardless of temperature or climatic conditions, it has to be performed. It can be assumed that combat conditions would tend to decrease the efficiency of the maintenance repairman considerably more than would climatic conditions alone. Efforts should be concentrated, therefore, on providing the maximum information to assist the repairman in Arctic maintenance in the technical literature accompanying the equipment. (Refer to the chapter on Equipment Publications.)

In regard to the lubrication of rotating or moving parts, a claim has been made that only those components that are normally lubricated require low-temperature lubrication under Arctic conditions./7/ Items such as rotary switches, tuning devices, and variable resistors and capacitors, as used on sealed equipments, do not need lubrication for satisfactory operation. When an equipment is brought into a warm atmosphere after exposure to cold temperature, moisture tends to form on the outside of the equipment, but quickly evaporates if the equipment is sealed so that no moisture collects on the inside. Freezing will not occur when the equipment is taken outdoors under Arctic conditions because the air can retain very little absolute moisture, although the relative humidity may be of the order of 98 percent. Effectively, the atmosphere is very dry.

For batteries, it has been determined that in low-temperature operation, the freezing point of the electrolyte varies with its specific gravity, which, in turn, is a measure of the state of charge of the battery./6/ Variation of the freezing point with the specific gravity of the electrolyte used in the battery is given below.

Specific Gravity of electrolyte (corrected to 80 F)	Percent of charge	Freezing point (F)
1.280	100	-91
1.250	75	-62
1.220	50	-26
1.190	25	- 8
1.160	Discharged	+ 3

To lessen the danger of freezing of the electrolyte, it would seem desirable, if not imperative, for operation at temperatures below freezing, first to maintain the battery at nearly full charge at all times, and second, when possible, to raise the specific gravity of the electrolyte for a fully charged battery from 1.280 to 1.350.

## MINIATURIZATION

Miniaturization has been held out by some as the cure-all for the constant need for reduction in size and weight of electronic equipment. The art has developed with notable success, so far as components are concerned, with the reduction in electron tubes being particularly successful (see Figures 6-5 through 6-7). The T3 bulb of subminiature tubes provides about a 75 percent reduction over the T5-1/2 envelope

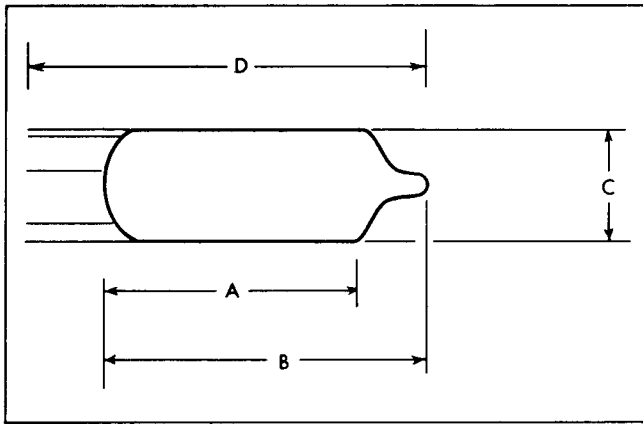

Figure 6-5. Standard RTMA sizes of miniature electron tubes.

1/3 of the so-called miniature tube, and over 80 percent reduction as compared with the T9 bulb. This advance, however, has not been made without the introduction of additional problems for the designer.

**Basic Requirements.** As pointed out by Jacobs, [12] the first basic requirement for miniaturization is that the reduction in size and weight must not be obtained at a sacrifice in performance or in the service conditions under which the equipment must function. The second requirement is the practical one that the art must be applied to the largest and most complex entity to be dealt with. This would eliminate the possibility that a group of miniaturized units might require so much cooling and pressurizing equipment as to leave the system the same size, or even larger, than before. Also, if the form factors of the miniaturized units were not compatible, precious space would be lost in assembly, which might nullify any savings gained by miniaturization.

**Problems.** Circuitwise, there are many conflicts with miniaturization. Stray capacitances and coupling have to be considered. If double-ended tubes

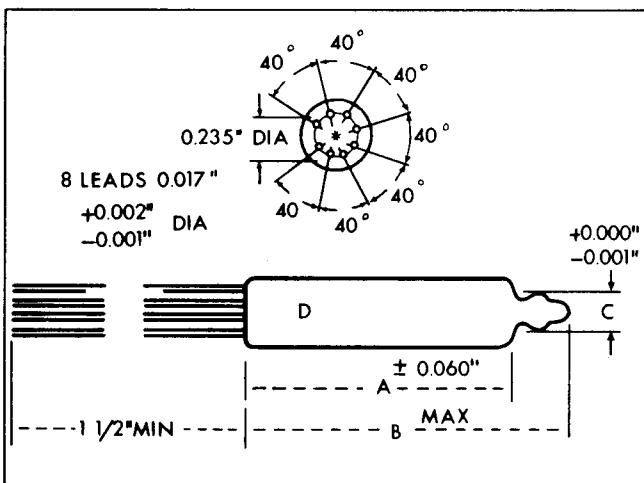

Figure 6-6. Standard RTMA sizes of subminiature electron tubes.

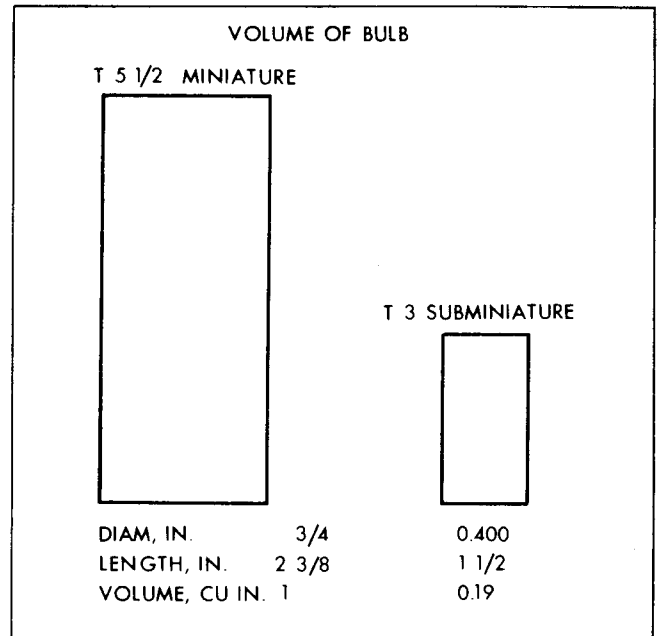

Figure 6-7. Relative volumes of miniature and sub-miniature tube bulbs, without pins or leads.

are used, adequate spacing must be allowed between the hot ends and any shielding. Voltage considerations require space separation to prevent arc-overs. The curves in Figure 6-8 reflect the results of tests performed at an ambient temperature of 25 C, 48 percent average relative humidity, and "Hi-pot" output frequency of 2 Mc. The electrode tip shapes and airgaps were selected because they closely resemble the condition encountered in miniature high-voltage design.

Heat dissipation is a problem that cuts across practically all types of equipments. As components of a given rating are made smaller and smaller and, at the same time, packaged closer together, it is obvious that the heating effect becomes aggravated and the need for cooling becomes more insistent. The haphazard use of blowers or other cooling devices can quickly nullify any miniaturization otherwise obtained.

The past few paragraphs have presented some of the problems that confront the designer who faces the increased demand for miniaturization. Though the approach to each new project will vary with the requirements peculiar to that job, the following material is offered as a solution to some of the questions that may be raised.

**Circuitry.** To eliminate the need for bulky components in circuit designs, the engineer should always question the need for each part and material. Designing a system in which as many of the functions as possible are performed at a fixed ground installation may decrease the demanding need for reduction of size and space. Installations can be better integrated to provide for common use of items such as power supplies, i-f and a-f amplifiers, and cooling systems. Advantage can be taken of some of the latest developments in 28-volt and 100-volt tubes to eliminate part or all of the power supply. Permeability

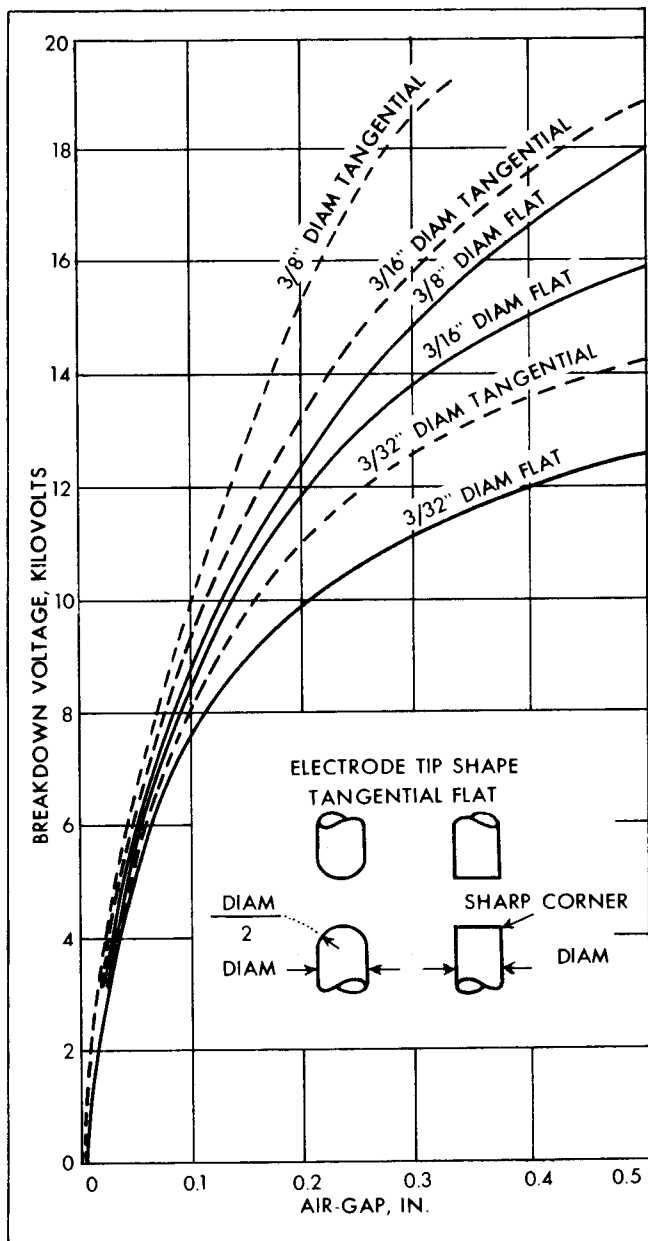

Figure 6-8. Space separations to prevent voltage arc-overs at 25 C, 48% average relative humidity, at 2 Mc.

tuning has been used to replace the bulkier gang capacitors. A circuit has been developed that, by the use of controlled positive feedback, can eliminate cathode and screen bypass capacitors in audio amplifiers or replace the larger compensating inductors of a video amplifier by small feedback capacitors./14/ In recent work on the miniaturization of i-f strips, the plate resistors and coupling capacitors, with the associated heat-dissipation problem, were replaced by a unity coupled bifilar-wound coil of substantially smaller size and weight./15/ In this same development, an input impedance-matching transformer was miniaturized by replacing it with a pi impedance-transforming network in which the input impedance of the first i-f tube served as the output leg of the pi.

**Components.** Of even greater importance to miniaturization is the development of new, improved, and smaller components. Here, the full impact of new material is apparent. The design engineer should keep himself well-informed in order to utilize these new components to their full advantage, to redesign, if necessary, for improved shape factor, and to help fill in the requirements where gaps exist in miniature components.

Subminiature tubes serve as a keystone for miniature design and construction. Most of them are for operation at as high as 400 Mc, with a plate dissipation of from 3 to 4 watts./13/ The minute dimensions of these tubes are such that the spacing between the grid and cathode may be of the order of a few mils. As such, a misalignment during assembly, or bending during the tube life, will cause failure. The minute dimensions, however, give the tube excellent mechanical ruggedness, because an element of smaller dimensions and lighter mass inherently possesses better resistance to mechanical shock than a larger and heavier element.

In World War II, the ability of the proximity fuse tube to withstand excessive shock was achieved by combining better tube mounting with improved tube construction. A cathode of oxide-coated tungsten proved to be less sensitive to shock than the previously used oxide-coated nickel. And, since tungsten could be pulled tighter, a more rigid element was obtained — thereby reducing the possibility of microphonics. The substitution of a coil spring in place of a cantilever helped provide more uniform tension of the filament between hot and cold conditions.

Two tests used to help eliminate heater failures are the aging of tubes for 50 hours before shipment, and an accelerated cycling test at 7.5 volts (for nominal 6.3 volt heaters). Normally, a tungsten heater is welded to a nickel connecting lead. Since there is a considerable difference in the melting points of these two metals, a poor weld is frequently formed between the tungsten and nickel. With the subsequent expansion and contraction of the heater caused by on-and-off operation, the weld may open after a relatively short period of time.

The adoption of tests similar to those above, plus better tube construction, has played a large part in providing subminiature tubes with a life expectancy of 5,000 hours at 30 C ambient and 1,000 hours life expectancy at 175 C./3/ These qualifications do not apply to all conditions under which service operation may be required but, instead, are based on the requirements set forth in applicable paragraphs of Specification JAN-1A for electron tubes.

Subminiature tubes are now available in enough types to cover substantially all of the receiving tube field, with the exception of power amplifiers over 1-watt output. Several socket designs are available, and individual contacts have also been used. For miniaturization purposes, however, the fullest benefit will be obtained if the subminiature tubes are soldered directly into the circuit.

Transistors and crystal diodes offer further miniaturization possibilities. It was the advent of the transistor in 1948 /16/ that led some people to predict that the elimination of burnt-out tubes and bulky electronic equipment was at last possible. The new components occupy about one thousandth of the volume, represent one hundredth of the weight, and require about one tenth the power of the average type radio tube, yet they perform many of the same functions. Transistors have the additional advantages of a rugged construction and a normal life expectancy approximately three times that of a vacuum tube.

On this basis, through the employment of transistors, it should be possible to fit a computer suitable for solving complex fire control problems into the space normally occupied by a shoebox. Yet, while these properties exist in theory, actual practice finds them more elusive. The production problems of transistors are legion. Unless properly sealed, transistors are greatly affected by humidity and heat. In applying the heat to obtain a good seal, the characteristics of the germanium surface change, and the result may or may not be a good transistor./17/ Another problem has been the lack of a suitable power source.

The introduction of the transistor naturally has raised the question of what components should be used in its circuitry. The same components that are used in electron tube circuits can be used for transistor circuits, but obviously it is desirable to select those that are comparable to the transistor in volume and weight. Heat considerations is another factor affecting this selection. At the present time, with only the germanium transistors readily available, the 85 C components will be adequate./18/ However, with the future availability of silicon transistors, which will be suitable for operation at much higher temperatures, the need will arise for components capable of operating in ambient temperatures up to 200 C.

In spite of present obstacles, transistors are capable of being used in circuits to provide amplification, oscillation, pulse generation, pulse counting, pulse storage, gating, pulse delay, coincidence gates, and so on./16/ Additional research and development will no doubt provide the possibility of using them to build systems that would not be feasible with vacuum tubes. The above facts, together with transistor technology, which is improving every day, will enable the designer of future electronic equipment to capitalize more fully on the inherent advantages possessed by these new components.

Military designers have been understandably hesitant to introduce transistors to military equipment. Enough trouble already exists from the reliability standpoint for designers not to wish to add new complications, that is, until they are certain that transistors will have no worse reliability record than the tubes they may replace.

Transformers are items that add much to weight and volume. If they are to be miniaturized, then for the same outputs, both the iron and the

copper must be operated at greater electrical, magnetic, and thermal densities. In the design of transformers, as well as relays, chokes, and other inductors, the space factor of magnetic wire becomes an important criterion.

New Materials. New materials play an important part in the development of miniaturized capacitors. The use of plastic dielectrics offers considerable savings in space and weight. Electrolytic capacitors, formerly used for low-frequency, low-impedance, bypass, and storage functions, are now employed in applications requiring high pulse energy storage. To reduce the power factor and current leakage of such capacitors, development is being directed toward reducing impurities in the aluminum used for roughened electrodes.

Heat Considerations. Though the general problems and design considerations associated with the removal of heat from electronic equipment are discussed elsewhere, it is felt that certain aspects of the problem related to miniaturization should be discussed here.

The problem lends itself to two avenues of approach. The first approach is the development of components that will operate satisfactorily at higher temperatures. Such components would be capable of still greater power in operation, further miniaturization, and closer proximity in the equipment design. Since all cooling techniques in use at the present time utilize the atmosphere as the ultimate heat sink, the quantity of heat that can be absorbed is proportional to the mass of air available and to the temperature differential involved. A cooling system, when needed for such a design, would be more efficient because of the existence of this greater temperature differential, and mediums not otherwise usable may now become good heat sinks.

The second approach to the problem is the development of techniques compatible with the trend toward miniaturization. With regard to this matter, it should be noted that where natural convection is the primary cooling means, components should be so arranged that vertical passages exist between them. Horizontal chassis or shields should be perforated, so that there is minimum obstruction to the action of this chimney effect. Where forced convection is used, a true circulatory pattern must be established, and baffling should be installed, so that as much of the temperature differential as possible is utilized.

A summation of the advantages and disadvantages of subminiature tubes may very well serve as a review of the current status of miniaturization. The outstanding advantage is, of course, their light weight, small size, and unusual ability to withstand shock. Subminiature tubes lend themselves very well to assembly with printed circuits and, with certain precautions, can be embedded in cast assemblies.

On the negative side, such tubes present a serious problem in heat dissipation. Their removal or insertion is usually more timeconsuming, since it may require the soldering of leads. The leads are



fragile, and may easily be bent, even if a tube socket is used. Test readings are usually difficult to take for want of space, plus the fact that the leads are frequently covered with sleeving.

Subminiature tubes cost more to produce than their equivalent miniature or octal-based type. In fact, miniaturized equipment design is inherently more expensive than what is now the conventional approach. More engineering time is required and new materials and components may be necessary. Without a market demanding this type of product, economic considerations may well dictate a cautious approach.

Making the electronics engineer miniaturization-conscious and establishing an economic motive do not by any means solve the technical problems, but they may well provide the needed environment for their solution.

## ENCAPSULATION

Basically, this process is not a new idea, since the "potting" of transformers, capacitors, filters, and so on has been practiced for quite some time. Asphaltic materials like tars and pitch usually require high temperatures for pouring and, generally, are not suitable to high-frequency and high-impedance operations because of their poor electrical properties. High-polymer resins are now being used to overcome most of these objections. In addition, the latter present a wide range of desirable and needed properties. At this point, it might be well to differentiate between the two processes. Potting usually involves the use of a pitch or wax. Only the physical process of melting the potting compound and pouring it in place is involved. The mold or case is left in place, and the resulting potting is comparatively soft in character. Casting or encapsulation involves the use of resin formulations, which, while they are also poured in place, require the chemical process of polymerization in order to set. The resulting casting is hard, and the mold can readily be stripped from it. These molds may be made of a variety of materials, such as metals, or Teflon and other rigid plastics. Mold release agents, such as kerosene, carnauba wax, and formulations like Simonize and silicone grease, are frequently used to prevent the adhesion of the resin to the mold surface.

Definitions. Casting resins are viscous liquids containing partial polymers, which will solidify on the application of heat. A casting resin is usually converted into a rigid plastic by the addition of a curing agent or a catalyst and accelerator, and it achieves this solid condition without the application of the considerable pressure and temperature normally associated with polymerization of thermal-setting resins. Catalysts are added to accelerate the chemical reactions that cause the resins to change from a partial polymer to a polymerized solid. Promoters or accelerators increase the activity of the catalysts to a degree disproportionate to the amount added. They are sometimes used together with a catalyst, and serve to make the latter more efficient in increasing the reaction rate. In the field of epoxide resin technology, curing agents are used instead of a catalyst and accelerator.

Embedding an Electronic Component. Although the actual encapsulating technique will vary from application to application, a typical method may be as follows:

1. The component is tested to ensure proper performance.
2. A suitable mold is designed to give the proper dimensions. Here, good design judgment must be used to ensure correct tapering, breaking off of sharp corners, and so on.
3. The inside of the mold is coated with a mold-release preparation, selection of which depends upon the type of resin used.
4. The component is placed in a mold and suitably positioned.
5. The mold and component may be preheated in an oven to drive off any absorbed moisture.
6. Immediately after removal from the oven, the prepared resin is poured into the mold, either under atmospheric conditions or under vacuum, depending on the degree of penetration desired. With coil, transformer, and capacitor impregnations, this must be done under vacuum.
7. The filled mold is then cured. In some instances, this must be done in a heated oven. However, many embedments are made at room temperature.

Embedment Possibilities. Two different avenues of approach are possible in the embedment of electronic assemblies. In one, the entire assembly is embedded in a large casting. Except when applied to short-lived expendable equipment, such as sonobuoys, proximity fuses, and control torpedoes, this technique has not proved too successful. The principal difficulty, of course, is component reliability, with tubes being the most serious offender. So long as the ratio of tube failures to other electronic components remains high, it will be impractical to pot or embed tubes in a large overall casting because, in most cases, the repair of embedded circuits is impractical. Solvents may be used to dissolve the resin, but this is time-consuming and often injurious to the elements of the circuit. Drilling and other machining processes may be employed, but these are also expensive and time-consuming, and are generally utilized only where clear resins have been used.

The second avenue of approach is unit casting or the embedding of components as a unit that will be discarded if trouble appears. This technique eliminates the problems associated with the first approach, and also possesses certain inherent advantages.

Advantages of Encapsulation. An analysis of current electronic equipments will bring out the fact that such items as cases, covers, chassis, brackets,

terminal boards, bolts, nuts, washers, and other miscellaneous hardware account for from 3 to 6 percent by volume, and from 20 to 30 percent by weight, of the total volume and weight. Unitized construction, since it involves the same fundamentals of fabrication, will still require roughly the same percentages for covers, brackets, and so on. A cast unit, on the other hand, will permit a saving of practically all this volume since, if the components can be held in place during the controlled period of casting, the resin itself will thereafter serve all the functions of the hardware. Although the resin occupies all free space in the unit, the specific gravity of the resins is generally less than half that of aluminum, while at the same time it becomes possible to utilize less heavily protected components in the assembly. Moreover, if the layout design is good, there will not be much free space in the unit (Figure 6-9).

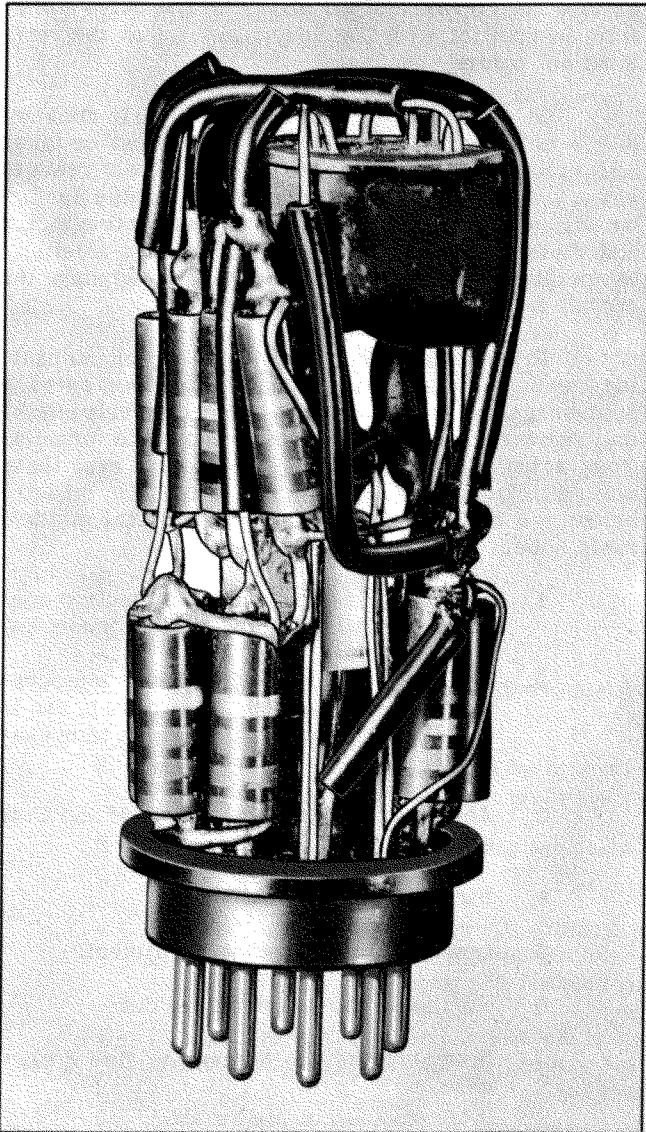

Figure 6-9. Transistor multivibrator ready for encapsulation. Note dense packing, point-to-point wiring, and lack of hardware. (Emerson & Cuming)

The complete embedment of the components of a circuit in these resins provides protection against deterioration by moisture, fungus, dirt, and so on. Usually, it increases the resistance of a unit to shock and vibration and, with proper tooling, it is a process that can be handled automatically. Shielding, when it is a problem, can easily be obtained by an overall spray of metallic paint.

**Design Considerations.** In designing an assembly for embedment, it must be borne in mind that the resin will have an effect on the circuit constants. Typical dielectric constants run from 2.5 to 4.0. The usual practice is to make preliminary tests to determine what these variations will be, and then incorporate these changes in the final design. In some castings, a small void is provided to allow for screw-driver adjustment. The void is filled in after the final adjustments have been made.

Care must be exercised in the embedment of precision components, since the resin may react with the materials of the component. The reaction may be due to the solvent action of the resin, the pressure due to its contraction on cooling, or the dimensional change of the components due to thermal cycling. These effects are not always reproducible in preliminary tests.

To embed subminiature tubes in thermosetting polyesters requires some precautions, since most of the resins contract during polymerization. The pressure that is then set up may be sufficient to break the bulb. To reduce this tendency, Steinberg and Oliver /3/ recommend that a suitable polyester be blended with the resin to produce a slightly nonrigid plastic composition, or that the mold be arranged in such a manner that only a thin film covers the tube. Alternate methods that have had good results are placing a nylon or silicone rubber jacket on the tube, or applying a resilient, spongy tube-coating compound to the tube surface prior to embedment.

All plastic materials are susceptible to the absorption and transmission of moisture. As pointed out in another section of this chapter, the absorption of moisture by an insulating material impairs its electrical characteristics, because its insulation resistance is decreased and its dielectric constant and dissipation factors increased. Should the moisture be transmitted to any element of the circuit, it would naturally have a direct effect on the circuit. In this matter, difficulties usually can be eliminated by a slight increase in the thickness of the resin.

Cuming /19/ has found that for unfilled polyester-type resins, 1/8 in. was adequate as a moisture seal on most sensitive components. One test that verified this result consisted of embedding a precision mica capacitor that was very sensitive to humidity in plastic with a coating of approximately 1/8 in. A rigid-type polyester resin, with a moisture transmission coefficient of 150 g per 100 sq m per hour (for 1 mil film), and a moisture absorption of 0.2 percent in 24 hours at 25 C, was used. The capacitor did not increase in capacitance or dissipation factor after 1,000 hours in 100 percent relative humidity. Cuming

since has stated that for general purposes, a 1/16-in. coating is adequate, but that such embedments should be made under a vacuum.

The most serious moisture problem that must be considered in the embedment of circuits or components is the seepage of water into the embedment at the interface between the plastic and the metal lead. Here, good practice dictates the use of solid, bare, single-conductor leads, and the location of the leads so that the plastic, on setting, will shrink onto the surface at which a seal is desired. In those cases requiring stranded wire, the leads should be bird-caged (spreading out of individual strands within the embedment for a short distance). This permits the plastic to seal itself around the individual strands and thereby provide greater resistance to moisture penetration. In general, to offset the moisture problem, it is recommended that casting resins with good adhesion qualities be used. It is also essential that the coefficient of expansion of the resin be equal to that of the particular metal.

At present, heat dissipation is probably the most serious problem. Resins suitable for casting electronic circuits must have low electrical conductivity. Unfortunately, materials with low electrical conductivity always seem to have low thermal conductivity also. (See Table 6-2.)

While the coefficient of thermal conductivity for the polyester resins is about ten times that of air, it is also about 1/1000 that of aluminum. Moreover, heated bodies exposed to air actually are cooled very little by conduction, and mainly by convection. In numerous embedments, it becomes necessary to use only components with fairly low heat dissipation. Otherwise, the thermal gradient through the casting would produce spot temperatures, which can destroy either the component or the casting. It is possible, in a few cases, to run dissipative components at lower surface temperatures in an embedment than in still air. This is due to the fact that the embedment excludes the presence of oxygen, which otherwise could attack the components.

The most effective attack on this problem so far has been to design the unit with sufficient metallic mass between the heat source and the surface to provide adequate conductive heat transfer. Though this is a compromise solution, calculations show that a small metallic conductor removes as much heat as a large "convection" surface.

The performance of many resins is satisfactory down to temperatures in the vicinity of -50 C. Manufacturers' specifications on this point do not, as a rule, take into account the problems involved when irregular objects are embedded in the resin, but merely refer to the lowest temperature at which a block of polymerized resin will not crack. The presence of objects within the resin, particularly those with sharp corners, will almost always cause cracking at temperatures that the resin alone could withstand safely. Similar troubles are encountered at high temperatures because of the difference in thermal expansion coefficients. These problems are less serious, since the resins tend to soften at elevated temperatures.

Shrinkage of the resin during polymerization is appreciable in many of the resins listed in Table 6-2. Some manufacturers claim that the addition of various fillers, and the use of proper processing, can reduce the shrinkage to zero, if it is found necessary. Various casting resins have values of shrinkage during polymerization, expressed as a percentage of the original volume, ranging from 0.5 percent to 9 percent. A few materials, such as the foaming types of plastics, actually expand on curing. There are indications that low-temperature curing and a longer curing period result in lower shrinkage. Some of the resins listed in Table 6-2 can be cured at room temperature in a reasonable time but, almost invariably, better results are attained by a schedule that includes higher temperatures.

Properties such as noncorrosiveness toward embedded metal parts and good adhesion to metal are possessed by all the resins listed, in greater or lesser degree. Adhesion to metal is very desirable to prevent the entrance of air and moisture, but is somewhat in conflict with the requirement that the resin must not corrode the metal.

In designing a circuit, the dielectric constant of the selected embedment compound must be taken into consideration, as this value varies from resin to resin. This, of course, is an objectionable factor, but the main drawback is that the dissipation factor and dielectric constant of the resins have a definite temperature coefficient, and could thereby make the circuit very temperature-sensitive.

Properties of Ideal Resin. As yet, no casting resin that is ideal for more than one specific application has been developed. Comparatively speaking, however, only a handful of the possible formulations actually have been investigated, and even these are still in the process of full evaluation. Listed below are the principal characteristics that an ideal resin should possess.

1. Low power factor and low dielectric constant at both low and high frequencies.
2. Ability to operate at elevated temperatures, ideally at 200 C or greater, and to withstand high internal hot-spot temperatures.
3. Ability to operate in ambients of -55 C or lower.
4. High thermal conductivity.
5. Low thermal expansion coefficient.
6. Negligible shrinkage during cure.
7. Noncorrosive; no damage to fine copper wire.
8. Excellent adhesion to metals to exclude air and moisture.
9. Low moisture absorption.

10. Simplicity in handling.

11. Low cost.

12. High dielectric strength.

Embedment — Pro and Con. The following lists from a Stanford Research Institute report /20/ attempt to summarize the important positive and negative features of the resin embedment technique as applied to electronic circuits.

#### Positive Features.

1. Gives good protection against moisture, fumes, dirt, and so on.
2. Gives resilient mechanical support to components and tubes, hence good in shock vibration.
3. Eliminates the need for much component mounting hardware.
4. Allows the use of unprotected components, hence tends to reduce cost.
5. Allows components to be compacted together because resin provides electrical insulation and holds positions fixed.
6. Allows three-dimensional circuit construction, with inherent efficiency of space utilization.
7. Prevents unauthorized or unskilled tampering or adjustment in the field.
8. Provides support for sprayed or painted electrical shielding of the embedded circuit.
9. Is relatively cheap.

#### Negative Features.

1. Adds electrical losses to high-frequency circuits.
2. Multiplies stray capacitances by approximately the dielectric constant of the resin.
3. Will not, in general, withstand high temperatures.
4. Will not, in general, readily withstand very low temperatures, particularly when irregularly shaped objects are embedded.
5. Renders replacement of embedded tubes and components difficult or impossible.
6. Adds weight to the assembly.
7. Requires time and labor for preparation of circuits after assembly (cleaning, protecting against shrinkage, and so on).

8. Requires equipment and time for curing, over and above that required for assembly and wiring.

9. Evidence that long term shrinkage (period of years) may be bad in some resins.

Thus, it may be said that since so many different formulations are possible, it is evident that the electronics engineer in this field must work with the close cooperation of the chemist. It is no longer sufficient for the equipment manufacturer only to know something about the use of a melting pot and a few tricks on vacuum impregnation. He must deal with exothermic reactions having critical requirements of catalytic agents, accelerators, inhibitors, curing temperatures and times, fillers, and so on. Small deviations from the optimum values can mean the difference between a usable casting and a complete reject.

#### HERMETIC SEALING

Hermetic sealing was one of the foremost steps taken during World War II to improve electronic equipment reliability. At present, there is considerable activity being devoted to the work of redesigning components in order to seal them against the effects of moisture. In many instances, this work is being carried on in conjunction with miniaturization.

The advantages common to this technique are well appreciated by most design engineers. Among the more important of these are the following.

1. Protection of circuits from fungus, moisture (including actual immersion in water), and corrosive vapors.
2. Protection of circuits from dust and dirt.
3. Protection of circuits from unauthorized and unskilled tampering or servicing.

Hermetic Seal. Though a great many electrical components in use today are sealed, they are not all hermetically sealed. A true hermetic seal is proof against both water and water vapor, and can only be constructed out of metal, glass, or ceramic materials, since these are the only materials that are essentially vaporproof. In general, no organic material can be used for a true hermetic seal. Fused metal joints, soldered glass bushings, or metal bellows arrangements are types of hermetic seal.

This type of seal is meant to be permanent. It should not be frequently broken and resealed in order to have access to internal parts.

It should be appreciated that some rotary waterproof seals may be vaporproof enough to be considered as hermetic seals for considerable lengths of time. An example of this is the lapped disc seal found in refrigerating units. Also, some organic materials have very low vapor transmission rates and, depending upon the equipment, may also be considered hermetic seals.

Table 6-2. Embedment compound characteristics  
(as supplied by the listed companies)

Item	Specific gravity	Heat distortion point ° Centigrade	Dielectric strength (volts per mil)	Dielectric constant vs. frequency (25 C unless noted)	Moisture absorption (by % volume) (unless noted)
Ciba Co. Inc. ARALDITE	1.1 to 1.2	100 to 120	890	50 cps 1 Mc 22 C 3.7 3.6 50 C 3.9 -	1 to 0.14 (168 hrs)
Dow Chemical Co., Inc. STYROFOAM	0.024 to 0.072	79	-	60 cps to 3000 Mc 1.03	<0.03 (80 to 90% Rh, 15 days)
E. I. du Pont Co. TEFLON	2.1 to 2.2	166 (useful at 25)	400 to 500 (80 mil sample 1000 to 2000 65 to 12 mil sample)	100 cps to 100 Mc 2.0	0.005
Emerson & Cuming, Inc. STYCAST TPM	1.05	1.25	450	60 cps to 10,000 Mc 2.36 to 2.38	0.5 (25 C, 24 hrs)
STYCAST 2850 GT	-	175	455	100 cps to 10,000 Mc 4.7	<0.1 (7 days)
STYCAST 35	1.05	85	600 (100 mil sample)	60 cps 1 Kc 1 Mc 1000 Mc 2.596 2.596 2.582 2.584	0.2 (25 C, 24 hrs)
ECCO W 28G Impregnating resin	1.22	approx. 200	412 (1 mil sample)	100 cps to 10,000 Mc approx. 3.4	<0.1 (7 days)
STYCAST 5050 CM	1.7	170	500 (100 mil sample)	100 cps to 1 Mc 4.3	0.10 (25 C, 24 hrs)
M. W. Kellogg Co. KEL-F	2.1	approx. 200	530 (short time test on 1/8 in. sample)  5000 (step-by-step method, 5 mil sample)	1 Kc 1 Mc 100 Mc 2.8 2.5 2.5	Does not absorb or transmit moisture in 3 mil films or greater
Lockheed Aircraft Corp. Rigid Isocyanate LOCKFOAM NO. 2075	0.048 to 0.480	110 to 140	-	10 lb. per cu ft density foam 50 Kc 500 Kc 1 Mc 9.3 Mc 1.22 1.24 1.17 1.19	0.3 to 0.5% by weight (100% Rh, 24 hrs)
Melpar, Inc. MELPAK IV	1.275	> 170	450	4.7 at 8.4 Mc	(24 hrs) 0.034
MELPAK V	1.292	> 200	500	3.6 at 1 Mc	0.30
MELPAK VI	1.480	> 300	475	3.4 at 80 to 120 Mc	0.27

Table 6-2 (cont.). Embedment compound characteristics  
(as supplied by the listed companies)

Power factor vs. frequency (25 C unless noted)	Linear thermal expansion (parts per ° C)	Shrinkage on polymerization (%)	Low temp limit (° C)	Volume resistivity  ohm/cm <sup>3</sup>	Remarks
25 C      50 cps      1 Mc 100 C      0.007      0.027 0.005      0.027	2.5 to 6.0 x 10 <sup>-5</sup>	0.5 to 2.3	-60	10 <sup>16</sup> -10 <sup>17</sup>	Thermal expansion reduced to 2.5 x 10 <sup>-5</sup> by addition of fillers. Adhesion to most metals . . . . . excellent.
1 Kc to 3000 Mc 0.0002	5.4 to 7.2 x 10 <sup>-5</sup>	-	lower than -234	-	Good for many applications up to 2.5 x 10 <sup>4</sup> Mc. Very light, with high strength to weight ratio. Greater strength properties available in lighter density foams.
100 cps to 100 Mc < 0.0005	5.5 x 10 <sup>-5</sup>	-	-268	> 10 <sup>15</sup>	Thermal conductivity 1.7 BTU/hr/sq ft/° F/in. No Solvents.
60 cps to 10,000 Mc 0.0009	5.0 x 10 <sup>-5</sup>	7	-70	> 10 <sup>13</sup>	Low-loss, low dielectric constant, casting resin. Useable over extremely wide temperature range with large inserts.
100 cps to 100 Mc < 0.01 100 Mc to 10,000 Mc < 0.02	1.5 x 10 <sup>-5</sup>	1/2	-75	25 C... 5x10 <sup>16</sup> 150 C... 1x10 <sup>13</sup>	Good high temperature range. Excellent adhesion. Thermal coefficient of expansion similar to brass and aluminum.
60 cps    100 cps    1 Mc    1000 Mc 0.00098   0.00062   0.00084   0.00085	7.0 x 10 <sup>-5</sup>	10	-20	10 <sup>14</sup>	Excellent machinability
100 cps to 10,000 Mc < 0.02	5.0 x 10 <sup>-5</sup>	4	-	2.3 x 10 <sup>16</sup>	Impregnant for transformers, coils, capacitors. Can be used as casting resin.
100 cps    1 to 10 Kc    100 Kc    1 Mc 0.015      0.040      0.030    0.019	5.5 x 10 <sup>-5</sup>	5	-65	10 <sup>12</sup>	Black, opaque material
1 Kc      1 Mc      100 Mc 0.025      0.008      0.006  (power factor lower at 200 C than at 25 C)	-80 to +20 4.5 x 10 <sup>-5</sup>  20 to 150 7 x 10 <sup>-5</sup>	0.005 to 0.010 per in.	-201	1.2 x 10 <sup>18</sup> (50% Rh, 25 C)	Chemically inert, high impact, high-temperature material. Excellent electrical properties over wide temperature range. Can be injection extrusion, transfer, or compression molded.
5 x 10 <sup>-5</sup> at 9300 Mc	3 x 10 <sup>-5</sup>	negligible	unaffected at -73.5	-	Density may be controlled from 1 to 40 lb per cu ft. Can be poured and formed in place at 21.1 C to 26.7 C.
0.62 at 34 Mc	2.5 x 10 <sup>-5</sup>	6 to 8	-65	10 <sup>15</sup>	Hot spot temperature. Should be 170 C or less. Can be cured at room temperature, but higher temperatures preferable.
0.015 at 1 Mc	3.0 x 10 <sup>-5</sup>	2 to 3	-65	10 <sup>17</sup>	-
0.016 at 60 cps	2.5 x 10 <sup>-5</sup>	4 to 5	-65	10 <sup>15</sup>	-

Table 6-2 (cont.). Embedment compound characteristics  
(as supplied by the listed companies)

Item	Specific gravity	Heat distortion point Centigrade	Dielectric strength (volts per mil)	Dielectric constant vs. frequency (25 C unless noted)	Moisture absorption (by % volume) (unless noted)
Diamond Ordnance Laboratories NBS RESIN	1.22	68 to 70	610 to 660	100 cps 10 Kc 1 Mc 100 Mc 2.44 2.43 2.42 2.5	(24 hrs) 0.01
FN-2.5 CASTING RESIN	1.06	51	—	100 cps to 1 Mc 100 Mc 2.61 2.60	0.02
U. S. Navy Electronics Laboratories N. E. L. 177	1.235	> 85 (passes spec 16 E 4)	700 (30 mil sample, 60% Rh, 22.2 C)	100 cps 100 Kc 60 Mc 3.20 3.26 3.09 (62% Rh, 23.3 C)	0.23
Pittsburgh Plate Glass Co. SELECTRON 5000-5199	1.2 - 1.4	45 to 200	(Short time test, 1/8 in. specimen) 400 to 600	(1/8 in. specimen) 60 cps 1 Kc 1 Mc 3.30 to 3.70 3.10 to 3.30 3.00 to 3.25	(24 hrs) 0.05 to 0.5
SELECTRON 5003	1.22	90	480	3.55 3.15 3.08	0.3
SELECTRON 5200-5399	1.15	—	300 to 500	6.00 to 6.40 5.10 to 5.50 3.60 to 5.00	0.5 to 1.0
H. H. Robertson Co. STYPOL 107E	1.253	56	(1/8 in. sheet) 365	60 cps 1 Kc 1 Mc 3.86 3.59 3.35	(24 hrs) 0.27
STYPOL 502E	1.540	—	336	5.53 5.10 4.23	0.30
STYPOL 507E	1.551 (Solid resin at 25 C)	55	378	4.57 4.15 3.74	0.14
Rohm & Haas Co. PARAPLEX P-13	1.122 (at 25 C)	—	(100 mil casting at 25 C) 345	60 cps to 1 Kc 1 Mc 10 Mc 30 Mc 4.2 4.0 3.7 3.4	(% wt, 24 hrs, 25 C) 0.6  (% wt, 24 hrs, 25 C) 2.0
PARAPLEX P-43	1.235	75 to 85 (2 C per min at 264 psi)	500	60 cps 1 Kc to 10 Mc 30 Mc 10,000 Mc 3.3 3.2 3.1 2.6	(% wt, 24 hrs, 25 C) 0.3  (% wt, 24 hrs, 100 C) 3.0

Table 6-2 (cont.). Embedment compound characteristics  
(as supplied by the listed companies)

Power factor vs. frequency (25 C unless noted)	Linear thermal expansion (parts per ° C)	Shrinkage on polymerization (%)	Low temp limit (° C)	Volume resistivity ohm/cm <sup>3</sup>	Remarks
100 Mc 0.0004 to 0.0008	11 x 10 <sup>-5</sup>	7.5	-55 (cracks at this temp)	10 <sup>17</sup>	Specialized resin for UHF high impedance circuits. Quite expensive to manufacture.
100 cps      10 Kc      1 Mc      100 Mc 0.0016      0.0010      0.0009      0.0010	-	9.8	-	10 <sup>17</sup>	A copolymer of styrene and fumarionitrile. Uses similar to NBS CASTING RESIN; less expensive but some sacrifice in dissipation factor at elevated temperatures.
100 cps      100 Kc      60 Mc 0.0173      0.0156      0.0234 (62% Rh, 23.3 C)	6.01 x 10 <sup>-5</sup>	-	-54	9 x 10 <sup>12</sup> (60% Rh, 24.4 C)	Preliminary data only.
(1/8 in. specimen) 60 cps      1 Kc      1 Mc 0.016 to 0.02      0.003 to 0.01      0.008 to 0.015	-	6 to 9	-55	-	Rigid resins with widely varying properties.
60 cps      1 Kc      1 Mc 0.017      0.0036      0.013	8 to 10 x 10 <sup>-5</sup>	7.5	-55	-	General purpose casting resin.
0.13 to 0.15      0.04 to 0.06      0.015 to 0.05	-	6 to 9	-	-	Flexible resins that may be blended with resins.
60 cps      1 Kc      1 Mc 0.016      0.0079      0.024	-	8.7	-	-	For impregnating transformers.
0.069      0.072      0.049	-	8.4	-55	-	Inorganic filler provides increased resistance to crack- ing - higher thermal conduc- tivity
0.022      0.013      0.025	-	8.9	-	-	Harder, more rigid than 502E. Also has inorganic filler.
60 cps      1 Kc      1 Mc 0.005      0.011      0.052  10 Mc      30 Mc 0.080      0.105	-	9.0	-	-	Flexible polymer. Can be mixed to obtain intermediate properties.
60 cps to 1 Kc      1 Mc      10 Mc 0.006      0.017      0.022  30 Mc      10,000 Mc 0.034      0.043	-	7.0	-	-	Rigid polymer. Can be mixed to obtain intermediate properties.



Waterproof Seal. A waterproof seal constitutes the general practice in sealing and in gasketing. This seal is only proof against gross water and is only moderately vaporproof. Common types are anic packing, O-rings, rubber gaskets, and lapped disc seals.

Design Considerations of Hermetic Sealing. Supplementing American experience, the British have performed some interesting laboratory tests. Hermetic sealing of a particular equipment reduced the number of failures in a service acceptance test to approximately 11 percent of the number occurring in unsealed equipment of the same type. In general, the British laboratories now tend to prefer the individual sealing of subassemblies. Overall package sealing has also been applied to complex assemblies in this country, but the application of hermetic sealing to subassemblies of one sort or another is much more common. To date, hermetic sealing has been especially successful when applied to transformers, reactors, and capacitors, and more recently has been adopted for such components as relays and switches.

In applying hermetic sealing, care must be exercised to see that the seal is absolute and permanent for all conditions to which the unit will be exposed. A partial seal on a unit that contains some free space will be susceptible to "breathing," and moisture vapor will condense and accumulate in the air space. If the space is small, it may be possible to prevent "breathing" by filling it with a good casting resin, provided the unit is not damaged thereby or its function impaired. Good design practice sometimes requires the use of liquids to aid in the transfer of heat to the exterior. If it is not expedient to use a solid or liquid, an inert gas may be substituted for air. The gas will not aid any corrosion process, and its pressure will help support the case from the effects of external atmospheric pressure.

A Stanford Research Institute publication /20/ gives an excellent review of the relative merits of overall sealing and subassembly sealing. Overall package sealing simplifies the problem of adequate hermetic sealing to the extent that there is only one large seal to be made, and all components are protected by it. On the negative side, however, overall sealing prevents easy access for servicing by requiring the entire equipment to be opened, with consequent loss of inert gases and possible entrance of moisture. Subassembly sealing has the primary advantage of allowing easy replacement of the sealed units, particularly if they are made to plug in. But a great deal of trouble should be taken to prevent fungus, humidity, and so on, from acting on the plugs, sockets, and wiring necessary for interconnecting the plug-in units. The individual assemblies will also tend to be more expensive than an overall sealed package, and may also be heavier. The choice between the two sealing systems may well depend on the relative importance of long life, accompanied by regular maintenance procedures, vs. short life with little, if any, maintenance. The latter category would include such expendable equipments as guided missiles, sonobuoys, VT fuses, and other devices of similar nature. Overall sealed packaging applies almost ideally in such

cases. Examples of equipments falling in the first category would be such devices as shipborne or land-based radar and communication gear. Here, the life expectancy is measured in thousands of hours, and considerable maintenance is ordinarily anticipated. Airborne equipment is an intermediate case that often uses overall sealing to advantage because no maintenance can be performed in flight.

Table 6-3 contains a qualitative comparison of a number of hermetic sealing techniques. These comparisons are based largely on experience reported by the various organizations active in their use.

Application of Gas Filling. In a fairly large class of electronic circuits, the dielectric losses and increased capacitance associated with either resin embedment or fluid filling are not tolerable. Typical examples of such circuits are r-f, i-f, and video frequency amplifiers, which approach the ultimate in gain-bandwidth product of the tubes used. A loss in gain-bandwidth product could be made up by increasing the number of stages. This, however, is generally undesirable, particularly when space requirements are important. Such circuits are often packaged by placing them in a sealed container filled with a dry, inert gas at atmospheric pressure. A somewhat less desirable way of packaging is to fill the container with dry air and then seal it to prevent the entrance of moisture. The condensation of moisture in an air-filled unit is often inhibited by including some form of chemical desiccant, packaged in such a way as to be readily renewable. Both here and abroad, gas filling has been used to good advantage.

The following lists sum up what appear to be the positive and negative features of gas filling applied to electronic assemblies.

#### Positive Features.

1. Adds no losses to the circuit.
2. Does not increase the stray circuit capacitances.
3. Imposes no limitations on operating temperatures (circuit components and tubes determine temperatures).
4. Permits inclusion of moving part components.
5. Prevents oxidation of lubricants in moving assemblies.
6. Reduces arcing of relays, switches, and other current-interrupting devices.
7. Reduces oxidation of commutators, switch contacts, and so on.
8. Permits servicing where container may be opened.
9. Provides gas convection cooling — better than most resin embedments.

Table 6-3. Relative merits of hermetic sealing techniques

Technique	Mechan. rigidity	Temp. resist.		Heat transfer	Effective dielectric constant*	Losses at high freq.	Humid. protect.	Ease of service
		High	Low					
Resin embedment	E	P	P to F	P	2.5 to 4.0	P to G	E	P
Foam embedment	G	P	F	P	1.03 to 1.2	G	G	P
Ceramic embedment	E	E	E	F	10	F to G	E	F
Plastic coating	P to F	P	F	P to F	1.0	G to E	F to G	F to G
Silicone film	P to F	G	G	P to F	1.0	G to E	G	G
Silicone fluid filling	P	G	F to G	F to G	2.5 to 3.5	G to E	E	F
Gas filling	P	E	E	F	1.0	E	G to E	F to G

E = Excellent

G = Good

F = Fair

P = Poor

\* Circuit stray capacitances are increased by approximately this factor.

Negative Features.

1. Provides no mechanical support to contained elements against vibration and shock.
2. Requires a container strong enough to withstand the internal pressure when it is intended for high-altitude operation.
3. Requires a controlled atmosphere for servicing or drying facilities for both equipment and gas.
4. Cooling provided for the circuit is somewhat poorer than for liquid filling.
5. Difficult to detect the presence of a leak once the equipment is sealed off.

Fluid Filling. Oil filling of encased electrical components has been standard practice for years, particularly in the power industry, where long life and trouble-free operation are extremely important. With this precedent established, it is only natural that attention has been turned to the use of insulating fluids for filling hermetically sealed electronic assemblies in which reliability is highly desirable, too. The development of silicone fluids with excellent electrical and physical characteristics has made fluid filling even more attractive for circuits operating at power levels that preclude the use of resin embedment and require better insulation and

cooling than is afforded by gas filling. At present, a few organizations are using fluid filling of electronic assemblies.

Listed below are the desirable characteristics that a liquid dielectric should possess for use in sealed electronic equipment.

1. Low vapor pressure
2. Low thermal coefficient of expansion
3. Low viscosity
4. Low thermal coefficient of viscosity
5. Low surface tension
6. Nonhygroscopic
7. High thermal conductivity
8. Inertness toward commonly used metals and insulating materials
9. No tendency to oxidize or sludge
10. Low dielectric constant
11. Low power factor
12. High dielectric strength.

There are a number of liquid dielectrics that have been used in both power and communication transformers, chokes, condensers, and other high-voltage and/or heavy-duty components and assemblies. For the most part, these fluids are hydrocarbons of one form or another, and suffer from such defects as high dielectric constant, high power factor (particularly at radio frequencies), and inability to withstand very low or very high temperatures.

The physical properties of silicone fluids are remarkably good, particularly as regards ability to operate at low temperatures (-40 C to -55 C, depending on viscosity) and at high temperatures (at least 200 C for viscosities above 50 centistokes). At the time of this writing, more data were available for the newer silicone fluids than for the older, well-known liquid dielectrics. The reader should bear this in mind when reading the following sections.

Silicone fluids are available in a wide range of viscosities, and the electrical characteristics of several are listed in Table 6-4, together with a number of the standard liquids. It will be noted that the dielectric constant and power factor are good up to at least 100 Mc. The dielectric constant decreases slightly with increasing temperatures, while the power factor increases as may be expected. The changes in neither parameter are large enough to cause much concern in the majority of applications. For example, 500 centistoke fluid changes its power factor from 0.000025 to 0.0003 in going from 25 C to 150 C at a particular frequency.

The use of fluid filling in packaging electronic assemblies is accompanied by a number of advantages and disadvantages, some of which are listed below.

#### Positive Features.

1. Allows a greater degree of miniaturization because of improved cooling.
2. Increases voltage ratings because of high dielectric strength of fluids.
3. Allows the use of unprotected, uncased components.

#### Negative Features.

1. Requires mounting hardware for components, as contrasted with resin embedment.
2. Requires that containers have pressure relief provision.
3. A leak in the container may disable the the unit, and is messy at best.
4. Difficult to repair.
5. Cooling effectiveness decreases with decreasing temperature (viscosity increases).

6. Some fluids are solvents for certain insulating materials.
7. Stray capacitances are multiplied by dielectric constant of fluid.
8. Losses are increased in proportion to the power factor of the fluid.

Conclusion. In conclusion, it should be said that hermetic sealing must not be thought of as a cure-all for the troubles currently facing electronics designers. The practice of sealing field equipment will reduce, but not eliminate, the need for regular maintenance; sealing techniques must be applied with discretion, so that they do not become a hindrance to field adjustment and repair. In field operations, replacement is usually the only practical measure, while the actual repair work is performed at a higher echelon. A general rule that should be followed is to limit sealing to expendable individual components or relatively small assemblies that may easily be replaced. In the future, when the reliability of components warrants such action, sealing of entire equipments may be both feasible and advisable.

#### MOISTURE AND ITS EFFECT ON EQUIPMENT

Complete statistics are not available, but it is a well-documented fact that one of the most serious problems facing our military Services in World War II was the deteriorating effect of moisture on electronic equipment. In reviewing this problem, it is pointed out that the sensitivity and range of signal equipment were impaired because moisture had altered the electrical constants of its tuned circuits./2/ Component parts failed and insulation broke down with alarming speed.

The rupture of organic insulation was common; switches, relays, meters, and other metal parts corroded, and favorable conditions were provided for the growth of fungus. Moisture, in fact, is one of nature's most "secret" weapons, for it tends to reduce all of man's buildings to the dust out of which they were made.

The amount of moisture present on a surface is dependent upon the relative humidity and the ease with which water wets that surface. Surfaces rapidly become wet when the relative humidity is high. According to Field, /21/ an ionized conducting film of water will form on the surface of a dielectric within a few seconds, if the relative humidity of the atmosphere is 100 percent. Only a few materials, such as wax, polystyrene, the silicones, and some other polymers, can successfully stop the formation of a continuous moisture film, whereas such a film easily forms on quartz, glass, and the steatite porcelains.

The presence of moisture on the surface of an insulating material reduces the surface resistivity of that material. By seeping into the interior of a porous insulator, moisture reduces its volume resistivity. The rate at which moisture permeates a material is dependent upon the water content of the surrounding atmosphere, the transmission rate of water vapor on the surface of the material, and the hygroscopicity of

Table 6-4. Properties of liquid dielectrics\*

Silicone Fluids	Specific gravity	Flash point (° C)	Dielectric strengths (volts per mil)	Dielectric constant (at 25 C)	Power factor	Heat transmission gram cal/sec/cm <sup>2</sup> /° C/cm.	Remarks
25 C. 3 Centistokes	0.896	107	250 (0.1 in. sample)	100 cps - 2.412 1 Mc - 2.405 100 Mc - 2.39	100 cps - 0.0001 1 Mc - 0.0002 100 Mc - 0.0002	0.00027 0.00027	Liquid methyl silicones. Volatile liquid. Useful to -55 C.
25 C. 350 Centistokes	0.972	315	250 (0.1 in. sample)	100 cps - 2.74 1 Mc - 2.72 100 Mc - 270	100 cps - 0.0001 1 Mc - 0.0002 100 Mc - 0.0006	0.00039	Nonvolatile fluid. Useful -40 C to +200C.
25 C. 550 Centistokes	1.08 (25 C)	315	350 (0.1 in. sample)	100 cps - 2.92 1 Kc - 2.91 100 Kc - 2.91	100 cps - 0.0001 1 Kc - 0.0001 100 Kc - 0.0001	--	Liquid phenyl-methyl silicone of exceptional heat stability. Useful -40 C to +250 C.
25 C. 1000 Centistokes	0.973	315	300 (0.1 in. sample)	100 cps - 2.78 1 Mc - 2.78 3000 Mc - 2.74	100 cps - 0.0001 1 Mc - 0.0003 3000 Mc - 0.0096	0.0038	Nonvolatile fluid useful from -40 C to +200 C.

\* Courtesy Dow Chemical Corporation. Other silicone fluids are obtainable from other manufacturers but because of different methods and conditions of measurements, their data are not presented here. The figures given above are characteristic of the silicones as a group.

the material. The majority of the glasses, the vitrified ceramics, polystyrene, polyethylene, and a few of the other polymers do not readily absorb water. The cellulose materials are the least water resistant of the plastics.

It is generally known that the absorption of moisture by solid insulating materials increases their permittivities because water has a dielectric constant of 80. This is high for most insulating materials; that for mica is around 6, while that for bakelite is 4.5. The presence of water on the surface and within a dielectric increases its capacitance. The absorption of water also causes an increase in the dissipation factor — possibly to the point where thermal breakdown of the material occurs.

**Condensation.** In the tropics, with their severe humid conditions, moisture readily condenses within equipment during the night. Heavy deposits of moisture are left on surfaces, and the moisture absorption of critical materials is greatly increased. Electrical discharge between high-tension points is more likely to occur during periods of condensation, unless the intermediate insulation is of a nonwetting type. DeLerno /22/ found that condensed moisture on the surfaces of Textolite lowered its breakdown voltage by about 25 percent at sea level pressure, but

the formation of frozen water on this surface and the percentage of the relative humidity at the time appeared to have no effect. If arc-over follows the initial spark discharge, permanent damage to the insulation is likely to occur. The surfaces of phenolics and similar materials can "char" or "carbonize" until sufficient carbon has been formed to carry the current./23/ Noncarbonizing materials may also be affected. If the spark discharges are of sufficient intensity, these materials tend to fuse along the discharge path and give rise to an increase in electrical conductivity. Arc-over has also been found responsible for the deposition of metallic materials from the electrodes onto the surfaces of ceramics.

**Breathing.** Another type of damage that flourishes under humid conditions is termed "breathing" because of its similarity with the natural living process. It is a cycling procedure by which water gradually accumulates in partially-sealed containers. The air in such containers becomes warm during the day, and a portion is forced out as it expands. At night, as the temperature drops, heavier air having a moisture content near the saturation point flows back in. Further lowering of the temperature then causes condensation. Not all of the moisture added during the intake period is expelled during outflow, and a net increase of water is added with each cycle.

Therefore, during the preliminary design stages, consideration must be given to ventilation and the elimination of moisture traps.

**Biological Growth and Its Effect on Equipment.** As previously stated, the continuously high humidities prevailing in most of the tropical jungle regions of the South Pacific were held most accountable for the rampant deterioration of equipment during World War II, but the combination of high humidity and favorable temperatures also presented optimum living conditions for destructive fungi./24/ The interiors of electronic equipments became covered with a network of fungi. Insulating materials that contained cellulose derivatives were most susceptible to fungus attack, but fungi were also found on inorganic as well as on organic insulation — in fact, on any surface where suitable debris might accumulate. Such organisms even grew on metal surfaces and on the windows of indicating instruments.

When the seriousness of the situation was fully appreciated, various measures, which have come to be known as "Tropicalization," were instituted to protect both new equipment and equipment already in the field. The best known single step taken in this program was the overall treatment of radio and radar equipment with a varnish or lacquer to which a fungicide had been added. This coating was intended to provide protection from fungus growth, moisture, corrosion, salt spray, and insects. After an assembly had been given this treatment, it was stamped with the letters MFP (Moisture-Fungus-Proofed).

There has been considerable controversy as to whether or not the damage to insulating materials and components in humid environments is almost wholly due to moisture. Moisture infiltration in electrical insulation is not easy to detect by visual examination, unless the effects are so great that the material shows signs of either mechanical disintegration or visible fungus growth on the surface. The presence of fungi is good evidence that the equipment has been exposed to high humidities. Although the climatic conditions in the tropics are most favorable to the life processes of fungi, the colder middle latitudes also support fungus growth, if the humidity is high; this growth has even appeared on electronic equipment in the Aleutian Islands. For these reasons, the failure of equipment has generally been associated with the conspicuous, and sometimes casual, evidence that it was "full of fungus." The extent of fungus growth in equipment has often been considered to be a measure of the extent of deterioration, and the fungus itself to be a prime deteriorating factor.

As early as 1944, Leutritz and Herrman studied the effects of high humidity and fungus growth on unfilled and various filled plastics./25/ The results of these tests indicated that the insulation resistance of the common commercial types of insulating materials made from organic and inorganic filled plastics may be so rapidly affected by water absorption and condensation that any adverse effect by fungus growth is negligible.

Witt /26/ made a comprehensive study of representative plastic materials to determine the effect of moisture and fungi on their mechanical and electrical properties. All samples were exposed to high humidities. They were inoculated with fungus spores and tested under aerobic conditions. About half the samples of this group showed no visual growth. Copious growth was observed only on cotton fabric-reinforced phenolic laminates. The fungi did not penetrate the materials, but were confined to the surfaces and cut edges. Even on samples where fungus growth was plainly visible, it did not prove to be a decisive factor in the deterioration of electrical or mechanical properties. Some of the tests performed were not critically dependent upon surface growth of fungi, but the effects of moisture were so great that they masked any effect of the biological agent alone.

By means of fumigating vapors, Luce and Mathes /27/ have achieved the most definitive separation of the relative effects of moisture and fungi that has as yet appeared in studies of the surface and leakage resistance of hook-up wire. They found that braided wire insulation possesses such poor surface resistivity under conditions of high humidity that fungus growth did not further degrade its electrical characteristics. Surface and creepage resistances fell from the order of between 1,000 and 1,000,000 megohms to 0.1 megohm and less, even when some of the wires were in an atmosphere of methyl bromide or other fumigating vapors. On the other hand, the superior electrical characteristics of unbraided wire insulation were markedly deteriorated by fungus growth. The surface and leakage resistance of unbraided wire insulation dropped rapidly from almost infinite resistance (1,000,000 megohms) to values of 5 megohms and less under conditions of 100 percent relative humidity with dew and inoculation with fungi. Wires exposed to this same humidity, but in an atmosphere of methyl bromide, tended to maintain their initial resistance values for test periods up to 60 days. The deleterious effects could be measured before fungus growth was visible and even when visible growth was never observed. Surface deterioration caused by fungus growth thus is severe enough to compromise the superior electrical characteristics of unbraided wire insulation.

To provide an environment where materials and equipments may be exposed to a tropical environment, which is a close approximation of the conditions that exist in service, the Naval Research Laboratory operates a tropical exposure site in the Panama Canal Zone./28/ An experiment was conducted at this site on 18 Navy communications receivers to evaluate the MFP treatment. The equipment, built of components of varying quality (some coated, some uncoated), was exposed for almost four years in a Quonset hut at the edge of the jungle. Sensitivity measurements were taken and regular maintenance operations performed, so that receivers were realigned and defective component parts replaced whenever necessary. Of the conclusions drawn from the test, two are of particular importance.

1. None of the receivers, not even those built with higher quality components, was

capable of withstanding prolonged exposure without functional impairment, component part failure, or both.

2. The MFP treatment apparently made no contribution either to the operability or to the service life of the receivers (both high and low quality).

The first conclusion disproves the belief, held by some, that with the use of improved materials and component parts, the problem of climatic deterioration is solved. There was no doubt that the MFP treatment did retard metallic corrosion and inhibit fungus growth. The results, however, were not reflected in improved receiver performance. This seems to be in keeping with previous findings on the subordinate role of fungus in the impairment of electrical resistance. The second conclusion can be taken as a strong indictment of the MFP treatment and its use as a remedy for the shortcomings of low-quality component parts.

Finally, a word may be said with respect to some practical aspects of the problem of biological growth. It has been observed that equipment in the field that has become overgrown with fungi may be promptly discarded without any attempt to check its level of performance. Aside from the influence of fungus growth on the performance of equipment, there are the psychological effects upon the personnel who operate it. The presence of such growth leads the operator to suspect that his equipment is in a degraded condition and may not function properly, especially when it may be most needed. Such a situation tends to lower his morale and affect his efficiency.

Protection from Moisture and Biological Growth. The decline in both electrical and mechanical properties of insulating materials in humid environments has been referred to several times. Some of the insulating materials have high resistance to the effects of moisture and fungi, but are unsuitable in many applications for other reasons./2/ For instance, the electrical types of thermoplastics are relatively impermeable to moisture, but have low heat-distortion temperatures. Vitrified ceramics have low moisture permeability, but they are brittle and susceptible to thermal shock. On the other hand, some materials that are affected by moisture, such as the paper-base phenolics, are selected when mechanical properties and adaptability must be combined with good electrical properties. Sometimes even cotton-based materials are used when strength is important and electrical properties are not critical. If vulnerable materials are used, they must be given special protection from the effects of moisture and fungi.

The best way to improve the structure of laminated or molded plastic materials is to impregnate them with a hydrocarbon wax or varnish. This can be made more effective if the parts to be treated are pressure-impregnated by placing them in a vacuum chamber and admitting wax or varnish after the chamber has been sufficiently evacuated.

If the impregnation treatment is impractical, one or more coats of varnish or lacquer may be applied by brushing, spraying, or dipping, each coat being baked for complete curing.

The presence of fungus growth often accompanies a sustained high-moisture content. Plastics with low moisture-absorbing tendencies are, therefore, additionally preferred for many electrical applications because their surfaces are less hospitable to the growth of organisms. Materials that are nutrient to fungi should, of course, be avoided whenever possible. Among the "pure" plastics that support fungus growth are cellulose nitrate, melamine formaldehyde, and vinyl acetate. If a plastic happens to be modified material, its susceptibility to fungus is often unpredictable; some formulations may support fungus growth and others may not. Often, this disparity can be accounted for by the particular ingredients present in the formulation, as some of these have been found to be nutrient to fungi. It has been found that some of the phthalates support the growth of organisms, although many of them do not. In general, plasticizers of the long-chain fatty-ester type, such as stearates, sebacates, oleates, and ricinoleates, should be avoided if other, more critical properties are not compromised by so doing.

Realizing that the fungus resistance of many good synthetics was compromised by their plasticizers, the Naval Research Laboratory undertook a survey of the fungus susceptibilities of a large number of plasticizers./29/ Though a limited number of materials were studied, the results do provide a useful compendium (see Table 6-5).

From the test, it was noted that the most susceptible plasticizers tested were the natural oils and the esters of naturally occurring fatty acids. Synthetic products, having no chemical relationship to natural oils, are generally satisfactory.

To prevent the growth of fungus on plastics, an attempt has been made to incorporate fungicides into the plastic structure — either into the resin, the filler, or the modifying additives — but this has been unsatisfactory. The molding temperatures required in the thermosetting types of plastics are above the decomposition points of the efficient toxics. The fungicides, moreover, are pores, and unless the agent is effective in extremely small quantities, the chemical structure contributes to a decline in electrical properties. In optical grades of thermoplastics, the addition of fungicides is apt to cause color changes and blurring.

The addition of an established fungicide to a varnish or lacquer does not always ensure that the coating will have fungicidal activity. It has been noted in varnishes containing modified alkyd and phenolic resins that some of the fungicides are deactivated and their effectiveness reduced either by the pronounced sealing action of the coatings or by some interaction between gas fungicide and coating. A good coating must be relatively permeable. Therefore, the value of the added toxants is questionable, since they can be expected to be sealed within the film. Leonard and

Table 6-5. Fungus growth on plasticizers

Plasticizer	Extent of growth*
Castor oil	++++
Glyceryl laurates	++++
Sorbitol laurate	++++
Triethanolamine dicaprylate	++++
Dibutyl sebacate	+++
Dibutyl phthalate	-
Diethyl phthalate	-
Tricresyl phosphate	+
Di-(o-xenyl) monophenyl phosphate	-
Butylphthalylbutyl glycolate	+
Ethylene glycol monoethyl ether laurate	++++
Triethylene glycol di-2-ethyl benzoate	-
Tetraethylene glycol distearate	++++
Silicone oil	-

\*Key:  
 - no growth on sample  
 + growth discernible with 20 X magnification, not visible to naked eye  
 ++ sparse growth but easily visible  
 +++ moderate growth  
 ++++ heavy growth

others found that when chemicals with fungicidal properties were incorporated into varnishes and lacquers, the resulting combinations did not exhibit the fungicidal tendencies expected./29/

Seldom does the designer, or electrical manufacturer, for that matter, know the complete composition of a material or fabricated article that he proposes to use. As such, he can seldom say in advance that a particular material or item will prove satisfactory merely because it contains nothing that is hygroscopic or fungus-susceptible. More often, he is in a position to reject a certain material because he knows it to contain a natural product (or something closely related) that makes its fungus or moisture resistance highly questionable.

The A. A. No. 4 Mk. 6 Radar. Dissatisfied with the tropical performance of some of its radar equipment during World War II, Canada set out to determine the requirements imposed by operation in this environment./30/ These factors, once determined, would then be incorporated in future designs. As a result of subsequent investigations, steps were taken to tropicalize the A. A. No. 4 Mk. 6 Radar, and to date, the reliability of this equipment is excellent.

An initial decision was made that any and all "tropic-proof" methods were stopgap measures, used only when necessary with inferior component parts and materials. In other words, tropicalizing should not be necessary, since a properly designed radar should perform well under all conditions. With this in mind, the following requirements were set forth.

1. Only the best quality component parts are to be used.

2. Component parts not presently available in hermetically sealed form are to be treated by the manufacturer to render them fully moisture-resistant.
3. If deemed necessary by the designers, component parts shall be derated to forestall failure under conditions of high ambient temperature.
4. Organic materials, such as fabrics, canvas, and string, shall not be used, as they are susceptible to moisture absorption, rot, and fungus growth. Metal-cased, sealed units shall be used instead of waxed component parts. Leather shall be used only if properly treated to prevent mould growth.
5. Care shall be exerted in mounting component parts, so that moisture traps are not present.
6. Completed chassis shall be painted or sprayed with an approved moisture-resistant, air-drying varnish, after which a coat of approved fungicidal varnish shall be applied.
7. Cable assemblies shall be dipped in fungicidal varnish, before installation, to inhibit fungus growth.
8. Metal surfaces shall be adequately treated to prevent corrosion. Special consideration shall be given to all intermetallic contacts to prevent corrosion resulting from electrolytic action. Care shall be taken that no dissimilar metals whose potential difference exceeds 0.5 volts are in direct contact.
9. Any wood that is required shall have been treated to resist rot and mould growth.
10. Where possible, spare parts shall be shipped in moistureproofed standard containers. Before packaging, mechanical spares shall be treated with corrosion-inhibiting greases or special resins, which can be peeled off before the part is put into service.

These principles are essential for tropical equipment. They are not entirely sufficient, however, since they do not take into account special conditions arising during operation of the equipment. These special conditions were met by the following procedures.

1. A dehumidifying unit, capable of maintaining the relative humidity below 50 percent, was made an integral part of the trailer. However, for reasons of health, the temperature differential between inside and outside was confined to only 7 F. As high humidity is one of the most frequent

causes of component part failure, this unit provided improved operating conditions and helped prevent component part breakdown.

2. When the radar was shut off, heaters located throughout the equipment were automatically turned on, and with the aid of forced ventilation, the whole equipment was kept relatively warm. This had two advantages; it reduced thermal shock and eliminated moisture condensation during nonoperating periods.

## SALT SPRAY EFFECTS

Equipment located along coasts or beaches suffered severely from the effects of salt spray during World War II because salt atmosphere produces heavy corrosion of metals./2/ Though this problem was most acute with equipment located on shipboard or in coastal installations, it also affected radio and radar installations located considerable distances from the coast, since the wind is capable of carrying large quantities of salt particles from the oceanspray great distances inland. Cadmium and zinc coatings, which had been considered adequate to protect iron and steel, failed badly./31/ The corrosion products of these platings caused short circuits between terminals on the insulating boards of electronic equipment. Commercial copper also corroded in these locations, and even silver plating was not immune. Switches, relays, meters, and rotating parts became corroded, and their reliability was impaired.

Corrosion. Corrosion results from an electrochemical reaction involving dissimilar metals exposed to an electrolyte. One of the electrolytes most frequently found in marine atmospheres is ordinary salt sea air, which settles on equipment from spray or mist. Corrosion is rarely a single process. In other words, atmospheric and fresh or sea water corrosion may be attacking metal simultaneously with galvanic, concentration-cell, stress, and fretting corrosion. These actions are affected in turn by such factors as the acidity, oxidation, temperature, agitation, and impurities in the corrosive solutions. Other factors, such as surface conditions, stress, heat treatment, joining of dissimilar metals, and methods of fabrication, also affect corrosion rates.

Protection of Metal Surfaces. Little was known prior to World War II of the severely corrosive atmospheres prevailing in some parts of the tropics. Electronic equipment was designed primarily for service indoors, and finishes were generally chosen to improve appearance rather than to protect against corrosion. Salt-spray tests were sometimes specified, but these tests did not duplicate the environmental conditions met in many tropical locations. In an attempt to correlate the results of tropical exposure with laboratory tests, several of the Services have developed high-humidity temperature cycles, and equipments are required to pass certain humidity tests before they are approved. Today, many difficulties are being discovered and corrected in the laboratory, thus preventing failure in the field.

Aluminum. Aluminum is fairly resistant to corrosion and is additionally desirable because of its lightness. The aluminum alloys 2S, 3S, 52S, 53S, and 61S, and alloys clad with one of these, are corrosion resistant, but if the aluminum is to be exposed to severe corrosive conditions, the surface should be treated so that a nonreactive coating is formed on the basis metal. A number of standard treatments are in use.

Magnesium. Magnesium is the lightest metal available for engineering purposes, and it is used as far as possible where weight limitations are critical. Several chemical treatments have been devised for protecting magnesium. All alloys, except the manganese-magnesium alloys (type M), may be given long-term protection with the widely used dichromate treatment. The sealed chrome pickle treatment is satisfactory for the manganese alloys, except where close dimensional tolerances are required, for which an anodizing treatment is preferred.

Since magnesium is the least noble of the structural metals, it is extremely susceptible to electrolytic processes when in contact with another metal. Extreme vigilance must be exercised to prevent such contact, especially with metals that are notably lower in potential, such as copper and the ferrous alloys. In general, the high potential of magnesium renders it unfavorable for electronic use.

Copper. Copper and its alloys serve a variety of functions in electrical and electronic equipment. Copper is ordinarily quite resistant to atmospheric corrosion, but this resistance seems to depend on its purity, since commercial grades of copper were found to corrode in tropical climates./2/ It may be plated with nickel, chromium, or tin for increased protection, although a tin plating is damaged more easily than the others. A good, durable chemical treatment for copper alloys consists of converting the surface to black cupric oxide and supplementing this treatment with a coat of lacquer when desired.

Because of their low position in the electrochemical series, copper alloys are not attacked to any extent when in contact with other metals, but they must be insulated from magnesium, zinc, and cadmium, so as not to initiate electrolytic attack on this latter group of metals.

Iron and Steel. Iron and steel are used in the construction of numerous components, partly because of their magnetic properties. Nickel and chromium platings impart corrosion resistance to iron and steel. In addition, the final flash coating of chromium prevents the tarnishing of the nickel and gives an attractive finish. Electroplating of these two metals, however, is porous, and since they are cathodic to iron and steel, they tend to stimulate corrosion of iron and steel. This may be prevented by using heavy platings over 1 mil thick, as there is little porosity in platings of this thickness. If thin nickel platings are used, the difficulties caused by porosity may be avoided by applying an undercoat of another metal, such as copper, to serve as a moisture barrier. The difference in potential between nickel



or chromium and aluminum is so great, that precautions must be taken if both are used in equipment in which electronic conduction between them is possible.

The Precious Metals. The precious metals include gold, silver, and the so-called platinum metals, such as platinum, palladium, iridium, ruthenium, osmium, and rhodium.

The chief advantage of precious metals is that they do not readily oxidize or tarnish upon exposure to the atmosphere. Though silver contacts tarnish, the salts of silver are highly conductive. Silver plating is used on tuned elements and wave guides to reduce losses, although gold plating is preferred on those portions of wave-guide plumbing where corona or arcing may occur. Gold plating has shown no attack after being used for two years on radar equipment exposed to saline atmospheres. Much trouble has been experienced from silver migration when silver is in the presence of phenolics and moisture. Refer to the chapter on Component Parts, under the heading of "Capacitors," for data on this subject.

Dissimilar Metals. It is a well-known fact that threaded connections between metals widely separated in the galvanic series quickly deteriorate. The same type of corrosion can occur at riveted or bolted joints, bearings, and slides. Though there is considerable literature on the subject, including government specifications, it must be pointed out that the electromotive series should not be relied upon too strongly in deciding which combination of metals is to be used. The corrosion behavior can be changed markedly by such environmental factors as temperature, and by any one of the numerous possible surface reactions. The only way to obtain a correct estimate of probable corrosion is to conduct tests on the actual materials in the specific corrosive environment that is to be encountered.

## SAND AND DUST EFFECTS

In most locations, sand and dust do not play a very important part in the difficulties associated with the operation of electrical and electronic equipment. But, as pointed out by Greathouse and Wessel,<sup>2/</sup> it is possible that under dry, hot, desert conditions, and on desert islands that have been built on coral or that are the remnants of volcanoes, dust and sand may be present in amounts sufficiently great to interfere with proper operation of equipment and to cause failure. Large amounts of dust are carried by the air, especially during sand storms, and the dust particles seem to be able to penetrate almost any enclosure.

Serious damage is caused by dust because it can get between moving surfaces and bind moving parts. On the coral islands of the Pacific, the coral dust slips in between metallic contacts and provides insulation where it is not wanted. Among the difficulties encountered are arcing, sticking, and eventual burning out of contact points. Dust accumulates between high-tension electrodes in radar equipment

and also promotes arcing. It gets into connectors, causing them to stick, and making disconnection difficult. The abrasive action of dust and sand rapidly damages the armatures of motors and generators.

Some kinds of dust are hygroscopic, and their presence on metallic surfaces actuates the corrosion process. Volcanic dusts contain constituents that hasten the corrosion of iron surfaces in particular. Dust can even become embedded in some types of die-castings, and may be responsible for a phenomenon known as "growing." If movable parts are so affected, seizure eventually takes place.

Though the sand and dust problem is found primarily in tropical-desert regions, it is by no means restricted exclusively to these parts. Paine, reporting on the major failures in Whirlwind I for the period from August 1951 through May 1952,<sup>32/</sup> stated that arc-over between terminal lugs mounted on the phenolic panels of two WW I units had occurred to date. Apparently, dust from the air in the computer room acquired a static charge and tended to deposit about points of moderately high potential. Though the report does go on to state that this arc-over may have been brought about by an apparent deterioration of the phenolic material, it is felt that the report does highlight the topic under discussion. The problem of sand and dust is one more factor the engineer must consider as his design limits become more critical.

According to Hannahs,<sup>33/</sup> the endurance of radio receivers requires that consideration be given to the effects of humidity, temperature, and dust. This problem was highlighted by the introduction of portables having connective circuits printed on plastic decks. Figure 6-10 illustrates the combined effects of dust and moisture on a printed circuit, the insulation resistance between two parallel conductors being notably decreased, even though a coating of protective varnish has been applied to one sample.

Solutions to the Dust and Sand Problem. In general, protection can be supplied by "dustproof" boxes and cans, embedding in plastic, wax potting, dip coating, overvarnishing normal insulations, immersion in oil, and use of pressurized cases or high vacuum. The two techniques of hermetic sealing and encapsulation are discussed elsewhere in this chapter, and should the designer turn to either, he must consider the disadvantages, as well as the advantages, inherent in each. In this regard, enclosing cabinets for electronic equipment is usually not considered in a discussion of reliability. But it, should be remembered that if they are not dusttight, the performance of the equipment is likely to suffer. A swinging inner panel, a large flat surface to apply dust-sealing gaskets, a strong handle that closes the cabinet under great pressure against these gaskets, and a minimum of cracks and openings have been found to be definite improvements over previously designed cabinets.

## SHOCK AND VIBRATION

Electrical and electronic equipment built to withstand the severe requirements of military service

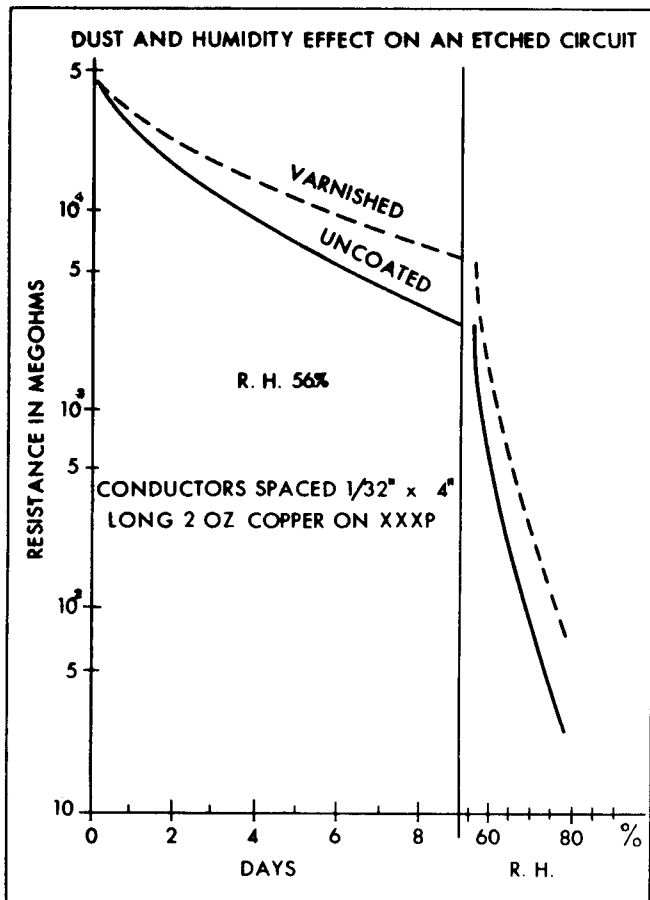

Figure 6-10. Dust and humidity effect on an etched circuit

must be engineered with much greater design or safety factors than those normally necessary for commercial equipment. The effect of vibration from powerful engines, and the shock resulting from firing of guns, near hits, depth charges, the obstructions encountered in travel, and so on, must be considered by the engineer when designing equipment for the Services.

**Definitions.** Shock occurs when a structure is subjected to a suddenly applied force. The first effect of shock is transient vibration of the structure at its natural frequencies. The vibration amplitude may become high enough to cause fracture of brittle material or yielding of ductile material. The second shock effect is that large accelerations, characteristic of the abrupt changes associated with shock, are transmitted to equipment and components supported by the structure.

Vibration is a continuing, periodic motion induced by an oscillating force. The force may be the result of mechanical movements, such as a reciprocating motion or a rotating unbalanced mass. Aboard ships, vibrations with frequencies no greater than 5 to 30 cps can be expected, /34/ while vibrations in aircraft can be expected to range from 0 to 10,000 cps, although the resonant frequencies of the

principal structural parts for larger planes occur from 0 to about 50 cps./35/

**Shock and Vibration Mounts.** There are three ways to support equipment that is subjected to forces transmitted through the mounting elements. These are (1) shock mounts (stiff mounts), (2) vibration mounts (soft mounts), and (3) solid fastening, without the use of any resilient mounts. Though shock mounts and vibration mounts comprise the two general classifications of resilient mounts, these two types are intended for different functions and are not directly interchangeable. They are quite similar in appearance and are seldom differentiated in the manufacturers' catalogs. In general, shock mounts use resilient material (such as rubber) in compression, whereas vibration mounts employ resilient material in shear. (See Figure 6-11.)

The principal difference between the two types is that shock mounts are designed or selected so that the natural frequency of the shock-mounted equipment is higher than any subjected vibration, and vibration mounts are selected so that the natural frequency is lower than the frequency of the disturbing vibration. Consequently, shock mounts do not protect equipment from vibration, and vibration mounts are ineffective against shock. The selection of the proper mount depends on the frequency and magnitude of the transmitted force and frequently requires a compromise that will best satisfy conflicting requirements.

Markowitz /36/ lists the three types of applications for which service requirements have been established.

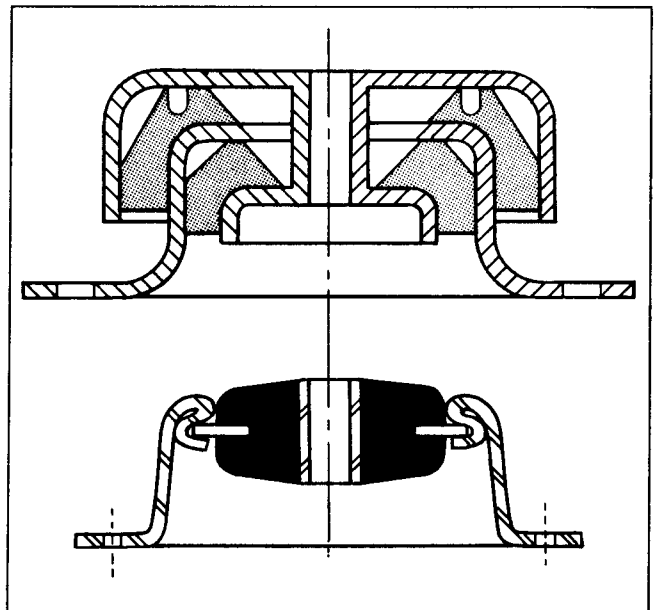

Figure 6-11. Cross-sectional views of shock and vibration mounts. (Courtesy of U. S. NEL, San Diego, California)

1. High-impact or ballistic shock, such as naval shipboard and submarine service.
2. Medium- to high-impact repetitive shocks, of which mobile applications are an example. (Either in vehicular installations or equipment installed in transit cases.)
3. Steady state vibration, such as is experienced in aircraft.

Failure in the first two cases is caused by high impact shock, and vibration is a secondary consideration. The equipment is subjected to a single transient shock wave, and failure is instantaneous. In the third case, fatigue failures of equipment and components are caused by steady state vibration at frequencies in the range of 10 to 500 cps. Here, the magnitude of the shock is much less than in the first two cases and is considered a secondary factor. Fatigue failures result from components being vibrated at or near their resonant frequency.

It is possible to obtain isolation from low frequencies, and also protection against high impact shock, but the space for such mountings is usually not available. At present, the maximum allowable height for shock or vibration mounts is about 1 1/2 in., which necessitates the selection of vibration isolators capable of isolating the lower frequencies or shock insulators that protect against high-impact shock. There is at present no mount of convenient size available that will attenuate both shock and vibration.

The isolation of frequencies as low as 10 cps requires a soft mount with a vertical resonance below 10 cycles. The isolation of high impact shock requires a stiff mount that resonates in the region of 25 to 33 cps. Therefore, vibration isolation and shock protection require two different types of mounts.

A typical arrangement of four resilient mounts is illustrated in Figure 6-12. This arrangement has six degrees of freedom with natural frequencies in translation and rotation about the X, Y, and Z axes. Should this arrangement be subjected to vibration, there are six possible frequencies that can cause trouble. In general, it is desirable to mount the equipment so that none of the natural frequencies coincide with any forcing frequency that may cause the system to vibrate at resonance. It is also desirable to keep the natural frequencies close together.

As an example, let an external forcing frequency be applied to the equipment. The curves in Figure 6-13 show the typical response to this action. For curve A, the equipment was mounted on soft vibration isolators with a natural frequency of 8 cps. The results of mounting the equipment on stiff shock isolators with a natural frequency of 25 cps is illustrated by curve B.

A study of Figure 6-13 reveals that mount A, with a natural frequency of 8 cps, begins to isolate at about 12 cycles; whereas mount B, with a natural frequency of 25 cps, commences to isolate at around

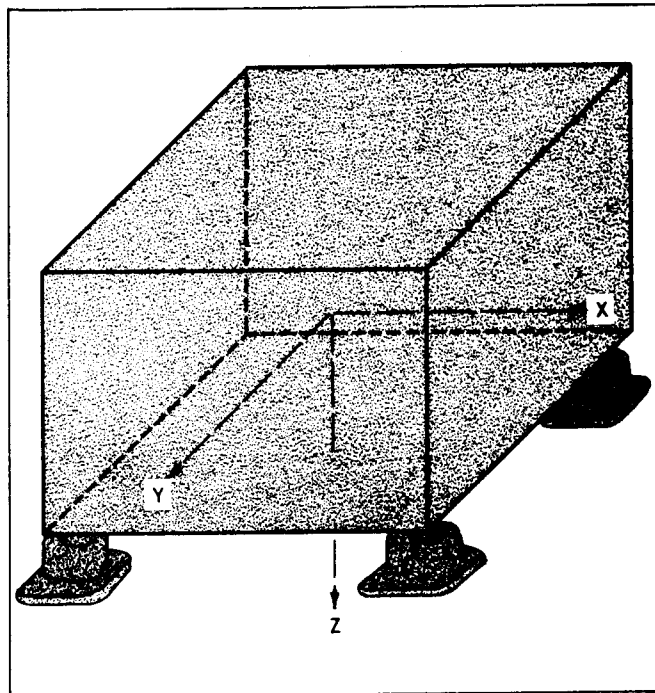

Figure 6-12. Representative piece of equipment supported on resilient mounts.

35 cps. Should the designer desire to isolate frequencies below 35 cps, a soft isolator of the A type would be required.

One way to visualize shock is to consider the support to which the equipment is attached suddenly to have acquired a high velocity. The mounted equipment then will move with the support at substantially the same velocity and displacement. With the insertion of a resilient shock mount between the support and the mounted equipment, a time delay is provided, which allows the equipment to acquire the maximum velocity, and the accelerations and forces on the mounted equipment are reduced. Energy is transferred through the isolator to the equipment, and the velocity of the equipment approaches the velocity of the support. The amount of energy that the mount transfers is dependent upon the weight of the equipment and the nature of the shock and is virtually independent of the characteristics of the isolator.

The load-deflection curves for the same mounts that were used in Figure 6-13 are shown in Figure 6-14. If the length R is the amount the isolator can deflect under a shock, the area under the force-deflection curve, up to the deflection R, represents the impact energy stored by the isolator. Static and dynamic properties differ, and the deflection of a mount under shock or impact will not give the same results as those obtained by a static load-deflection test. However, the results are similar enough to illustrate the point.

If a piece of equipment is mounted on isolator A, and then on B, and in each case is subjected to the same shock, then the weight of the equipment and

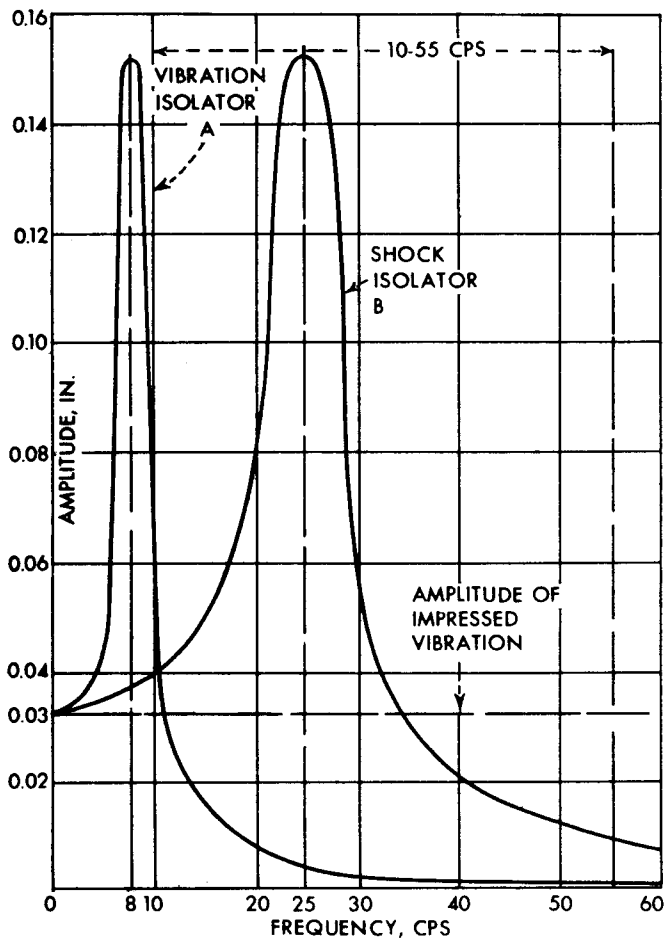

Figure 6-13. Response curves for vibration and shock isolators.

shock motion of the support in both instances is the same, and the area under curves A and B must be the same. This equivalent area means that the curve for isolator A must reach a greater peak force than the curve for isolator B. Greater shock is thus transmitted through mount A to the equipment, while the gradual increase of force for mount B makes it possible to attain the same area without reaching as great a maximum force.

Mount B has a higher initial stiffness than mount A, which accounts for its lower peak force, and though it can only isolate the relatively higher frequencies of vibration, it is these frequencies that accompany the shock.

In selecting mounts, it is usually possible to compromise on either one type or the other. For shipboard and mobile mounting, the damage caused by steady state vibration is of less consequence, and a mount should be selected to give primary protection against high shocks. A 25- to 30-cycle mount has frequently proved suitable for such applications. Airborne equipment, on the other hand, requires protection against fatigue failures caused by steady state vibration at frequencies in the 10 to 500 cps range. There is no need for protection against high

shock, since the aircraft itself is not capable of withstanding shock of such magnitude. In guided missile work, the major frequencies to be isolated are in the order of 40 to 1,000 cps. Because of the higher frequency range here, it is possible to select a shock mount that gives good shock protection and is also capable of isolating these higher frequencies. In all applications, however, tests should be performed to determine whether or not the selected mounts are suitable. These tests may range all the way from mounting the equipment on an anvil and striking the anvil with a hammer, to testing mobile equipment in the back of a truck.

**Results of Shock and Vibration Tests.** The Naval Research Laboratory has issued a report /37/ based on a study of 270 individual equipments, both electronic and nonelectronic, tested by NRL's Shock and Vibration Branch in accordance with prevailing Navy and military specifications. The equipment ranged in weight, from 3,025 lbs to less than 1 oz, and in size, from a radar antenna measuring 17 feet across the tips of the reflector, to small 30-ampere ferrule-type fuse clips. An attempt was made in the

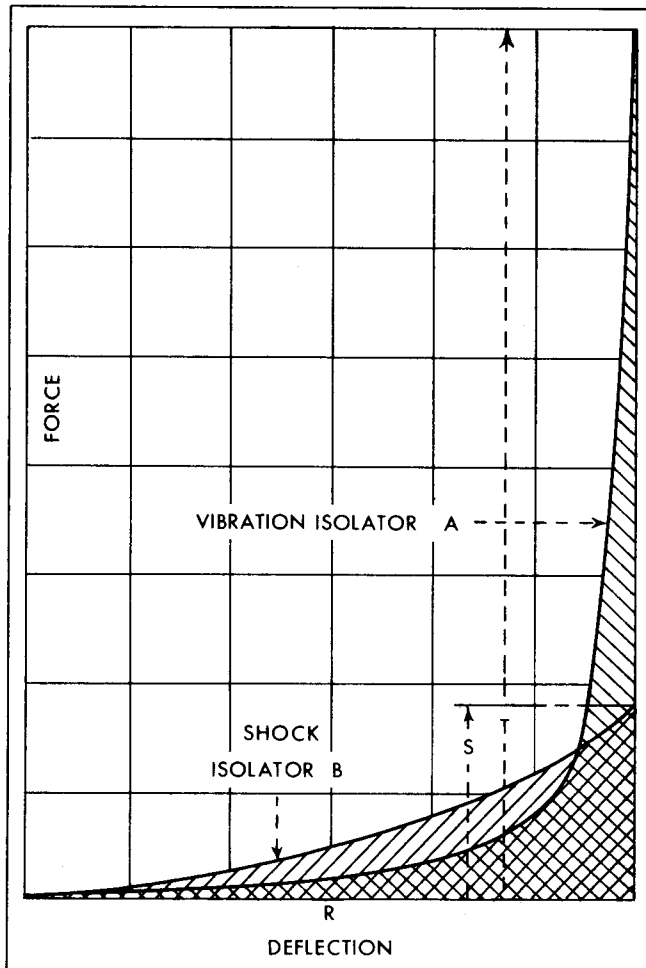

Figure 6-14. Load deflection curves for shock and vibration isolators. Area under curves represent stored impact energy.

report to show what is actually happening to the equipment, with emphasis placed on those areas most susceptible to damage. According to this report, approximately 90 percent of the damage to equipments resulting from shock and vibration can be eliminated in future designs using currently available component parts, provided those parts are chosen, modified (if necessary, in view of past test experiences), and mounted on structures that have good damage resistance.

Contrary to previous belief, it was found that vibration was as damaging to the equipments tested as was shock, even though the inertial forces acting on the units during vibration were low compared with shock — normally between 2 to 5 G's, as compared to 300. The reason was the repetitive nature of the vibration forces as compared to the short-duration shock blows. An equipment well designed for vibration was usually resistant to shock, but an equipment that passed shock tests might or might not have passed vibration tests. (There are opposite opinions held in this matter. Crede says that the reverse is true)./38/ In the Laboratory's investigations, vibrations tests were performed first.

Chassis, cabinets, and frame structures were found to be the principal areas of design that require more consideration by the equipment designer. Most of the difficulties resulted from a lack of sufficient structural stiffness. Poor structural design not only caused damage to itself, but was reflected in component part performance under both vibration and shock, and was perhaps the chief reason component parts failed.

The tests showed that critical parts should — and can — be arranged to benefit from the maximum deflections of the structure occurring during shock with very little increase in the damaging effect of vibration. The only component parts used in these tests that could be listed as critical were electron tubes and relays. Completely enclosed rotary-type relays and ruggedized electron tubes are possible — and promising — solutions to this problem.

Generally speaking, the problem of resistance to damage was demonstrated to be a mechanical one. In this connection, however, the tests provided strong evidence that just putting shock mounts on equipment is not enough to solve the shock and vibration problem. In the case of lightweight equipments, the NRL investigators found that many equipments could pass the required tests without shock mounts. Apparently, this was due to the fact that designers paid more attention to structural detail and component part installation in these equipments. Admittedly, there are cases in which shock mounts should be used; an example is mediumweight packaged electronic equipment, which requires shock mounts for the entire system. In any case, shock mounts are not desirable for vibration resistance because they function as vibration amplifiers.

Electronic Component Part Fasteners. The recommendations of one other report will be discussed here because the material covered is so applicable to

the subject at hand./39/ The purpose of this project was to establish guide rules for the proper selection of fasteners that withstand shock and vibration stresses as encountered under Service conditions in the assembly of electronic component parts.

Based on the results achieved during this program, several recommendations are made in regard to construction practices for obtaining greater dependability of electronic equipment in service.

Wiring. The use of long, unsupported lengths of solid wire as bus bars and so forth should be avoided. Such wiring is free to resonate. Where nothing interferes, large amplitudes are possible, with resulting high stresses. Flexible wires and cables should be tied down. Working of cabled leads can quickly result in failures of the wires at the terminals, as well as in chafing of insulation.

Lead-Mounted Component Parts. The most common type of failure encountered was that of lead-mounted component parts, such as resistors and capacitors. The practice of using terminal boards for such parts should be encouraged wherever practical. In addition, the use of a bonding agent, such as Dolph synthite, which does not become brittle, to bond the smaller component parts to the terminal board, is highly desirable. Above a certain weight, straps should be used. The U-type strap appears at this time to be the most satisfactory.

Brackets. Simple, unreinforced angle brackets on which the component part acts as a mass on a cantilevered beam are not generally satisfactory.

Screw-Type Fasteners. While this investigation has been little more than exploratory, there is indication that the size of screws currently used in the assembly of electronic equipment is adequate from a breakage standpoint. However, this should not be taken as a generally applicable rule until testing has been carried out on more component parts and on parts as redesigned with more rugged mounting details.

Failures caused by loosening have been shown in these tests to be sufficiently prevalent to require attention. There is indication from tests to date that consistent use of split lockwashers in place of the star types generally would improve the situation. However, lockwashers are not a cure-all, and the effect of this practice may be only to delay the failures.

There is substantial reason to believe that the factors that would effect the greatest improvement include control of tightening torque in assembly and use of holes correctly sized for the chosen screw to cut down motion where it may exist.

#### TRANSPORTATION AND STORAGE PROBLEMS

A piece of equipment, if it is to be of complete service to the user, should arrive at its destination in the same condition as when it left the assembly plant. This means that the designer of components,

as well as the designer of the equipment, must attempt to foresee and evaluate the various conditions that exist during transportation and storage.

A survey of some of the conditions that the equipment must survive may indicate the following requirements.

1. Transportation by truck or rail from the factory to a depot, military installation, or port of embarkation.
2. Transportation by ship to the port of debarkation.
3. Transportation of vital material by air and delivery by parachute drop in emergency situations.
4. Floating equipment ashore in amphibious operations.

Though these conditions in themselves are serious, the problem does not stop there. It must be remembered that, during transportation, the equipment will be handled by men primarily interested in expeditious moving. It may be dropped, used as seats, stood on, rolled, and wedged. Our present global military operations present widely varying environmental conditions, which also must be taken into account.

In an article by Dummer, /40/ it is stated that during the Pacific War, up to 60 percent of the equipment shipped to the Far East arrived damaged. Frequent and rough handling was responsible for some of this damage, but it was not the sole villain. It was not unusual to remove new equipments from their original packing, only to find the cases filled with water. Such a situation was due to the incomplete and haphazard waterproofing procedures followed in preparing materials for shipment.

Protection During Shipment and Storage. Preservation, packaging, packing, and marking are the four major steps taken in the preparation of material for shipment and storage. These steps are described /2/ as follows.

Preservation. Preservation is the process of treating the corrosible surfaces of a material with an unbroken film of oil, grease, or plastic to exclude moisture.

Packaging. Packaging provides physical protection and safeguards the preservative. Sealed packaging should be provided for all equipment, spare parts, and replacement units designed for shipment or storage. (See the section on "Hermetic Sealing.") Flexible waterproofing packaging, introduced during 1942, has also been found to provide high resistance to moisture penetration. A "water-vapor-proof barrier" is usually a bag of several layers to which a dehydrating agent is added. The outer layers provide strength; the inner layers consist of a metal foil "barrier" and a plastic coat. The plastic coat permits closure of the barrier by means of heat.

Such packaging has given good service; it is not unusual at the present time to open packages sealed during the war and find the silica-gel moisture indicator still blue in color. These barriers, however, have a measurable moisture transmission rate and do not offer permanent protection, unless the dehydrating agent is renewed at certain intervals. Since the war, much attention has been given to vapor-proof packaging, and substantial improvements have been made in this form of protection.

Packing. Packing is the process of using the proper exterior container to ensure safe transportation and storage. Standard commercial packing procedures are ordinarily used in the preparation of materials for domestic shipment. Preparation of material for overseas shipment requires adequate protection against unusually rough handling and severe atmospheric conditions. The metal foil barrier used in vaporproof packaging is broken or punctured rather easily, and utmost precaution should be taken in packing to protect the barrier from such an accident. A broken barrier is worse than none at all, since it allows water to accumulate in the container by the process of breathing. The Tropical Science Mission found that even with the better type of packaging, 10 percent of the packages arriving at a destination in the South Pacific were punctured or torn open. The units contained in these packages were subjected to greater deterioration than in any other type package.

Marking. Marking is identifying information that facilitates prompt delivery and ease of storage.

Storage. Whenever it is possible, material should be stored in dry, well-ventilated warehouses, where the temperature of the air surrounding the equipment can be regulated so that it does not fall to dew-point values at night. Storage in air-conditioned buildings is, of course, ideal. If equipment is stored in bins, it is important that it be placed above floor level. Large equipments may be stored in well-ventilated rooms without packaging, although equipments having a tendency to corrode should be protected with vaporproof coatings.

## INSTALLATION

When equipment arrives at its destination, installation is the next step and, as such, must also be considered as a part of the reliability problem. The location of the equipment may present the first difficulty. The situation may require a particular location of instruments, indicators, and control accessories, which in turn may demand connection leads of a length, or cause an electrical exposure, that the designer did not foresee, and for which no provision was made. Low signal levels, poor signal-to-noise ratios, and excessive control circuit resistance can be the cause for unreliable operation as the other operating facts combine in varying ways from day to day. According to Cook, /41/ the simple procedure of grounding circuits can often introduce problems that affect the accuracy, and even the life, of components. Examples can be cited from private industry in which heavy machine currents flowed through a delicate electronic equipment to its detriment, merely because the ground

on the electronic equipment had a lower resistance than that of the machine. Large power currents in the ground system of an electronic equipment can introduce electrical noise of an amount that would seriously alter the reliable performance otherwise available from the electronic equipment.

There are other problems arising from installation. The difficulties of vibration and electrical noise are assumed to have been eliminated by the designer before expensive foundations, structures, and other facilities are provided to receive the equipment. Should these difficulties remain unsolved, marginal utility and user dissatisfaction are likely to result. Ambient conditions must also be considered. It is possible that in a particular installation, the ambient temperature at certain periods will allow maximum hot-spot temperatures in component parts to

approach, and even exceed, their normal temperature limits. To design an equipment to meet average ambient conditions is one thing, but to be sure that the ambient condition never exceeds the limits set by reliable design is another. Continued periods of abnormal ambient conditions of temperature or moisture can be as detrimental to good performance as poor design. When this can be predicted in the early stages of design, a solution can be arrived at by using component parts at below their normal power ratings and by applying proper protection. Where the design cannot be changed to take care of what amounts to a special circumstance, individual solutions must be applied. No matter what the problem or the solution, installation plays its part in the reliability of electronic equipment. The more the electronics designer anticipates possible poor reliability resulting from bad installation practices, the better will his equipment serve its intended purpose.

## REFERENCES

1. Jackson, Willis, The Insulation of Electrical Equipment, p. 161 ff, John Wiley and Sons, Inc., New York, 1954.
2. Greathouse, Glenn A., and Carl J. Wessel, Deterioration of Materials, Causes and Preventive Techniques, Chapter 11, Reinhold Publishing Co., New York, 1954.
3. Steinberg, E. B., and F. J. Oliver, "Subminiature Electron Tubes Are Reliable," Electrical Manufacturing, Vol. 50, No. 3, September 1952.
4. Booth, R. Y., and J. P. Welsh, Survey Report of the State of the Art of Heat Transfer in Miniaturized Electronic Equipment, Report No. HF-710-D-10, prepared under Bureau of Ships Contract No. NObsr-49228 by Cornell Aeronautical Laboratory, Inc., March 3, 1952.
5. Robinson, Walter, and John R. Barton, "The Thermal Evaluation of Air-Cooled Electronic Equipment," AF Technical Report No. 6579, Supplement 1, prepared for Wright Air Development Center under Contract No. W33-038-ac-14987 with the Ohio State University Research Foundation, August 1953.
6. Lead-Acid Storage Batteries at Low Temperatures, Technical Memorandum No. M-1123, Signal Corps Engineering Laboratories, Fort Monmouth, N. J., 1 March 1948.
7. Signal Corps Tests, Fort Churchill, Canada, Winter 1951-1952, Technical Memorandum No. M-1461, Signal Corps Engineering Laboratories, Fort Monmouth, N. J., 18 September 1952 (Restricted).
8. Winter Tests, 1951-1952, Fort Churchill, Canada, Engineering Report No. E-1099, Procurement-Maintenance Engineering Division, Signal Corps Engineering Laboratories, Fort Monmouth, N. J. (Restricted)
9. Hunter, Dr. John, and M. G. Whillans, A Study of the Effect of Cold on Joint Temperature and Mobility, Canadian Medical Department.
10. Climatic Extremes for Military Equipment, Report No. 146, Environmental Protection Branch, Research and Development Division, Office of the Quartermaster General, November 1951 (Restricted).
11. Abbe, C., "Gigantic Snow Flakes," Monthly Weather Review, Vol. 52, pp 530-532, November 1924.
12. Jacobs, Yale, "Fundamentals of Electronic Equipment Miniaturization," AF Technical Report No. 6105, Wright-Patterson Air Force Base, Dayton, Ohio.
13. Alexy, M. R., "Design Considerations in Miniature High-Voltage Airborne Components," Electrical Manufacturing, Vol. 50, No. 11, May 1953.
14. Sulzer, P. G., "Circuit Techniques for Miniaturization," Electronics, August 1949.
15. Electronic Miniaturization, Final Report, National Bureau of Standards, Contract No. NAer 00685, September 1949.

## REFERENCES (Cont)

16. Coblenz, Abraham and Harry L. Owens, "Transistors – Theory and Application," Part I, Electronics, March 1953.
17. Mammola, J. P., "Electronically Regulated Transistor Power Supply," AFCRC Technical Report No. 53-12, Research Ships Division, Air Force Cambridge Research Center, Cambridge, Mass., April 1953.
18. Doyle, C., USAF, "Transistor Circuit Components," paper presented at National Conference on Airborne Electronics, Dayton, Ohio, May 10, 11, and 12, 1954.
19. Cuming, W. R., "Casting Resins for Electronic Equipment," Tele-Tech, Vol. 12, No. 3, March 1953.
20. Electronic Equipment Construction (New Objectives – New Techniques – New Components), Terminal Report, June 1, 1950, Contract No. N7Onr-32103, Stanford Research Institute, Stanford, Calif.
21. Field, Robert F., "Formation of Ionized Water Films on Dielectrics Under Conditions of High Humidity," Journal of Applied Physics, No. 17, pp. 318-325, 1946.
22. DeLerno, M. J., "Potential Breakdown of Small Gaps Under Simulated High-Altitude Conditions," Electrical Engineering, No. 63, pp. 109-112, 1944.
23. Report of Committee D-9 on Electrical Insulating Materials, Reprint No. 65, p. 17, American Society for Testing Materials (ASTM), Philadelphia, 1948.
24. Leonard, J. M., "Failure of Electronic Equipment Under Tropical Service Conditions," Report No. P-2475, Chemistry Division, U. S. Naval Research Laboratory, Washington, D. C., February 1945.
25. Leutritz, John Jr., and David B. Herrman, "The Effect of High Humidity and Fungi on the Insulation Resistance of Plastics," ASTM Bulletin, No. 138, pp. 25-32, 1946.
26. Witt, Ralph K., "Moisture and Fungus Deterioration of Electrical and Mechanical Properties of Plastic Materials," paper presented at the technical program of the Electrical and Electronic Subcommittee of the U. S. Deterioration Prevention Committee, Washington, D. C., April 1948.
27. Luce, R. H., and K. N. Mathes, "Moisture and Fungus Deterioration of Electrical Characteristics of Hook-up Wire," paper presented at the technical program of the Electrical and Electronic Subcommittee of the U. S. Deterioration Prevention Committee, Washington, D. C., April 1948.
28. Leonard, J. M., "Effects of Moisture and Mildew on Electronic Equipment," Electrical Manufacturing, Vol. 50, No. 3, September 1952.
29. Molnar, D. M., and J. M. Leonard, "Tropical Deterioration of Materials for Electronic Equipment," Part I, Report No. P-2492, Naval Research Laboratory, April 1945.
30. Report by Branch of the Master General of the Ordnance, Ottawa, Canada, on Design of Canadian Army Radar Equipment for Use in Tropical Theatres as Exemplified in Design of Radar A. A. No. 4, Mk. 6, under joint operation of Directorate of Armament Development, Canadian Department of National Defense, National Research Council of Canada, and Research Enterprises Ltd., March 31, 1945.
31. Tropical Deterioration of Air Force Materiel and Equipment, Tropical Science Mission, U. S. Air Force, May 1946.
32. Paine, B. B., Major Failures of Components in WW I, August 1951-May 1952, Digital Computer Laboratory, Massachusetts Institute of Technology, Cambridge, June 11, 1952.
33. Hannahs, W. H., "Protecting and Packaging Electronic Equipment," talk presented at the Spring Lecture Series, Long Island Section, IRE, 1954.
34. Cherrick, Irwin L., "Rugged Electron Tubes," Electronics, April 1948.
35. Willson, Abner R., "Vibration Testing of Airplanes," Electronics, March 1949.
36. Markowitz, J., "Shock or Vibration Insulators?," Product Engineering, June 1953.
37. Woodward, Kenneth E., "Damages Resulting from Laboratory Vibration and High-Impact Shock Tests," NRL Report No. 4179, Naval Research Laboratory, Washington, D. C., September 11, 1953.
38. Crede, C., Vibration and Shock Insulation, p. 316, John Wiley and Sons, Inc., New York, 1951.



## REFERENCES (Cont)

39. Investigation of Fasteners for Mounting Electronic Components, Final Report, prepared for the U. S. Army Signal Corps Engineering Laboratories, Fort Monmouth, N. J., under Contract No. DA-36-039, SC-5545 with the Calidyne Co., 1952.
40. Dummer, G. W. A., "The Engineering of Radar Equipments," Electronic Engineering, August 1952.
41. Cook, E. D., "Reliability in Industrial Electronic Equipment," paper presented at the AIEE Summer General Meeting, Atlantic City, N. J., June 1953.

## ANNOTATED HEAT BIBLIOGRAPHY

Bentley, Wilson A., "Forty Years Study of Snow Crystals," Monthly Weather Review, Vol. 43, p. 73, 1915.

Drake, D. T., "Heat Transfer in Aircraft Electronic Equipment," Report EM-226, prepared under Contracts No. W33-038-ac-14191 and AF33(038)-20921 with North American Aviation, Inc., March 31, 1952 (Restricted).

A discussion, which attempts to make reasonable approximations without involved calculations, of the various methods of heat transfer. Methods are given for calculating or estimating the heat conductance factor for a line of standard modular packages specifically designed for good heat transfer characteristics. Design features considered are short conduction paths, high emissivity surfaces, and heat shielding of low-temperature components.

Drake, D. T., "Heat Transfer in Subminiature Electronic Equipment," Tele-Tech, Vol. 12, No. 6, pp. 111-113, 154, June 1953.

An apparent digest of North American Aviation Report EM-226.

Electronic Equipment Construction (New Objectives — New Techniques — New Components), Terminal Report, prepared for the Office of Naval Research, under Contract N7Onr-32103, by the Stanford Research Institute, June 1, 1950.

An extensive survey of various techniques used to improve the construction of electronic equipment. The heat problem is discussed in general, and some of the techniques used to eliminate it are described.

Ericson, John R., "Airborne Equipment Cooling Problems," a talk presented at the Spring Lecture Series, Long Island Section, IRE, 1954.

A brief discussion of two approaches used in cooling airborne electronic equipment, that is, increasing natural cooling to a maximum and eliminating heat sources.

Klass, Philip, "New Shield Gets Rid of Tube Heat Fast," Aviation Week, December 14, 1953.

A brief discussion of the advantages of a new type of shield designed to dissipate tube-generated heat.

Kroko, Leonard J., "Vapor Cooling for High Altitudes," Electrical Manufacturing, Vol. 50, No. 4, pp. 120, 350, 352, October 1952.

This article describes how, at high speed operations in the stratosphere, it is possible to make use of the heat of vaporization of water to cool a 3-phase, 400-cycle, 12,000-rpm alternator.

Levy, Irving, "Shielding and Mounting Effects on Tube Bulb Temperatures," Tele-Tech, Vol. 12, No. 2, pp. 72-73, 159, 160, 163, February 1953.

This report is concerned primarily with the radiation effect of tube bulbs and with methods of improving heat conduction away from the bulb by means of various conducting shields and chassis mountings.

Robinson, Walter, "Heat Transfer from Electronic Components," Proceedings of Symposium, Progress in Quality Electronic Components, pp. 125-132, Washington, D. C., May 5-7, 1952.

A general discussion of the theory and some of the factors of heat transfer as applied to electronic equipment.

Robinson, W., L. S. Han, R. H. Essig, and C. F. Heddleson, "Heat Transfer and Pressure Drop Data For Circular Cylinders in Ducts and Various Arrangements," Report No. 41, prepared for Wright Air Development Center, under Contract No. W33-038ac-14987, by the Ohio State University Research Foundation, September 1951.

## ANNOTATED HEAT BIBLIOGRAPHY (cont)

This report discusses heat transfer and pressure drop relationships of cylinders in ducts with air flow normal to the axis for air velocities from 3 to 120 ft per second. Overall heat transfer coefficients and distributions of point heat transfer coefficients around cylinders are given for single, in-line, symmetrically staggered, and asymmetrically staggered arrangements.

Robinson, W., and C. D. Jones, "Cooling of Electronic Components by Various Methods," Report No. 44, prepared for Wright Air Development Center, under Contract No. W33-038ac-14987, by the Ohio State University Research Foundation, April 1952.

Cooling tests were performed in an effort to isolate basic modes of heat transfer. Tubes, transformers, relays, and resistors were studied for their thermal performance with free convection in air, mineral oil, silicone fluid, and Freon-113, with forced convection in air, under sprays of mineral oil and Freons, with radiation and gaseous conduction to cooled shields, and with direct conduction to cooled mounting surfaces. The experimental data on surface temperature distributions measured for these individual basic electronic components are presented.

Robinson, Walter, C. D. Jones, C. F. Sepsy, and E. V. Zaucha, "Forced-Air Crossflow Cooling of Electronic Units," Report No. 45, prepared for Wright Air Development Center, under Contract No. W33-038ac-14987, by the Ohio State University Research Foundation, February 1953.

This report presents the results of an investigation of forced-air cooling by crossflow over an electronic assembly that was designed by application of fundamental heat transfer data. The crossflow cooling method is evaluated for required design heat exchange effectiveness and cooling air power and its application in ram-air and blower-cooled systems.

Robinson, W., and R. H. Zimmerman, "Methods for the Ultimate Dissipation of Heat Originating with Airborne Electronic Equipment, AF Technical Report No. 6493, prepared for Wright Air Development Center, under Contract No. W33-038ac-14987, by the Ohio State University Research Foundation, March 1951.

A discussion of the methods and systems that may be used for the ultimate dissipation of heat originating from electronic equipment. The seven systems principally considered are: (1) air-cooling by use of blowers, (2) ram-air cooling, (3) expanded ram-air cooling, (4) air-cooling by flush skin heat exchangers, (5) heat dissipation to fuel, (6) heat dissipation to expendable evaporative coolants, and (7) heat dissipation by radiation to space.

Robinson, Walter, and R. H. Zimmerman: "The Thermal Evaluation of Air-Cooled Electronic Equipment," AF Technical Report No. 6579, prepared for Wright Air Development Center, under Contract No. W33-038ac-14987, by the Ohio State University Foundation, September 1952.

This report classifies, according to their cooling methods, the various air-cooled electronic equipments designed for airborne application. Basic thermal test methods and techniques of making the necessary measurements are described, with emphasis on bench testing. One chapter is devoted to the theory, performance, evaluation, and selection of cooling blowers.

Selgin, P. J., and B. K. Hawes, "Temperature Prediction in Electronic Design," Electrical Manufacturing, Vol. 50, No. 4, pp. 116-119, 376, 378, October 1952.

Knowing the power dissipation, and using the charts presented in this article, a designer may relate temperature to heat loss by radiation and convection in prism- and cylinder-shaped parts, such as are encountered in electronic assemblies. Simplified procedures are described whereby it is possible to predict, with a minimum of computation, the temperature of a body whose heated inner core is at a higher temperature than the surface.

Sissenwine, N., and A. Court, "Climatic Extremes for Military Equipment," Report No. 146, Environmental Protection Branch, Research and Development Division, Office of the Quartermaster General, November 1951 (Restricted).

Environmental conditions whose extremes may damage military equipment, or render it inoperative, are defined under seven stresses: thermal, humidity, precipitation, wind, penetration and abrasion, salt spray, and atmospheric pressure. Conditions are proposed for the design and evaluation of military equipment intended for use under such extremes.

Welsh, James P., "Recommended Temperature Measuring Techniques and Ratings for Electronic Parts," Proceedings of the 1953 Electronic Components Symposium, pp. 9-1 to 9-6, Pasadena, Calif., April 29, 30, May 1, 1953.

This article suggests various ways for measuring temperature and describes the application, advantages, and limitations of the various methods.

## ANNOTATED ENCAPSULATION BIBLIOGRAPHY

Dummer, G. W. A., and D. L. Johnston, "New Constructional Techniques," Electronic Engineering, Vol. 25, No. 309, pp. 456-461, November 1953.

A brief discussion of the techniques used in encapsulating.

Greathouse, Glenn A., and Carl J. Wessel: "Deterioration of Materials, Causes and Preventive Techniques," Chapter 11, Reinhold Publishing Corp., New York, 1954.

An excellent review of the environmental factors that affect reliability. Various plastics are discussed and the characteristics of each described. The advantages and disadvantages of hermetic sealing are discussed with regard to the overall reliability of electronic equipment.

Jacobs, Yale, "Fundamentals of Electronic Equipment Miniaturization," AF Technical Report No. 6105, Wright-Patterson Air Force Base, Dayton, Ohio, January 1951.

A general discussion of casting and the part it plays as an assembly technique in aiding the miniaturization of electronic systems.

"Resin Embedment of Electronic Circuitry: A Study of Practical Techniques," Report 318, Evaluation Branch, Engineering Services Division, U. S. Navy Electronics Laboratory, San Diego, Calif., July 1952.

A good general description of the procedure followed in the embedment process. Though most of the material presented applies specifically to NEL Casting Resin 177, there is also a wealth of general information in this report.

## ANNOTATED HERMETIC SEALING BIBLIOGRAPHY

Greathouse, Glenn A., and Carl J. Wessel, "Deterioration of Materials, Causes and Preventive Techniques," Chapter 11.

See under "Encapsulation."

## ANNOTATED MOISTURE BIBLIOGRAPHY

Csepely, J. A., and G. K. Borski, "Appraisal of Relay Design," Proceedings of Symposium on Electro-Magnetic Relays, pp. 11-19, Oklahoma A&M College, Stillwater, Oklahoma, June 29-30, 1953.

A discussion of how to determine the good and bad design features of electromagnetic relays by visual and mechanical means. The action of electrolytic corrosion on relay windings is discussed, along with the various methods of reducing this hazard.

## ANNOTATED SHOCK AND VIBRATION BIBLIOGRAPHY

Crede, Charles E., "How to Evaluate Shock Tests," Machine Design, December 1951.

Shock tests are often applied to investigate the ability of equipment to withstand the rough handling received in transit and during military service. To be able to specify and evaluate these tests, it is first necessary to understand the fundamentals of the response of a mechanical structure to shock conditions. This article discusses basic considerations in this respect.

Crede, Charles E., and Miguel C. Junger, "Designing for Shock Resistance," Machine Design, December 1950-January 1951.

A general discussion of the principles that relate to shock resistance of structures.

Dickie, R. J., "How to Apply Vibration Isolators," Electronics, December 1952.

Improperly-applied vibration isolators may amplify, rather than reduce, mechanical motion imparted to electronic equipment aboard aircraft, ships, and other vehicles. This article provides a guide for use of isolators to minimize vibration-caused malfunctions.

**ANNOTATED SHOCK AND VIBRATION BIBLIOGRAPHY (cont)**

Vibration and Shock Design Criteria for Electronic Equipment, Interim Engineering Reports, prepared under Contract No. AF 33(038)-22704 with the Barry Corporation, Watertown, Mass., 1953-1954.

This report discusses a method for analyzing service shock conditions and presenting the data in a form that permits direct comparison with steady-state vibration conditions.

Wood, Ross, "Reliability of Filamentary Subminiature Tubes," Tele-Tech, March 1953.

The rugged construction of filamentary subminiature tubes has resulted in their giving long periods of satisfactory operation. This article describes how these tubes are designed to withstand extreme shock and vibration conditions.

# CONTENTS

chapter seven

## **human engineering**

Vision

Audition

Skin Sensitivity and Proprioception

Motor Performance

Body Measurement

Application of Human Engineering Principles

# chapter 7

## HUMAN ENGINEERING

Man, a discontented animal, has made constant and unremitting efforts through the ages to amplify and extend his own rather frail powers. The cave dweller threw rocks; later generations invented the catapult, the cannon, and the long-range gun with its fire-control system; the scout and the lookout gave way to the patrol plane and the search radar. Particularly, in this century, the progress of science and technology has been fantastic, with the result that machines play an increasingly larger part in peace and war.

But the elimination of certain difficulties caused by human limitations has more often than not resulted in new ones being created. The price of man's success in building machines to increase the power of his arms, ears, and eyes is, almost invariably, increased complexity in the machines.

Until recently, this difficulty was of minor importance. Man found he could keep pace with technological complexity by carefully selecting and training the men to operate the equipment. "Fitting the man to the machine," it was called, and it worked as long as the machine remained relatively simple.

Changing Technology. But this happy solution was not destined to remain static. The man-made machine is capable of constant change — in increasing scope, power, and speed of operation — and to perform its miracles, it grows ever more intricate. For example, there were 60 electron tubes aboard a destroyer in 1937, 850 in 1944, and 3,200 in 1952. A mobile search radar for ground defense contains more than 500 tubes, 2,000 resistors, 1,500 capacitors, 300 transformers, and 10,000 parts. The pilot of the '20's flew by the "seat of his pants," with a little help from the airspeed indicator, tachometer, and needle and ball. Today, his counterpart is faced with an array of 200 or more switches, controls, and indicators.

Man himself has not taken on new dimensions — nor can he be expected to change appreciably in the

foreseeable future. His capabilities must be considered constant, in contrast to the apparently limitless progress of the equipment he builds. Thus, he has fashioned, technologically speaking, a Frankensteinian monster whose complexity threatens to dwarf its creator. The machines multiply his effort and power but, with fine impartiality (they take no account of human limitations), also multiply his mistakes. Bristling with dials and switches, the machines stand ready to make the magic, but much of their effectiveness is lost because the operators can't control them properly. This was graphically demonstrated during World War II, when so much of our mechanically and mathematically accurate equipment — particularly electronic equipment — stood idle or performed at less than maximum capacity because of the limitations of the operators.

Fitting the man to the machine remains an important concept, of course, as varying mental and physical capabilities render some people better than others for certain jobs. But it provides at best only a partial answer. Some machines have reached a level of intricacy where even competent and well-trained individuals can't cope with them. Further, most machines must be manned by average people, and the operation is conditioned by the man's capabilities under conditions of fear, fatigue, stress, and sudden and unexpected change.

A qualification is necessary here. The difficulty is not always that the human being is simply overwhelmed by a mass of gadgets. Job complexity can have an impact on performance long before the machine gets very intricate. The equipment a person uses does not have to be especially complicated to hamper his performance. Three dials, if badly designed, arranged, or illuminated, may be difficult to watch than fifteen good ones.

Why Operators Fail. World War II spelled out as never before the familiar axiom that a military weapon is only as good as its human operator.

Machines and equipment performed at maximum capacity only if the operator did what he was supposed to do, in the proper sequence and at the proper time.

There were a variety of reasons the operators failed to do their jobs. They made mistakes because they were often hastily or inadequately trained, because of fear and fatigue, and because of sheer incompetence, which is a result of inadequate selection. But they also failed because the intricate engines of power, communications, and transportation were designed without sufficient attention to the capacity — both mental and physical — of the men who had to run them. The machines imposed demands that overtaxed the facilities of perception, action, reaction, and decision of the operators.

The Beginnings of Human Engineering. There was an obvious need for systematically observed information on the human factors. Psychologists were called in to make critical investigations of the average human being. For example, physical limitations were studied in the field of aviation, and psychological studies of behavior were made in combat information centers. This was the real beginning of the as yet inexact science of human engineering, with the goal of providing designers with the probable characteristics of the average individuals who will man tomorrow's machines.

Involving aspects of psychology, physiology, physics, biology, anthropology, medicine, and even spiritual values, human engineering might more correctly be called engineering psychology, since it requires close alliance between engineer and psychologist — or psychological understanding on the part of the engineer.

Many industrial and government organizations are doing research in this fascinating field. An excellent guide to practical applications of principles that have evolved from many of these studies has been published by the Naval Electronics Laboratory./1/ It has been very useful in preparing the material for this chapter.

What Is Human Engineering? Human engineers consider a complex military equipment as a man-machine system and see their task as one of increasing its effectiveness by treating it as a unified system. From this viewpoint, the human operator becomes an integral part of radar and sonar systems, communications networks, and so on. Because the performance of the system is determined by both components, the system will be improved if the mechanical component is designed to make the fullest use of the capabilities of the human being, to compensate for his limitations, and to give added scope to his unique evaluating and decision-making abilities by relieving him of purely mechanical tasks. In no way does this mean underestimating the ability of the operator; it does mean including as a design consideration an understanding of what he can and cannot do in certain circumstances.

The original approach of the human engineer was to start by improving the individual components

of a system. He could concentrate, for example, on making a dial more readable, a switch more accessible, or a seat more comfortable.

As man-machine systems became more intricate, the engineer changed his approach. He now tries to analyze and measure performance throughout the entire system by operating a priori — beginning with the general, overall difficulty and ending with the particular components. The information tells him both the need and value of improvements at various spots in the system. It is not unusual in making such an analysis to discover that saving several seconds by simple changes involving little cost can improve system performance, while other changes may cost a lot and contribute very little to overall performance.

It is well to keep in mind that the goal of a man-machine system is not speed, accuracy, quality of performance, safety, or comfort. These are certainly desirable, and help determine the efficiency of the system, but the real goal is to accomplish a specific task — to transport, produce, communicate, or destroy.

Human Engineering Terminology. Human engineering has, inevitably, produced its own specialized vocabulary. This terminology usually will be introduced where it is needed throughout this chapter, but some definitions are general enough to be discussed here.

Stimulus is any energy change in environment (a flash of light, a sound, a touch) that excites a receiving sense organ, such as the eyes, ears, or skin.

Response is a reaction to a stimulus.

Stimulus Threshold is the point dividing the energy level that can activate the sense organ from the level that can't.

Differential Threshold is the just noticeable difference between two stimuli.

In the human being, three sets of functions are important to the man-machine system response. These are receptors — senses, chiefly visual and auditory; central nervous system — the brain and spinal cord; and effectors — muscles, chiefly in arms and legs.

While human behavior is extraordinarily complex, and is affected by a large number of variables, certain characteristics are quite consistent. Human engineers accept as a fact that the human organism has the capacity (1) to perceive stimuli in the surrounding environment, (2) to sense differences and similarities between stimuli, and (3) to evaluate the size of these differences.

Also, the basic principle that man acts best in the man-machine system if he behaves as nothing more than a simple "amplifier" has been fairly well established. Such behavior ensures the best operating performance, because it achieves what the psychologists call stimulus-response integrity, a one-to-one ratio between stimulus and response. The operator

always knows that he is supposed to make the same response to the same stimulus, to manipulate the controls in the same manner in response to the same display conditions. Tests indicate that he must also have immediate evidence that his response has had the desired effect. If a proposed system is so complex that it will not permit the operator to function as an amplifier, perhaps a mechanical or electronic device should be substituted for the operator. Computers, for example, are sometimes used for this reason.

Confronted with human-engineering problems relating to a piece of equipment, the engineer or designer may not always have available the services of a human engineer. Even where such help is at hand, the liaison does not always result in a meeting of the minds, one reason for this being that the technical terms — the specialized jargon — often tend to impose a barrier to understanding. Working alone, faced with acting as his own psychologist, the engineer may find himself unable to keep up with the new data that is constantly being accumulated on the subject.

The designer who must provide his own psychological conclusions fortunately does not always face as formidable a problem as he may think. For one thing, designers have always included a certain degree of human-engineering considerations in their work, if only in crude form. (No one would design a hand-powered lawn mower, for example, so heavy and cumbersome that a man couldn't push or maneuver it.)

Again, once problems are recognized as such, they may be simple to solve. As in philosophy, the difficult job quite often consists in posing the right question. Once seen and defined precisely, the question may be solved with little difficulty.

Therefore, this chapter, in introducing the engineer and designer to the broad field of human engineering, is intended to serve a dual purpose: to supply data and information on the practical limits of human performance and sensitivity, beyond which the operator of machines begins to break down; and to compile the recommended practices in designing and adapting equipment to fit the human control equipment. The machines of the future must be designed with these criteria in mind.

Procedure for Handling Human Engineering Problems. As previously mentioned, stating the problem may be the most difficult and essential part of the job. In a study made by the Naval Research Laboratory, the primary human engineering questions were considered to be the following.

1. What are the information requirements? This involves an analysis of the proposed man-machine system in relation to the job it is supposed to do.
2. How can this job best be divided between man and machine?

3. When a man is needed, what are his capabilities and limitations — both mental and physical?

More specifically, the engineer must reach his design decisions with certain questions answered. Here are a few of them.

1. How difficult to operate and maintain is the equipment?
2. Who will perform these duties? On what basis will the operators be selected? How long will it take to train them?
3. How many people will use the equipment, and for how long?
4. Through what sense organ does the operator receive his information? (Does he go into action at the sound of a bell, a flash of light, or the like?)
5. What sort of discriminations does he have to make in these perceptions? (Must he distinguish between two lights of different colors, two tones of different pitches, or two numbers from different dial readings?)
6. What sort of response must he make? (Pull a switch, turn a wheel, or step on a pedal?)
7. As the design now stands, will it interfere with his ability to continue receiving the information he needs?
8. How should the controls and indicators be designed and arranged? What limits do body measurements impose on their location and arrangement?
9. How can communications facilities best be integrated into the work area?
10. What kinds of illumination are needed?
11. How critical are speed of operation and accuracy of readings?
12. What psychological and environmental conditions are encountered during the operation of the machine?
13. Have the job operations been simplified to present to the operator the fewest possible motions, the natural sequence of motions, and only the pertinent information, in order to minimize the chance of failure under stress?

When the designer has answered these and other questions, he can refer to the data in this chapter to find what factors make for optimum performance on the part of the operator. He can then check this information against preliminary design for the equipment. The next step usually consists of testing a



mock-up, using as many subjects as possible, under conditions approximating those found in the field.

## VISION

This section is intended to provide engineers and designers with a brief account of some of the characteristics and efficiency factors of the visual system — data on which many design decisions will be made.

Concepts and Definitions. Vision is the sense whose receptor organ is the eye and whose stimulus is electromagnetic radiations of certain wavelengths or, as we call them, visible light. Impressions transmitted through the light-sensitive part of the eye are carried to the visual centers of the brain for integration, evaluation, and interpretation. This visual process, by which we receive perhaps 80 percent of our knowledge, enables us to distinguish form, motion, color, and brightness.

When we look directly at a point, the entire area seen by the eye is called the visual field. The region immediately surrounding the point is the region of central vision, with an angle of about 3 degrees. Peripheral vision extends to the limits of the visual field; it covers about 140 to 160 degrees for each eye on the horizontal (Figure 7-1), and its vertical dimension is about 50 degrees above, and 80 degrees below, the horizontal.

Light reaching the eye is picked up by the retina, which is similar in function to the photographic plate of a camera. The retina is composed of two sets of light-sensitive cells, the rods and the cones. Cones, in the center of the retina, are highly sensitive to color and form and are generally associated with daylight vision. Rods, on the outer area of the retina, are sensitive to light and can only see black and white. They are mainly responsible for vision at night (when the illumination is less than full moonlight).

Convergence, the act of aiming both eyes at the same point, is also called fixating, and is accomplished by the eye muscles and the lens. The average time required to aim the eyes and focus them on a new point in distance is about 167 milliseconds.

The coordinated movement of both eyes without change of convergence is called the saccadic eye movement. The movement over a space of 5 letters of ordinary print, at a reading distance of 1 foot, takes 15 to 20 milliseconds. A movement of 20 degrees corresponds to about 4 inches on a page 1 foot from the eyes.

Extent of movement (degrees)	Duration of movement (milliseconds)
10	40
20	55
30	80
40	100

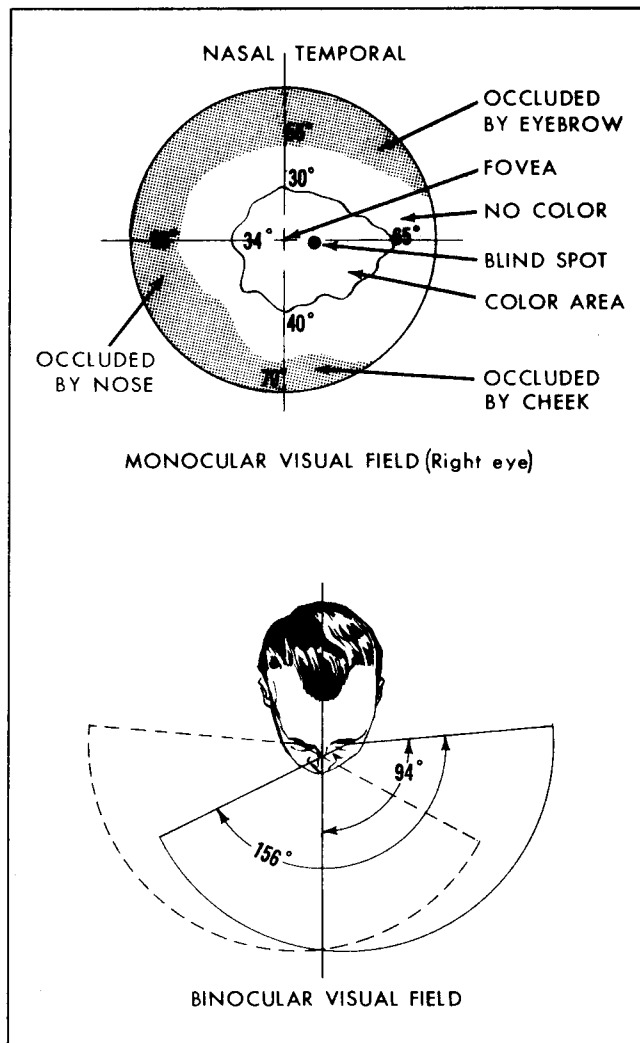

Figure 7-1. Monocular and binocular visual fields

## BASIC CHARACTERISTICS OF VISION

Light Sensitivity. The sensitivity of the eye to light depends, at any particular moment, on the time the eye has been exposed to a given level of illumination, as well as on such factors as the age and physical condition of the person, the characteristics of his eyes, the character of the stimulus (duration, intensity, and color of previous lights, and the size and type of object seen).

The most common manifestation of light sensitivity is adaptation, the process by which the eyes become accustomed to changes in the level of illumination. The increase in the eye's sensitivity to light as a result of time spent in the dark is called dark adaptation. The reverse of this — the decrease in sensitivity as a result of time spent in the light — is known as light adaptation.

Immediately upon entering darkness, the eye is not completely insensitive to light. Coming from light to dark, a person can see a dim light (about

0.03 millilamberts, the unit of brightness commonly used in experimental work). After 30 minutes, the sensitivity of the eyes increases about 15,000 times, and they are essentially at their maximum sensitivity to light. Light adaptation is much faster, requiring only about 6 to 8 minutes.

Goggles can be used to decrease the time required for dark adaptation. Red goggles or red illumination are useful if the operator needs some light for his activities just before exposure to night-vision conditions; but if he must adapt in the shortest possible time, total darkness is more effective.

**Brightness Discrimination.** The ability of the eye to detect differences in the brightness of objects is called contrast discrimination. The minimum intensity of light that can be seen is called the "absolute threshold" of vision. The visibility of point light sources in clear air at a distance of approximately 6 miles is as follows:

0.11 candle	visible in complete darkness
0.85 candle	visible in starlight
5.00 candles	visible in moonlight
85.00 candles	visible in twilight
8,500.00 candles	visible in daylight

As the data above show, a point of light source may be of low brightness against a dark background and still be seen clearly. Against a bright background, a light source must have a much higher intensity. Also, the larger the area of a light stimulus, the lower the threshold.

To be seen, a short flash of light must have a greater intensity than a longer flash. Isolated flashes that are of less than one-tenth second in duration,

however, are equally visible, if they contain equal energy.

The least discriminable difference between two intensities is called the "difference threshold." It increases with longer wavelengths of light and decreases as the intensity increases.

**Acuity.** Another function of the eye is to perceive the shape of objects and to distinguish fine detail. Acuity is usually measured by determining the size of the object that can just be discriminated at 20 feet. It varies greatly, depending on the object and its distance from the observer, the spectral distribution of radiant energy, the luminosity of the background, the contrast between object and background, the duration of the visual stimulus, and the criterion used to determine whether the object is or is not seen.

**Depth Perception.** When we look at an object, a slightly different view of it is seen by each eye. The slight difference in view permits what is known as depth perception, and enables us (with the help of visual cues gained through experience) to judge depth visually.

**Color Perception.** Not all the zones of the retina are equally sensitive to color. Some are recognized at greater angles from the center of the retina than others. Figure 7-2 shows the approximate limits of normal color differentiation.

Few people are actually color blind, but 3 to 6 percent of the male population are color deficient. That is, their range is restricted to two basic groups, yellows and blues, and while they never confuse these two groups, they find it difficult to distinguish between colors in the same group.

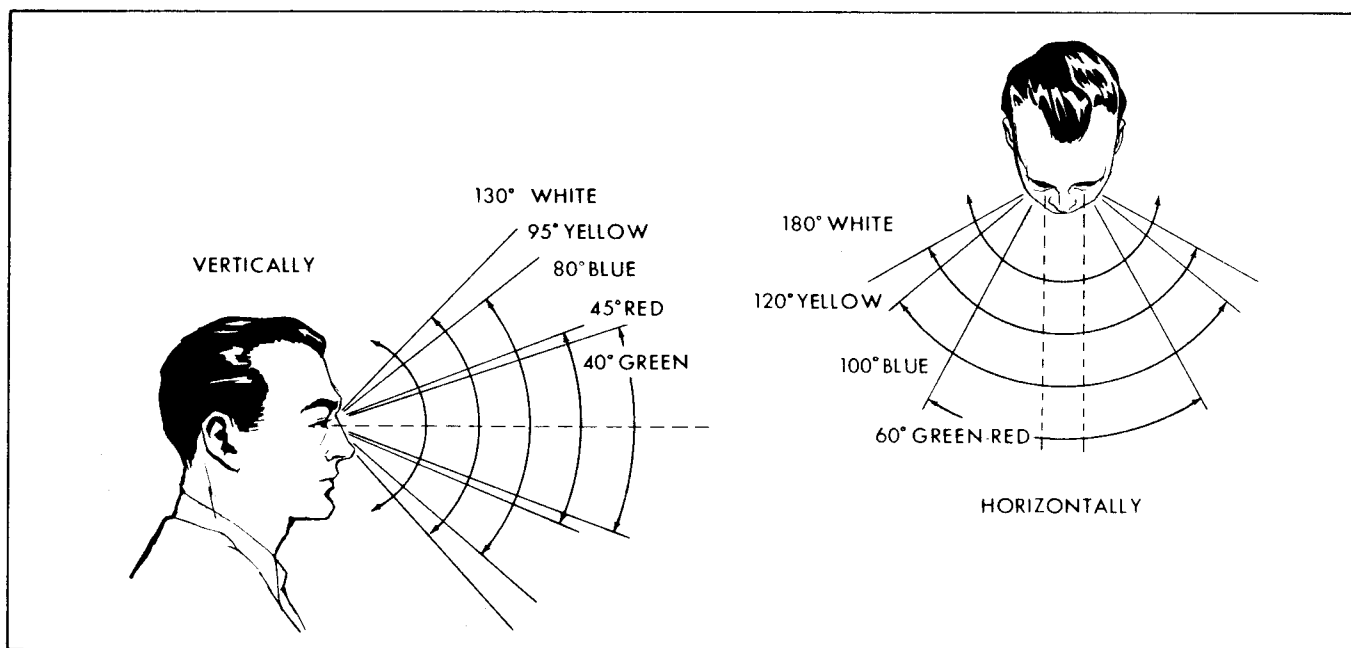

Figure 7-2. Approximate limits of normal color differentiation

Certain people have normal brightness sensitivity, but require an abnormal proportion of red and green to match a given yellow. Some have abnormal brightness sensitivity to the red end of the spectrum. Some confuse a particular shade of blue-green with gray, while a few rare people see only shades of gray.

**Movement Perception.** The eye's awareness of a continuous change in the position of an object is called perception of movement. In addition to objective movement, where the object actually does change its position, there is subjective, or apparent, movement. For instance, when lights are flashed in succession at the proper time interval, intensity, and distance from each other, the eyes get the impression of movement from one light to the other. If the second flash is more intense than the first, a backwards motion from the second to the first may be seen. Again, with alternate presentation of certain shapes in appropriate positions, the object may appear to move through three dimensions. These effects, known as "phi-phenomena," are used in motion pictures.

Other illusory movements are caused by the apparent motion of a stationary object when other visual references are lacking, by inaccurate perception of the relative movements of a stationary to a moving object when no visible references are present, and by distortion of a moving object. Afterimages are illusions occurring when the visual activity continues after stimulation of the retina has ceased. The afterimage movement is in the opposite direction. In positive afterimages, the black areas appear as black and the white as white; in negative afterimages, the colors will be reversed. With other colors, negative afterimages will produce colors that are complementary to those of the actual picture.

#### FACTORS INFLUENCING THE CHARACTERISTICS OF VISION

**Illumination.** Although visibility generally increases as the illumination increases, enough light does not necessarily guarantee adequate light. Improper illumination can reduce accuracy, cause accidents, induce irritability and fatigue, and slow down performance.

Daylight is considered the best light, artificial white light the next best. Colored light tends to tire the eyes. In reading, the eye fatigues least under amber light, then red, blue, and green.

Glare is the most harmful effect of illumination; it can increase muscular tension as much as 30 percent. Glare becomes less significant as the brightness of the object is increased, and is more easily controlled under high levels of illumination. This is treated in another section of this chapter.

**Atmosphere.** The contrast between an object and its background affects our ability to see that object. As a result, the surrounding atmosphere plays an important part in outdoor visual work, since the atmosphere tends to reduce the contrast by the two processes of absorption and scattering of light rays.

**Psychology of Color.** Color is a psychological experience, the perceptual response of the human being to the electromagnetic energy we see as light. In consequence, the influence of color on the emotions, and thus on performance, is powerful.

Because they vary in wavelength, colors vary in impact and force. For example, under red light, a person's pulse rate and blood pressure increase, and time seems to pass slowly. Blue light produces the opposite effect.

Red, orange, and yellow are thought of as warm tones, and blue, green, and violet as cool tones. However, color scientists have found that the warm end of the spectrum can have a bluish (cold) cast and the cool end a yellowish (warm) cast. In short, any known color may be either warm or cool.

With this in mind, the designer can use warm tones to excite, cool tones to give a feeling of calm. Also, a harmonious combination of colors (all hues either warm or cool) in an area can promote efficiency, while a discordant color scheme (mixed warm and cool) is conducive to restlessness.

#### AUDITION

In terms of providing information, hearing is our second most important sense. The elements necessary for hearing are the ear and its associated neural patterns, the sound source (a vibrating body), and the medium through which the vibrations are transmitted.

In this chapter, sound refers to the physical aspects — frequency, intensity (the sound pressure level), and duration. The intensity limits extend from the minimum level at which a sound can be heard, to

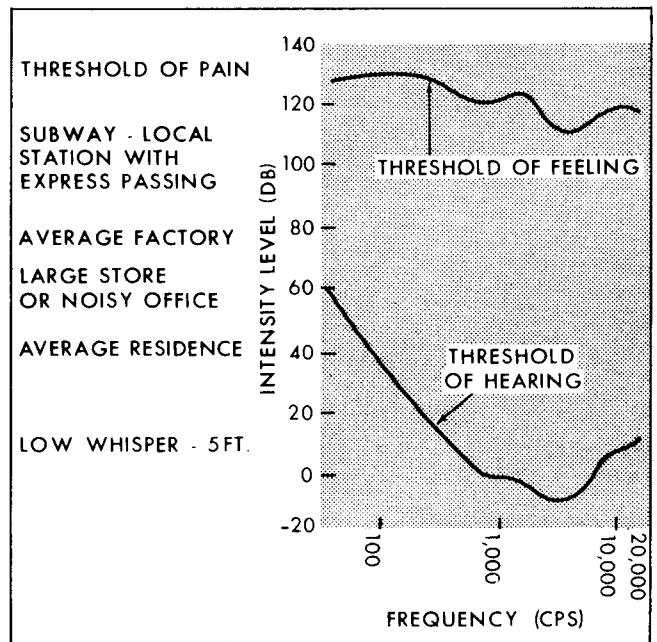

Figure 7-3. Effects of sound intensities at various frequencies

intensities at which feeling and discomfort begin (see Figure 7-3). Hearing refers to the subjective aspects — pitch, loudness, and duration, which are the responses of the auditory system to sound.

The sensation of highness or lowness of a sound is called pitch. It varies unevenly along the frequency scale and may vary in relation to intensity and duration. Most sounds have pitch.

Loudness is the hearing response most closely related to intensity. The sensation level — the magnitude of a sound above the threshold — is measured in decibels above the intensity of the just audible sound.

Detectability of loudness depends mainly on intensity, but frequency and duration also contribute to loudness changes. At sensation levels of 20 db or less, the intensity increase that is just noticeable as a loudness change is comparatively large — about 2 to 6 db, depending on the frequency. Above 20 db, an intensity increase of approximately 1/2 to 1 db is detectable, except at the frequency extremes, where the increase is somewhat larger. Within the frequency limits of about 500 to 10,000 cps, just noticeable differences of intensity are smallest.

As sound reaches a level of about 120 db, it becomes uncomfortable to hear; at 130 it begins to produce a feeling sensation; at 140 it becomes painful.

The human ear is limited in its ability to respond to sound, just as the eye is limited in its response to the light spectrum. Frequencies near the upper and lower limits require great intensities before they reach the threshold, and so are not generally heard. The normal human auditory range is generally considered to fall between frequencies of 20 to 20,000 cps, although these limitations vary somewhat with intensity. An individual's threshold may change from time to time, and declines in its response to high frequencies as the individual grows older.

The duration of a sound (measured in seconds) affects its loudness. Maximum loudness is obtained in about 0.5 seconds, after which there may be a slight decline in loudness as the ear adapts to the sound. For tones of very short duration (about 0.15 to 0.2 second), there is a definite loss of loudness. Low frequency tones lose more loudness than high frequency tones of the same duration.

Duration also affects the pitch. Pitch qualities improve with an increase in duration, up to about 0.1 second.

One- or Two-Ear Hearing. In most people, there is a considerable difference in sensitivity between the right and the left ears, and this difference increases as frequency increases. The difference threshold for loudness is also smaller for both ears than for one ear alone.

When the origin of the tone cannot be seen, the direction from which the sound comes can be identified by the ear alone, although with rather poor accuracy. Subjects tested/2/were able to tell fairly well whether a sound originated to their left or right,

but had difficulty in determining whether it originated in front of them or behind them.

Noise and Performance. Sound is characterized by a regularly repeating wave pattern. Noise, as used here, refers to component sound frequencies that are randomly related (nonperiodic or irregular). The human being's reaction to noise extends beyond the auditory system; it can contribute to such feelings as well-being, boredom, irritability, or fatigue. Some noises may inhibit performance of a job, others may facilitate performance, and still others may have no effect. In general, however, the irritating aspects of noise outweigh its usefulness.

Any increase in noise level above the threshold tends to increase muscular tension and, consequently, the expenditure of energy. For simple or repetitive muscular tasks not requiring fine coordination or precision, noise seems to have little effect, and may improve performance slightly — even when the noise reaches 120-130 db for a short period of time. Work requiring a high degree of muscular coordination and precision, or intense concentration, is adversely affected by noise, but most people accommodate to some extent after a time.

No apparent effect of noise on visual accommodation, perspective, dark adaptation, or distance judgment has been noted. Workers in a noisy environment tend to tire more quickly and become more nervous and irritable than workers in a quiet environment. High-frequency noise is more irritating than low-frequency, and irregularly variable sounds are more irritating than continuously or periodically changing sounds.

Music seems to facilitate performance of simple, repetitive tasks and to decrease accidents; on jobs requiring a high degree of mental effort, it is often distracting. Music's outstanding contribution seems to be in its effect on morale — it can relieve boredom and fatigue, aid relaxation, and improve social relationships. According to polls, manual laborers almost universally approve of music at work.

## SKIN SENSITIVITY AND PROPRIOCEPTION

Basic Concepts and Definitions. As machines become increasingly complex, it is necessary for the operator to utilize all his sense organs to their fullest. The use of the two most important senses, sight and hearing, have long been considered, but it is only recently that the capacity of the skin and the muscular and skeletal systems of the body have been exploited.

Skin sensitivity and proprioception are names for senses that permit us to feel ourselves in our environment. Much of our ability to interpret visual and auditory stimuli is closely associated with the skin senses. Comprehensive information on how these senses affect the reliability of the other senses is lacking, but we do know that the sensory cues received by the skin and muscles can be used, to some degree, to convey messages to the brain and relieve the eyes and ears of part of the load they now carry.

Skin sensitivity includes the ability to discern differences in touch, pressure, vibration, pain, and temperature. In general, it deals with the sensitivity of the body's surface to stimuli.

Proprioception is defined as the means of perception within the body that informs us of the position and movements of the body. Proprioception is divided into kinesthesia (information we receive from movements of the individual parts of the body) and equilibrium (the means of gathering information from the orientation of the body as a whole).

Kinesthesia permits us to judge weights and forces and to identify how far and in what direction an arm or a leg has moved. Equilibrium lets us judge whether the whole body has moved, in what direction it has done so, and how far it has gone.

Influencing Factors. Of the various characteristics of skin sensitivity and proprioception, such as the sensitivity of body parts, stability, and sensitivity to acceleration, vibration, motion, and tilt, we are concerned here only with vibration and discrimination for form as directly applicable to the design of ground electronic equipment. Those interested in the other characteristics mentioned are referred to the material in Part V of the Handbook of Human Engineering Data, Tufts College Institute of Applied Experimental Psychology.

Because vibration causes headache, fatigue, eyestrain, and a general loss of efficiency, designers should be especially conscious of the problem. High-frequency, low-amplitude vibration affects both the mental attitudes and physical aptitude of the operator. For example, tests have shown that vibration reduces visual acuity by an average of 25 percent (the reduction seems to depend upon the vibration at the operator's head). At low frequencies, vision is most affected by vertical vibration. Depth perception fails with frequencies between 25 and 40 and between 60 and 90 cps. Reading speeds are reduced by vertical vibration at low frequencies, and increased illumination is necessary. Seated operators are more affected by vertical vibration; operators in a prone position are more disturbed by horizontal vibration transverse to the axis of the body. Shock mounting of equipment and proper seating and cushions can do much to alleviate the ill effects of vibration.

An important aspect of skin sensitivity is tactual discrimination of form, upon which depends the coding of knobs and handles. Examples of knob shapes that are easily distinguished from each other are found in Figure 7-20.

## MOTOR PERFORMANCE

While the sensory system provides the information that enables the human being to adjust to and control his environment, it is the motor system that actually accomplishes these purposes. This section deals briefly with man's motor capacities and the factors that influence them.

Force. Most jobs require the application of force, and the human being is so organized mechanically that he can exert more force, with less fatigue, if the apparatus has been designed to fit his abilities. Following are some conclusions on the application of force and the strength of body components,<sup>3</sup> which will be of value to the designer.

1. The amount of force that can be exerted is determined by the position of the body and the members applying the force, the direction of application, and the object to which it is applied (see Figure 7-4).
2. The greatest force is developed in pulling toward the body. Thus, controls centered in front of the operator permit the maximum application. Pull is greater from a sitting than from a standing position. A momentary pull can be as great as 250 pounds, while the maximum steady pull is about 65 pounds.
3. The maximum force exertable increases with the use of the whole arm and shoulder, but using only the fingers requires the least energy per given amount of control force applied.
4. Push is greater than pull for side-to-side motion, with about 90 pounds as the maximum.
5. The maximum handgrip for a 25-year-old man is about 125 pounds, and about 103 pounds for a 60-year-old man. The right hand can usually exert an average of 10 pounds greater force than the left. However, controls should not require the maximum force.

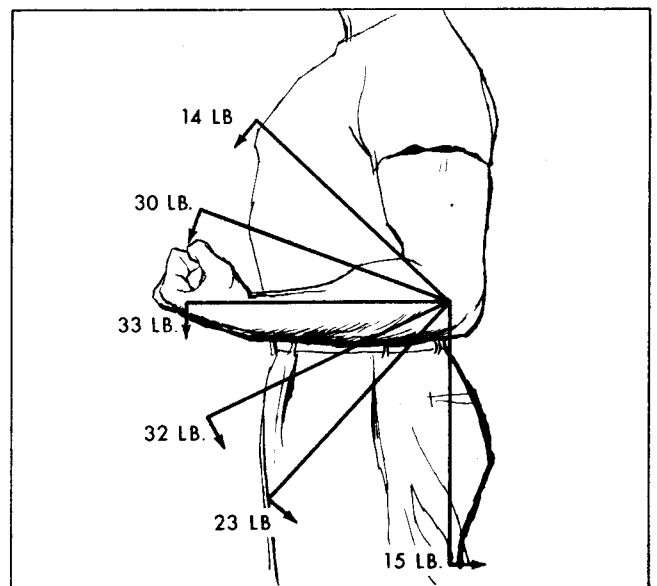

Figure 7-4. Arm force at various positions

6. Force application is equally accurate for hands and feet.
7. Control forces greater than 30 to 40 pounds applied by hand or greater than 60 pounds applied by foot are fatiguing.
8. Leg strength is second only to postural strength. Force in extending is greater than in bending. The maximum force with backrest is about 450 pounds for short periods. The "throwoff" — the point at which the leg ceases to function alone and other body components begin to operate — occurs at about 40 pounds without backrest, 60 pounds with backrest.
9. With the knee at a right angle, strain begins at about 28 pounds with backrest, 50 pounds without backrest. At an angle of 45 degrees from the vertical, thrusts may rise to about 155 pounds.
10. Leg and arm strength reach their maximum about the age of 25 and decline about 50 percent from 30 to 65 years. Hand strength declines about 16.5 percent during this period.

Reaction Time. The speed with which we react to a stimulus is, among other things, dependent upon:

1. The sense to which it is presented. Auditory reaction time is generally faster than visual reaction time.

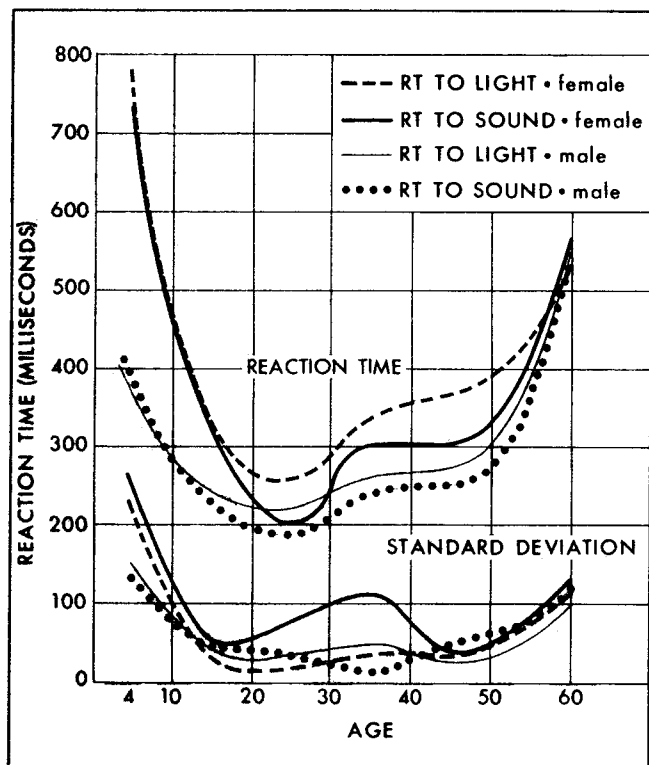

Figure 7-5. Variation in reaction time with age

2. The stimulus intensity. Greater stimulus intensities, up to a definite limit above threshold, decrease reaction time; above the limiting intensity, no reduction in reaction time may be expected.
3. Practice. Simple reaction time may be reduced as much as 10 percent by practice.
4. Preparedness. "Ready" signals reduce reaction time.
5. The motor unit responding. For right-handed people, the right hand and foot are faster than the left, and vice versa for left-handed people.

The physical and mental condition of the human being is, of course, of great importance. Figure 7-5 shows the variation in reaction time (RT) with age.

Speed of Movement. Research and experience have demonstrated the following facts about man's ability to move parts of his "machinery."

1. The hand can move faster horizontally than vertically. Right hands function better for horizontal counterclockwise motion, left hands for clockwise motion.
2. Continuous curved motions are faster than those that have abrupt direction changes.
3. The time required to perform a movement increases with the length of the path, but the time required to start and stop a movement, regardless of its length, remains fairly constant.
4. The maximum velocity is in inverse relation to the weight of the load moved, and the time required to reach maximum velocity varies directly with the load.

Precision. Precision is the exactness with which a response can be made, and involves both the smoothness and the accuracy of the total motion.

Tremor is the oscillation resulting from the effort to maintain a fixed position or direction. Tremor decreases when the work is against friction, when the member is supported, and when the body is well supported while the member performs the activity. Tremor increases when effort is made not to tremble and when fatigue is present. It is greatest in vertical movements, less in front-to-back motions, and least in side-to-side movements.

Effects of tremor are shown in Figure 7-6. Note that motion at 135 and 315 degrees results in the greatest precision.

The accuracy of motor control systems is greatly decreased by the lag between control movement or force and the time of display of the resultant of that control movement. Even a few milliseconds lag is enough to cause serious disruptions.

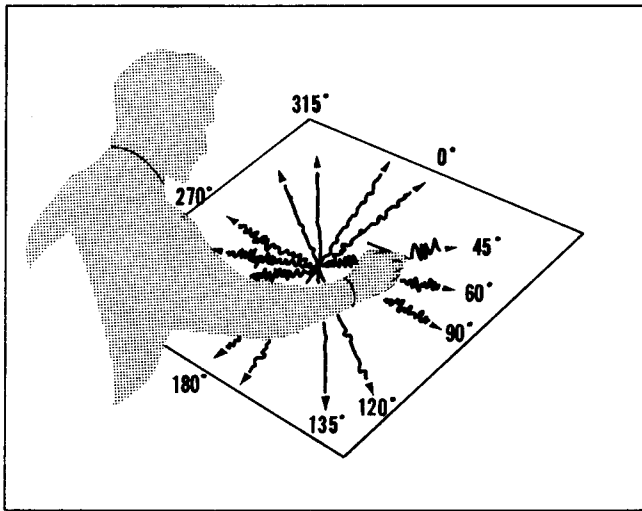

Figure 7-6. Effects of tremor

#### Factors Influencing the Basic Characteristics.

Acceleration, rest periods, "pacing," and mental and physical factors all have an influence, in varying degrees, on the basic characteristics of motor performance. Because individual reactions to these factors differ greatly, and because relatively few conclusive studies have been made in this area, generalizations are difficult.

Principles of Motion Economy. The following principles /4/ of motion economy increase the ease, speed, and accuracy of manual operations.

1. The best motion sequence is the one employing the fewest basic separations of movement.
2. Continuous, curved motions are better than straight line motions involving sudden, sharp changes in direction.
3. Successive movements should be so interrelated that each ends in a position favorable for the beginning of the next.
4. For smooth and automatic performance of an operation, the work should be arranged to permit easy and natural rhythm. Hesitation of motion should be eliminated wherever possible.
5. A movement is less fatiguing if made in the direction in which gravity can be utilized.
6. A free-swinging movement is faster, easier, and more accurate than a restricted or controlled movement.
7. When a powerful stroke is required, the movements of the operator should deliver the stroke at its optimal momentum. If it must be brought to a stop by muscular effort, however, the momentum should

not exceed the least amount required to deliver a sufficiently powerful stroke.

8. Arm movements should be made simultaneously, and in opposite and symmetrical directions.
9. Both hands should begin and finish their motions at the same instant.
10. The hands should not be used for work that can be better performed by the feet or other parts of the body.
11. Wherever possible, the hands should be freed by holding work in jigs or vises.
12. Searching and selecting should be eliminated by pre-positioning tools and materials. Two or more tools should be combined wherever possible.
13. The height of the work place and the chair should be arranged so that the operator can alternate between sitting and standing.

#### BODY MEASUREMENT

To design equipment for the most efficient use by the operator, the engineer requires, among other things, information concerning the dimensions and movement limitations of various parts of the body. To this end, this section incorporates all data important for giving a picture of the entire body structure and of the limbs and their relation to the rest of the body.

Although physical measurements are generally more reliable than psychological measurements, the figures in this section should not be accepted as absolute. Most of the data were obtained from measurements of males in various service groups during World War II, and it must be remembered that these men were not accepted if they exceeded certain specified maximum and minimum measurements. Thus, the figures are not the same as for an unselected population group, but the error probably is not great.

A second point to consider is that body measurements by themselves offer no absolute index of capacity. For example, the overall physical structure, regardless of specific dimensions, has a strong effect on the individual's capabilities and limitations. For information on the three most common body types (endomorph, ectomorph, and mesomorph) and their characteristics, the designer is referred to The Variety of Human Physiques, which is listed in the bibliography at the end of this chapter.

Another point to bear in mind is that a list of physical dimensions alone cannot be applied directly to a design problem. The interaction of the various parts of the body must also be taken into account. Refer to Tables 7-1, 7-2, 7-3, and 7-4.

Table 7-1. Weights (in pounds)/5/

Type of subject	Central tendency	Range
Cadets	*153.1	110-210
Gunners	*147.1	108-203
Civilians (clothed)	*166.7	100-309
Enlisted men (clothed)	160.0	100-280
Fighter pilots	153.2	125-185
Bomber crews	155.6	106-210

\* The first three items represent the median score (50 percent of the cases lie above, 50 percent below); the last three items represent the arithmetic mean (the sum of the scores divided by the number of cases).

Table 7-2. Body measurements for the adult male (in inches)/5/

(Note: parenthesized numbers refer to measurements in Figures 7-7.)

Dimension	Type of subject	Central tendency	Range
(1) Abdominal depth	Cadets	8.20	6.3-10.6
	Gunners	8.20	6.3-14.2
(2) Anterior arm reach	Cadets	35.20	29.5-40.6
	Gunners	34.80	29.5-39.0
(3) Bi-deltoid	Cadets	18.00	15.4-20.5
	Gunners	17.70	15.4-19.7
(4) Bi-iliac	Cadets	11.40	9.1-13.4
(5) Bi-trochanteric	Cadets	14.02	11.8-18.5
(5a) Hip breadth (clothed, seated)	Civilians	15.30	12.0-21.3
(6) Buttock to knee	Cadets	23.60	19.3-27.6
	Gunners	23.10	20.1-25.6
(6a) Seat Length	Civilians	18.90	15.4-23.1
(7) Chest circumference (rest)	Cadets	35.70	30.7-43.3
	Gunners	25.40	30.7-40.9
	Fighter pilots	*36.20	32.9-42.9
(8) Chest depth	Cadets	8.20	6.3-11.0
	Gunners	8.20	5.9-10.6
(9) Crotch height	Aviation cadets	*32.38	not stated
(9a) Leg length	Aviation students	*41.10	not stated
	Navigators		
	Bombardiers	41.10	not stated
(10) Elbow to seat	Civilians	9.60	6.7-12.0
(11) Foot length	Cadets	10.50	8.8-12.2
	Gunners	10.40	9.0-11.8



Table 7-2. Body measurements for the adult male (in inches)/5/ (Cont)

Dimension	Type of subject	Central tendency	Range
(12) Height (with heels)	Cadets	69.20	61.4-78.0
	Gunners	67.90	59.4-74.3
	Civilians	69.00	59.0-80.0
	Enlisted men	* 69.10	58.0-78.0
	Fighter pilots	* 68.60	65.0-73.5
	Bombers crews	* 68.70	62.0-77.0
(13) Patella height (lower leg length)	Cadets	22.00	18.1-25.6
	Gunners	21.50	17.7-24.4
	Aviation students	* 21.50	not stated
	Navigators		
	Bombardiers	* 21.20	not stated
	Aviation cadets	* 21.10	not stated
(13a) Seat height	Civilians	19.00	15.6-22.0
(14) Shoulder to elbow	Cadets	14.70	10.6-16.9
	Gunners	14.50	12.2-16.5
(15) Sitting height	Cadets	36.40	32.7-40.6
	Gunners	35.90	32.3-39.4
	Navigators		
	Bombardiers	* 36.50	not stated
(16) Span — akimbo	Cadets	37.10	31.9-42.5
	Gunners	36.50	31.1-41.7
(17) Total span	Cadets	71.50	62.2-80.7
	Gunners	70.50	60.6-79.5
(18) Trunk height	Cadets	23.80	19.7-27.2
	Gunners	23.30	20.1-26.0
(18a) Back height	Civilians	28.60	23.6-33.1

\* Indicates items scored according to the arithmetic mean; all other values are median.

Table 7-3. Head measurements for the adult male (in inches)

(Note: parenthesized numbers refer to measurements in Figure 7-8.)

Dimension	Type of subject	Central tendency	Range
(1) Bi-tragion	Cadets	5.70	4.88-6.30
	Enlisted men	5.57	4.76-6.61
(2) Breadth	Cadets	6.06	5.44-6.76
	Enlisted men	6.02	5.28-6.90
(3) Chin to neck projection	Cadets	1.83	1.06-2.69
	Enlisted men	1.90	1.02-2.91
(4) Circumference	Cadets	22.40	20.0-24.4
	Enlisted men	22.22	19.8-24.3
	Gunners	22.20	2.00-24.0
	Bomber crews	22.29	20.4-24.0
	Fighter pilots	22.63	21.5-24.1
(5) Ear length (maximum)	Cadets	2.56	2.04-3.11
	Enlisted men	2.52	1.93-3.07

Table 7-3. Head measurements for the adult male (in inches) (Cont)

Dimension	Type of subject	Central tendency	Range
(6) Head height	Cadets	5.14	4.33-5.84
	Gunners	5.10	4.49-5.78
(7) Interpupillary	Enlisted men	2.47	1.85-1.93
(8) Head length	Cadets	7.78	6.78-8.59
	Enlisted men	7.68	6.50-8.59
	Bomber crews	7.74	6.97-8.50
(9) Mouth breadth	Cadets	2.04	1.65-2.50
	Enlisted men	1.97	1.42-2.50

Hand grasp dimensions are shown in Figure 7-9. Other dimensions are shown in Figure 7-10.

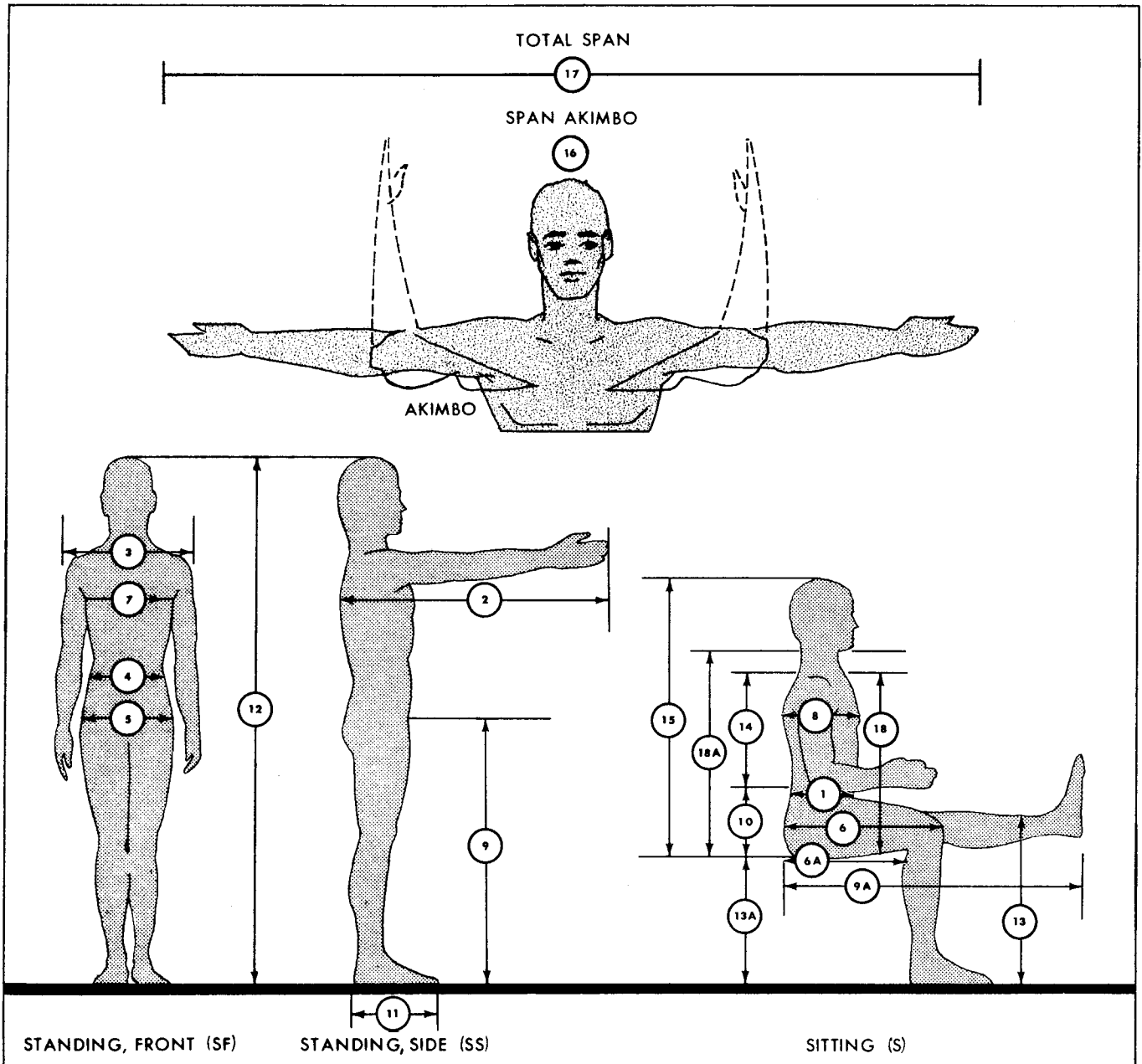

Figure 7-7. Body measurements

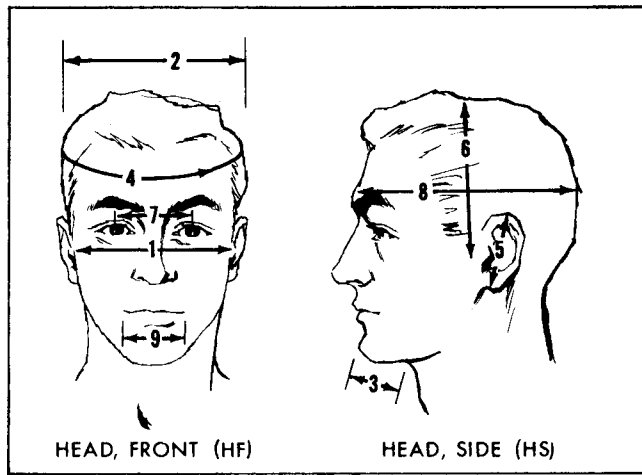

Figure 7-8. Head measurements

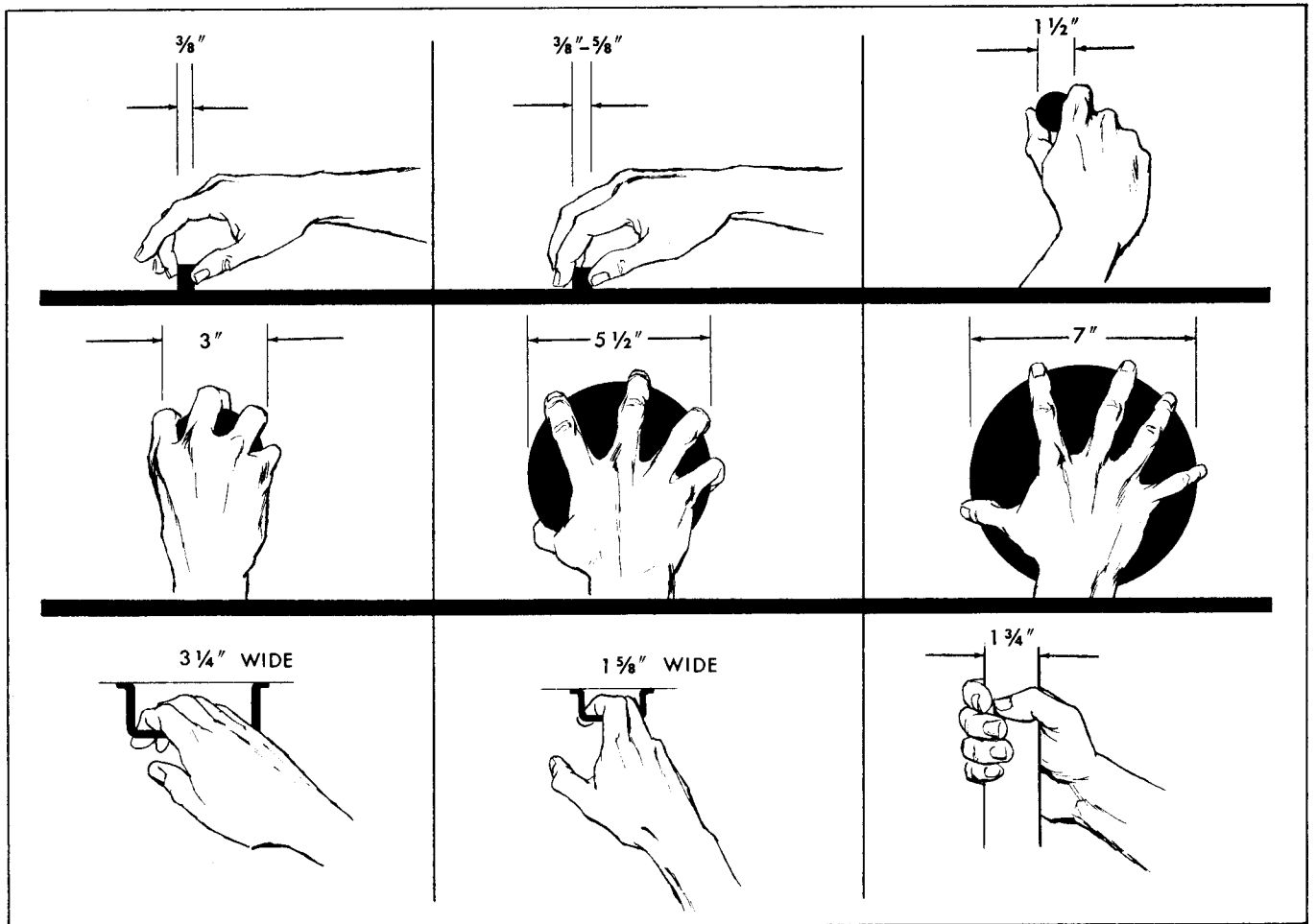

Figure 7-9. Hand grasp measurements

Table 7-4. Stature-weight-age averages (men)/6/

Height		Age												
ft	in.	16	17	18	19	20	21	22	23	24	25-29	30-34	35-39	40-44
5	0	101	103	105	107	110	112	114	116	118	122	126	128	131
5	1	106	108	110	112	115	117	119	121	123	124	127	130	133
5	2	111	113	116	117	120	121	122	123	124	126	130	132	135
5	3	115	117	119	121	124	125	126	127	128	129	133	135	138
5	4	119	120	122	124	127	128	129	130	131	133	136	138	140
5	5	124	125	126	128	130	131	132	133	135	137	140	142	145
5	6	128	129	130	132	133	134	135	137	139	141	144	146	149
5	7	133	134	135	136	137	138	140	141	143	145	148	150	153
5	8	137	138	139	140	141	142	144	146	147	149	152	155	158
5	9	141	142	143	144	145	147	148	150	151	153	156	160	163
5	10	145	146	147	148	149	151	153	155	156	157	161	165	168
5	11	150	151	152	153	154	156	158	160	161	162	166	170	174
6	0	155	156	157	158	160	162	164	165	166	167	172	176	180

Weight

**APPLICATION OF HUMAN ENGINEERING PRINCIPLES**

The previous sections of this chapter presented a brief account of the practical limits of human performance and sensitivity. In this final section, we offer the engineer certain suggestions and recommendations applicable to most equipment and system designs.

General Concepts. The design of equipment and layout of work space must of necessity be the result of a compromise among the various factors involved — mechanics, circuitry, architecture, and the human being who is an integral part of the system. These compromises are of various degrees of practicality — some are based on well-established principles of human engineering, while others are tentative and require further exploration and verification. Specific design recommendations are given where possible, and more general ones where the variations resulting from too many factors would require a design to fit each individual problem.

A word of caution is in order concerning the sometimes conflicting concepts of practicality and esthetic values. The location of equipment purely on the basis of engineering practicality may be quite undesirable from the operator's point of view and should be avoided. At the same time, designing and laying out equipment for the sake of symmetry, balance, and similar considerations is undesirable if any of these esthetic values interfere with the

needs and duties of the operator and other human-engineering necessities.

Layout of Instrument Panels. There is no simple solution to the complexities of panel design, particularly because of conflicting priorities. The type of presentation must be determined, the location of indicators and controls must be balanced against the need for adjustment, the best means of illumination — floodlighting, internal, spotlighting, and colored lighting — must be decided upon, and so on.

The designer should ask himself before each decision, what use the operator will make of each piece of equipment, and how its location will help him perform the necessary task with the most accuracy and least fatigue. The designer should try to imagine himself in the operator's position and visualize the tasks he must perform, the need for precision, the effect of errors, the problems of seeing and reading, and the interrelation of operations. In all decisions, the needs and duties of the operator should be paramount.

Arm reach is one of the most important considerations in the design of work areas (see Figure 7-11). According to the best available statistics, the designer should consider 28 inches as the maximum arm reach (see the material on body measurement in this chapter). The vertical panel makes more area available with less crowding. Visibility may be slightly impaired, but glare is often reduced. The ideal layout in terms of visibility would be one in

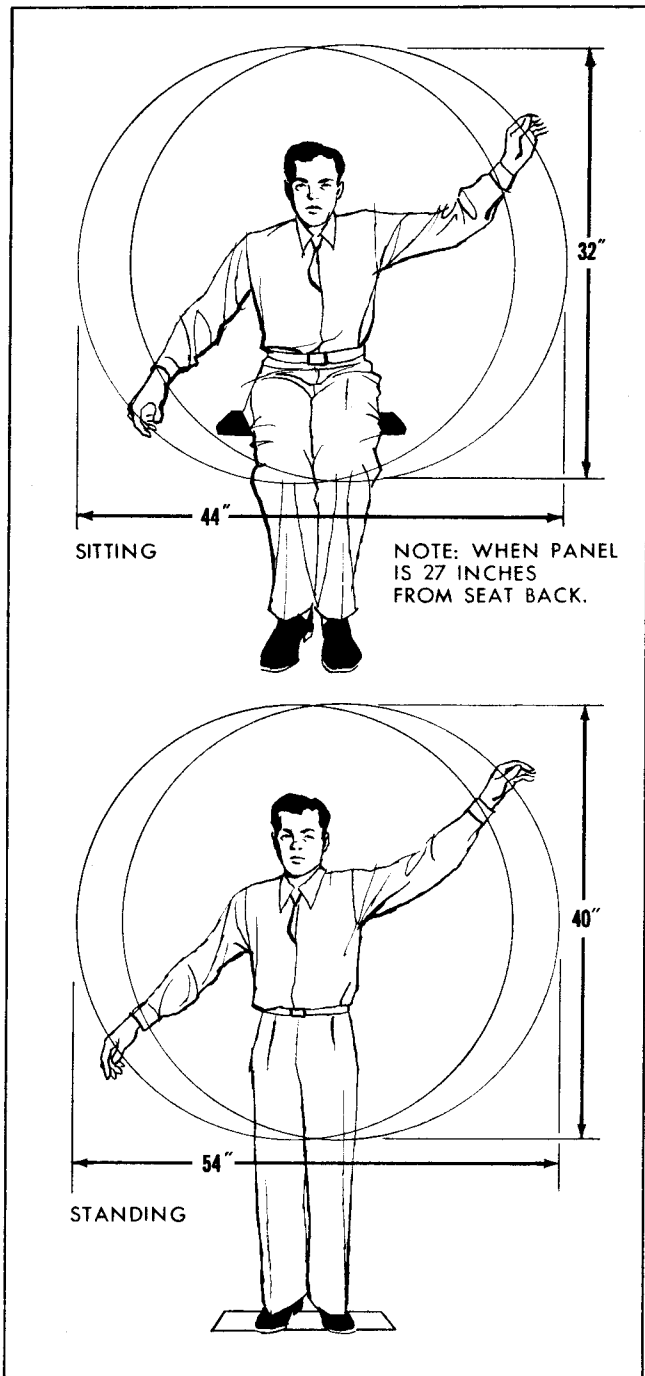

Figure 7-10. Ranges of convenient arm movement from a static position

which the angle of panel plane followed the arc of eye movement. Since this is rather impractical, the next best is a vertical layout with wing panels for side areas and horizontal panels for extreme lower portions.

In planning a specific panel, the first step should be, wherever possible, to divide all the switches, controls, and indicators related to one activity into separate groups. For example:

Group A

PPI scope  
PPI controls  
Focus and intensity  
Range cursor  
Video gain

Group B

Speaker  
Controls  
Audio gain control  
Output meter  
Frequency selector

Group C

Intercom controls  
Phone jacks

Group D

Navigation instruments  
Compass  
Course indicators  
Controls

Group E

Check reading instruments  
Manifold pressure  
Engine temperature  
Oil pressure  
Fuel gauges

Ideally, this arrangement should form an integrated, interrelated unit, with the information so presented that the operator needs to do only a minimum of organizing and reaching to control the situation. Functional areas should be marked out with lines of appropriate contrast to the background. Demarcation lines should be used only for the major groups. However, too many lines negate their purpose.

The next logical step should be to select the groups used most frequently and place them as near the center of the panel as possible. Compromises and adjustments will, of course, have to be made — visual indicators require optimum positions, while the operator can attend to aural indications without facing the source. /7/

In experimenting with various arrangements of patterns, the designer should keep the following points in mind.

1. Visual displays should be placed in central areas. The most important indicators should be in the most prominent positions and at eye level; those watched only during certain operations can be grouped farther from the center. A horizontal layout is best, as the eye scans horizontally more effectively than vertically.
2. Each control should be as close as possible to its related indicator, and in the same plane. Simultaneously-operated controls should be so placed that the operator will not have to cross or interchange hands or have his vision obscured.
3. Pilot lights should be located near the top right-hand corner of a control panel, and their switches should throw toward the light when on.
4. Warning lights should be located as close as possible to the central line of sight.

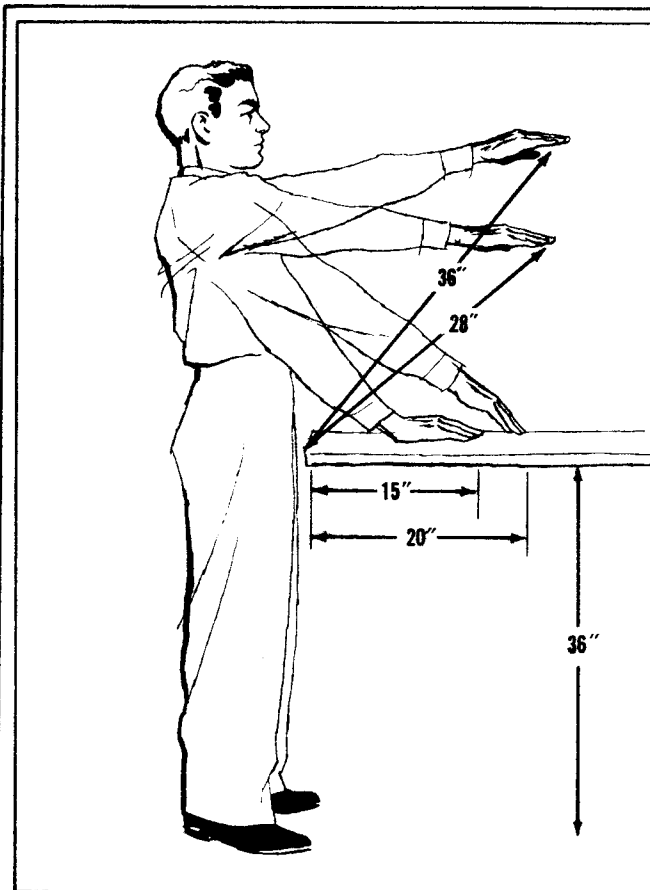

(A)

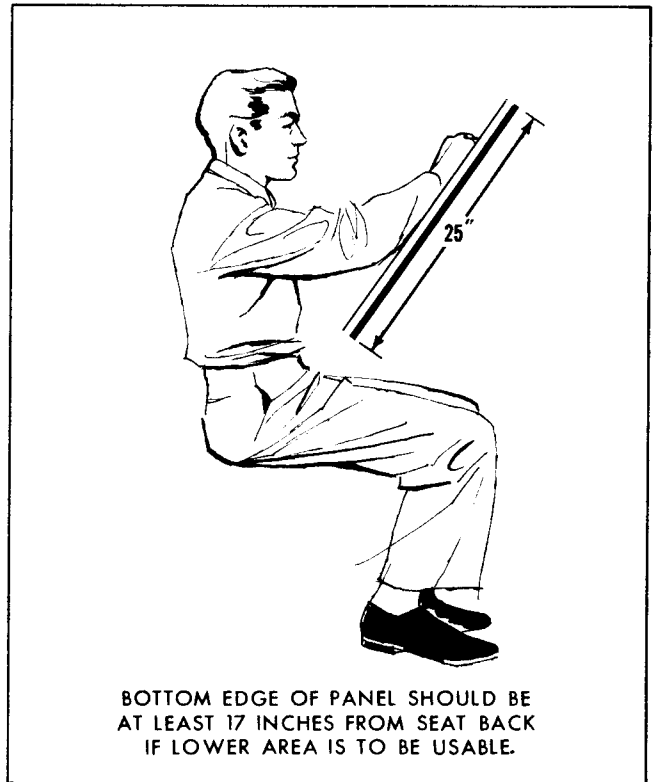

(B)

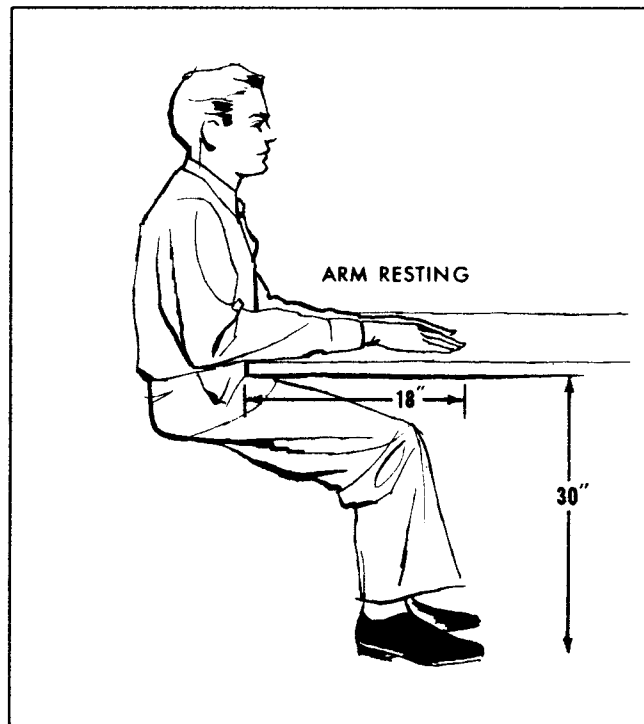

(C)

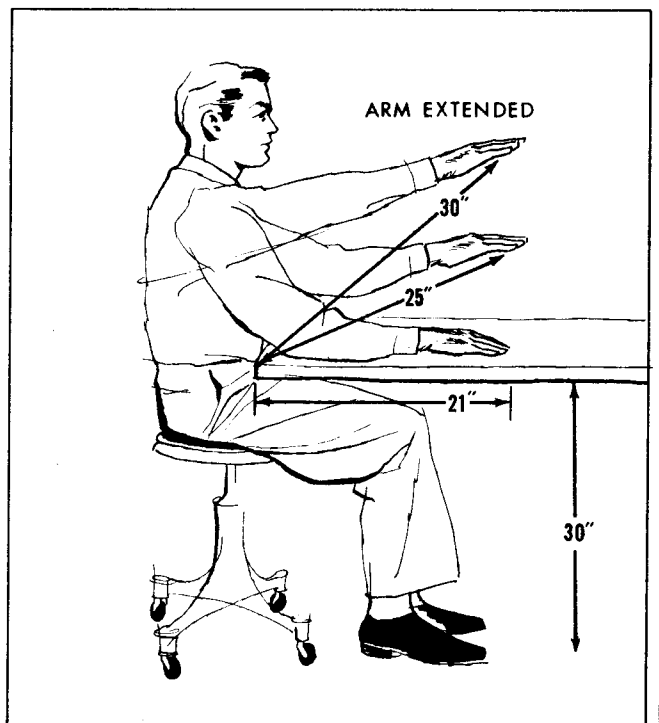

(D)

Figure 7-11. Ranges of convenient arm reach for typical working positions

A pattern display of warning lights is recommended. Experiments have shown that a combination of doughnut and bar shapes make the display more discernible than the parallel-bar arrangement.

5. Phone jacks should be placed on the lower edge of the panel, and the phone cords should not interfere with operating controls.
6. No more than two controls of the same shape should adjoin.
7. Seldom-used controls may be covered.
8. When two or more speakers are used to provide information from different sources, they should be mounted at ear level and separated as much as possible.
9. No switches or controls should be mounted in such a manner as to invite accidental displacement.
10. Reflecting surfaces and metal dials should be treated for glare, and painted surfaces should be given a dull or mat finish.

Visual Indicators. Too often in the past, the problems of instrument design were considered only in terms of mechanics. The visual display, as presented to the operator, was of secondary importance — "the operator can learn to live with it." This attitude naturally resulted in the design of many instruments that were unnecessarily complicated and confusing and that reduced accuracy and efficiency.

In selecting or designing a visual indicator, the engineer should first decide what kind of information is desired and what type of display will most efficiently provide this information.

For quantitative information — to indicate numerical values — scales or counters are used. Research in quantitative reading has shown that two types of reading errors occur. Prevision error results from such factors as inaccuracy in interpolating pointer position between graduation marks, parallax, and poor definition of the pointer and markings. This can be corrected somewhat by expanding the scale or increasing the number of graduation marks.

Interpretation errors are more serious and occur more often than errors stemming from difficulties in legibility or acuity. The error may be large, often in multiples of 1,000 or 10,000 units. Many of these errors have been traced to reversed reading of the scale, that is, the scale reads counter-clockwise or from right to left, both of which are wrong.

For qualitative information — to indicate position relationships — pictorial displays are used.

For both quantitative and qualitative information, scales or counters are used in combination with pictorial displays (see "Combined Displays").

Specifically, to provide information on:

1. Aximuth — use a circular scale that indicates the quadrants as well as numerical values.
2. Rate — use a circular scale that indicates, in addition to numerical approximation, the relative acceleration and deceleration.
3. Time — use a circular scale or counter. The circular scale has the advantage of keeping the operator oriented to the complete time cycle.
4. Height-depth — use a vertical straight line scale that gives relative direction and proximity to zero. Most present designs do not meet these specifications.
5. Temperature — use a vertical straight line scale that orients low vs. high positions.
6. Frequency range — use horizontal straight line scales that present an appropriate pattern for comparison.
7. Range (yards, miles, and so on) — use a counter. This recommendation is qualified to the extent that the counter is best where numerical accuracy is necessary; a combination of cathode-ray tube and counter will provide the most accurate means of interpretation.
8. Attitude — use a pictorial representation. (See Figure 7-12.)
9. Tracking — use a pictorial representation. (See Figure 7-13.)

Scales and Dials. Circular scales (dials) and linear scales give good quantitative information and also a certain amount of qualitative information. A dial with a fixed face and a moving pointer is better than one with a moving face and a fixed pointer.



Figure 7-12. Attitude presentation

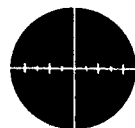

Figure 7-13. Tracking presentation

The diameter of a dial face should be between 1 and 4 inches. For checkreading a group of instruments, dials of 1 3/4 inch diameter are good. Uniform pointer alignment is especially recommended for checkreadings, as the operator can quickly detect any indications of malfunction. In terms of speed of response and freedom from error, the 9 o'clock position is best, the 3 o'clock position worst. (See Figure 7-14.) Increase should be in a clockwise direction.

Linear scales can be used horizontally or vertically. If the scale is to indicate numerical values only, the moving scale with a fixed pointer is recommended, as the eye is able to find the pointer easily in the center of the display. If some qualitative indication is also desired, the moving pointer on a fixed scale is considered superior because of its ability to indicate relative position.

Scale Markings. The faster a scale must be read, the fewer should be the marks on it. If accuracy requires more and finer markings, the reading time must be lengthened.

Numerals and Letters. The critical detail that distinguishes one number or letter from another should be as large as is consistent with legibility. Letter styles similar to LeRoy lettering guides or Army-Navy Standard AND10400 are easily available and adequate for discernment. Capitals can be seen at a greater distance than lower case letters but are not so quickly recognized. Recommended stroke dimensions are as follows./8/

Dimension	Minor	Intermediate	Major
Length	0.09375 in.	0.125 in.	0.1875 in.
Stroke width	0.015 in.	0.020 in.	0.025 in.

In general, the larger the number or letter, the less contrast and illumination required. In daylight, a black figure on a white background is superior (ratio of stroke length to width, 6 to 1). Under ordinary night conditions (medium dark adaptation), luminous numbers at threshold brightness are about

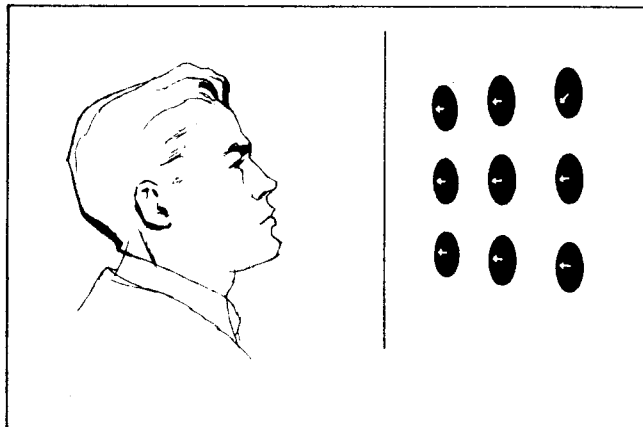

Figure 7-14. Layout of a group of instruments

20 percent more recognizable than white numerals with reflected light. Numeral height-to-width ratio ordinarily is about 3 to 1. For information on transilluminated panels, see "Illumination," later in this chapter.

Quadrant orientation on circular dials may be improved by making figures larger at key positions. Numbers should be placed to read in the expected direction. They should increase clockwise on circular scales, and from left to right or from bottom to top on linear scales.

Stationary numbers should be oriented vertically. Numbers appearing at open windows should be in an upright position.

Scale Indices. The minimum spacing between major divisions should be about 0.5 inches. Unit spacing can be from 0.04 to 0.06 inch. The smallest readable division on a scale should be equal to the probable error of the apparatus in terms of quantity read on the indicator. Scale marks should not be long enough to cause a stereoscopic effect (periodic changes in intensity). Recommended stroke distances are given below./8/

Dimension	Minor	Intermediate	Major
Length	0.09375 in.	0.15625 in.	0.21875 in.
Stroke width	0.015 in.	0.020 in.	0.025 in.

Optimal number intervals are 1-5-10-100. The fewer digits the better.

Pointers. The tip of the pointer should come within 1/64 to 1/32 inch of the scale markers, but should never overlap the markers. The tip width should be the same as the thickness of the scale marker. A pointer (Figure 7-15(a)) 3/32 of an inch wide can easily be seen under natural or artificial light.

When a diamond-shaped "bug" pointer (b) is used, its tip should come within the same distance from the markers as a pointer. The bug should contrast with its background and be large enough to attract attention. Important moving components, such as a bearing indicator, should be large enough to be seen quickly.

When transilluminated (edge-lighted) dials (c) are used for dim-out conditions, a fluorescent or clear plastic disc with pointer engraved on it should be used, and it should rotate inside the scale ring. Engravings should be on the inside diameter of the dial ring.

Counters. The following details of counters and how best to use them are the results of considerable study from the human-engineering standpoint.

Numerals. Height-to-width ratio of numbers should be 1 to 1, and stroke length-to-width ratio 6 to 1. The contrast between the number and its background should be at least 60 percent.



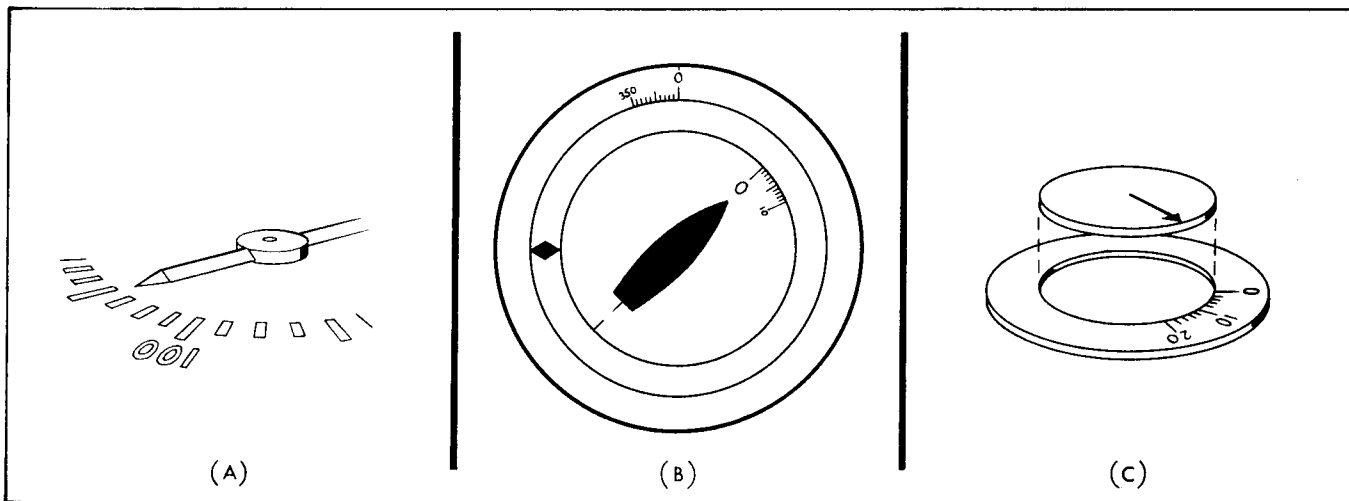

Figure 7-15. Pointers

Black letters on white are best for high levels of illumination, and white letters on black are recommended in situations requiring dark adaptation. Red on black is not advised, unless there is enough space for very large numbers.

**Meaningful Digits.** Where the last digits have little value, as in range, it is sometimes advisable to substitute stationary zeros to avoid confusion. Where the initial digits are not used for long periods of time and it is confusing to have meaningful digits preceded by zeros, it may be advisable to cover these unused zeros by means of a mechanical blanking-out shield. (See Figure 7-16.)

**Frame.** The frame should be designed so that parallax is eliminated, and the color should be the same as the background color of the pointer.

**Mounting.** On counters mounted above eye level, the numbers should increase from the top, so that each succeeding number can easily be seen as it comes into view. For counters mounted below eye level, the numbers should increase from the bottom. Where a counter rotates in both directions, the numbers should increase from the top and the counter should be mounted as close to eye level as possible, or within the direct line of sight when the panel is inclined from the vertical.

**Pictorial Indicators.** These provide information that requires a fairly realistic representation of the elements involved. Completely realistic detail is almost never attained, however, and the designer must decide on the comparative importance of realism, spatial relationships, and quantitative information.

**Electronic Indicators.** Equipment such as radar or sonar make use of the cathode-ray tube (CRT) for pictorial realism, and of grid lines, electronic markers, scales, and counters for quantitative information. The efficiency of the CRT display depends on several factors.

1. Size of tube. A tube face 5 to 6 inches in diameter is usually satisfactory at normal reading distances.
2. Viewing angle. The best visibility is obtained where the line of sight is perpendicular to the scope face. The mounting angle of the scope is not critical within a range of 0 to 90 degrees, if the operator can maintain proper line of sight within the scope face. A vertical screen is recommended for most cases.
3. Viewing distance. The best viewing distance is between 14 and 20 inches. Visual acuity is better at short distances, but any background noise tends to offset this advantage.
4. Brightness levels. The bias should be adjusted to less than cut-off, so that the visible noise is on the order of 0.1 ft-candle. The gain should be near maximum. Variation in tube conditions makes it impossible to provide exact limits. When screen brightness is on the order of 0.5 ft-candle, a negative, or "dark," pip produces greater detectability. Such a negative signal may be produced on PPI's by reversing the signal leads.
5. Shape of frame. An A-scan type of display should have a square or rectangular frame, while the PPI type should have a circular frame.
6. Markers and guides. An operator can adjust an electronic or mechanical marker more accurately than he can estimate a target position. Azimuth markers should be designed to feed selected position information to a counter, which will give exact quantitative readings.

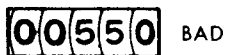
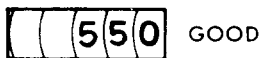

Figure 7-16. Good and bad methods of presenting digital information

Where estimates are necessary, lubber or grid lines are recommended. Parallel guidelines that can be rotated mechanically can be used successfully for estimating approximate ranges and bearings on a PPI-type display. This type of grid or line should be designed to extend the full diameter of a tube face (Figure 7-17). All guidelines should be as fine as possible, to maintain a position of secondary importance with respect to the target information. Such lines should be used with discretion, however, as too many lines tend to confuse the display.

**Mechanical Indicators.** Mechanical indicators combine the use of fixed scales and lubber lines with gyrocontrolled silhouettes and the like. Three factors should be considered in the design of these instruments.

**Relative Motion.** A decision must be made as to what part or parts of a display should move, and how it or they should move with respect to the other elements of the display. The terms "inside-fixed" and "outside-fixed" have been suggested by the U. S. Navy Electronics Laboratory. An inside-fixed display is one in which the operator position is fixed and information about other factors is indicated by moving parts (such as the shipboard gyrocompass repeater). It should be used whenever the operator wishes to check the action of something relative to himself, such as the display of a transducer or antenna train.

An outside-fixed display shows how the operator moves within a fixed area (such as the artificial horizon of the type in which the silhouette moves and the horizon remains fixed with respect to the instrument panel). The operator understands the picture better when he moves the model of himself about in the fixed frame of reference that is the instrument.

**Spatial Dimension.** Dimension in space has been successfully displayed in a qualitative sense, but not in a quantitative sense, as the pictorial display tends to strive for such realism that quantitative evaluation of the information is almost impossible. The designer must therefore determine whether realism or quantitative information is the more important. An example of combining both qualitative and quantitative information is shown in Figure 7-18. The artificial horizon in (a) gives a qualitative indication of climb or dive, but (b) shows a suggested method of giving both qualitative and quantitative information.

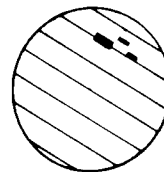

Figure 7-17. Gridlines on PPI displays can aid in estimating ranges and bearings

**Realism.** Although realism is not quantitative to any accurate degree, a certain realism is possible that automatically includes the quantitative information in such a way that the operator can manipulate the display by means of control adjustments without concerning himself with numerical values. This type of display is illustrated by the Bendix VHF navigational instrument, shown in (c), which presents all the information of the plane's attitude (d).

**Combined Displays.** Displays may be combined in two ways — having two or more types of information within one instrument, or two or more instruments grouped in an area pattern. For instance, counters may be used in conjunction with scalar indicators to give very precise readings or a wide range of scale; the circular dial with pointer acts as a cue to the area of precise reading, while a linear system aids in determining the direction of movement (whether the numbers are increasing or decreasing).

When displays are combined within one instrument, the overall picture of a situation is usually enhanced, a saving in space is often achieved, and the extent of eye movement is reduced.

Combining displays in one instrument has certain disadvantages: confusion may result from too much information on one instrument, large instruments often occupy more space than several small ones, and large illuminated dials or scopes may aggravate the overall lighting problem and make even illumination of the whole panel difficult to achieve.

There are certain advantages to be gained from combining displays in groups. Overall orderliness is desirable, both esthetically and functionally, easy unit replacement simplifies maintenance, and integral groups are easily recognized because of patterning.

The disadvantages of combining in groups are these: the size and shape limitations of a particular panel may make logical grouping impossible, certain instruments may have to be used with more than one group, controls for groups may have to be placed in poor operating positions, and several groups may compete for priority position on a panel.

**Pilot Lights.** The size of pilot lights should be kept as small as possible. The "grain-of-wheat" type is recommended for many installations. Where 6-volt bulbs are required, it is suggested that they

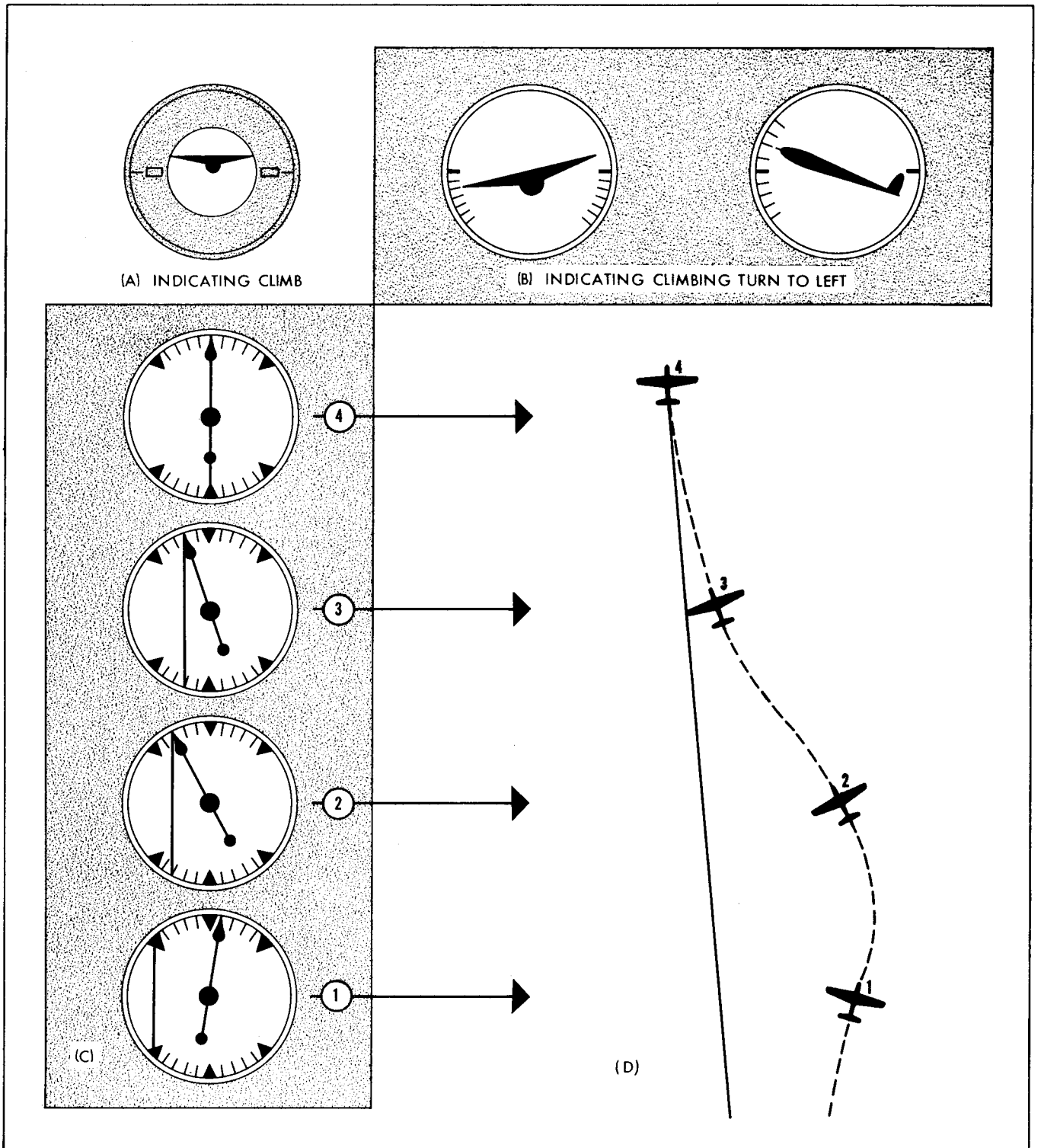

Figure 7-18. Spatial displays

be operated at only 5 volts, as the filament will burn at a lower color temperature, which reduces the filter problem and also extends the life of the bulb. The apparent brightness of emitted light should be approximately twice the ambient room light (from 0.01 to 0.1 ft-candle).

A red filter, similar to Wratten No. 29, should be reserved for power pilots wherever possible. When dark adaptation is necessary, pilot lights of any other color should be as close as possible to the red, such as, red-amber or reddish-purple. When printing is used, the numbers or letters should subtend a minimum visual angle of 5 minutes at the eye. At a distance of 30 inches, this would appear about 0.2 inch. Such printing should have maximum brightness contrast — at least 60 percent — for both day and night viewing.

Warning Lights. Warning lights should be at least as bright as the brightest light source in a given situation. Operator response is usually faster under nighttime conditions than under daytime conditions. The optimum flash rate for flashing warning lights has not been definitely determined. Three flashes per second have been used in the past, but the U. S. Navy Electronics Laboratory has proposed a flash rate of 8 or 9 per second.

Red lights can be correctly identified at a greater distance than those of other colors, because they tend to appear as white at long distances. Blue lights are satisfactory only at short distances. Red lights are more effective than green, and green more effective than amber.

For limits of normal color differentiation with both eyes oriented straight ahead, see Figure 7-2.

Illumination of Visual Indicators. Numbers and indices should appear black on a white background (mat finish) under daylight conditions, and red on black under nighttime conditions. When red markings on black background (illuminated) are used, the brightness level should be on the order of 0.009 to 0.018 apparent ft-candle.

All indicator faces should be uniformly and equally illuminated. Where the instrument faces on a single control panel are of different sizes, separate illumination-level dimmers should be used to equalize the overall brightness of the area. A combination of indirect and flood lighting should always be the same color.

Where dark-adaptation is necessary, monochromatic red light is recommended, although distinct vision is not possible much over 13 inches from the instrument. (Among monochromatic lights in general, however, yellow provides the best acuity.) Also, color coding is rendered impractical, because colors lose their identity under red light.

Visual acuity may be increased slightly by keeping the room lighting at an extremely low level, but this tends to induce fatigue. Since the operator

cannot be completely dark-adapted in the presence of a scope, ambient light of approximately 0.01 ft-candle is considered satisfactory. Background brightness equal to screen brightness may even improve legibility by helping to maintain uniform adaptability.

Glare or shadow can be avoided by glare-coating the glass or plastic instrument covers and by mounting the cathode-ray tube face as nearly flush with the control panel as possible. The effects of ambient light and glare are more serious with the PPI than with the A-scan type of scope.

External Lighting. Although satisfactory for seeing, external lighting of visual indicators requires a high-level source and therefore produces glare, particularly when the source is red light for dark adaptation. High-intensity lamps with red filters can be placed outside the instrument to be illuminated, but great care must be taken to locate the lamps correctly to get uniform illumination. The most serious disadvantage is that a large quantity of stray light from the lamps and the reflected glare are difficult to avoid. Several lamps, shielded by coaming and placed close to the indicators to be illuminated, will minimize the glare.

Ultraviolet lighting of fluorescent characters is practical only by spotlighting. Even so, the disadvantages, in addition to glare and the need for a high level source, are many. Fluorescence gives off light of visible wavelengths; some ultraviolet light is reflected into the eyes; dark adaptation is disturbed by the "blueness" of direct ultraviolet light, as well as the invisible portion; and a red fluorescent paint of the proper brightness and wavelength is not now available.

Indirect Lighting. For indirect lighting, lamps with red filters are sometimes placed so that the light shines on a white mat surface and then on to the indicator face. The disadvantages of this system are that it wastes light, much of it being diffused into spaces behind the cover; the brightness across the indicator face is usually uneven; and stray light often reaches the operator's face, in spite of frames, baffles, and louvers.

For edge lighting (transillumination) of panels, red light is passed through a clear plastic face and diffused out through the engraved markings on the outer surface, which has been covered with two coats of paint — a translucent white undercoat sprayed over the engraving, and the top coat an opaque, black paint of low reflectivity rolled on to keep it from filling the engraving. This may be the best method of illuminating dials, but it requires supplementary means of illuminating pointers. A variation of this system can be obtained with "Lamicoid," a three-ply, red-black-white plastic, which appears black with red markings at night, while the engravings appear white against black in daylight. Another variation is the use of raised letters, coated with white, against a black background. The production problem on this system presents difficulties, however, and it is extremely difficult to get even illumination across the face of the indicator. Lettering on the transilluminated

panels must always be of uniform size; optimum letter stroke width is 0.026 inch for day-night vision.

When used with counters, back lighting (Figure 7-19) may be obtained by the use of a beveled window in a plastic panel, which directs reflected light onto the counter disc. This method of lighting transparent discs offers maximum contrast when the markings are engraved in the path of the light. A baffle should be placed around the face to prevent light leaks, which can cause glare.

A new type of panel, the "DaNite," developed by Bendix/9/ is reported to be equally efficient for day or night operation. The numbers and markers are photographed on a panel of clear plastic; in daylight they appear eggshell-white against a dull black background, and appear deep red at night.

Treating with Luminous Paint. Luminous paint is not considered satisfactory for indicator illumination. Its low brightness renders it unsuitable for finely graduated scales; indicator brightness cannot be controlled; and many of the luminous paints are greenish, which causes glare and destroys dark adaptation.

Aural Equipment. The possibilities of aural display for the communication of information are only beginning to be exploited. Aural signals have a distinct advantage in that certain sounds can give meaningful information without prior attention. Aural and visual signals enhance each other; and, perhaps most important, sound can be used as a substitute for visual displays when the visual load on the operator becomes too great.

Interphone Communication. Microphones are available in various designs, all of which, unfortunately, have some disadvantages. Hand-held mikes require the use of one hand and do not exclude ambient noise, unless provided with special shields.

The lip-type, noise-canceling mike frees the hands and is the most satisfactory in low noise levels where acoustical feedback is a critical problem. It is sensitive to wind noise.

Throat mikes have low noise pickup and free the hands, but the speech signal available at the larynx is not intrinsically intelligible.

The enclosure-mounted mike inside an oxygen mask excludes noise and frees the hands, but accentuates the lower frequencies.

Earphones are of two kinds: magnetic and dynamic. The latter is considered somewhat superior, regardless of the type of socket used.

A number of refinements have been developed for the headset. Circumaural sockets provide a comfortable seal between earphones and head, although the large amount of air enclosed puts great demands upon the earphone.

Dual-seal sockets, because of the smaller volume of air enclosed, offer good insulation, but individual fit remains a problem.

Semi-insert tips permit uniform attenuation of ambient sound for all frequencies and are comfortable. Full insert tips provide the greatest insulation against ambient noise and increase the sensitivity of the earphones, but individual fit and the matter of sanitation are serious drawbacks.

Controls. On occasion, operators must respond to one of a group of controls in situations where visual cues are minimized, as under dark-adaptation conditions. Under such conditions, it is extremely important that some effort be made to eliminate error by standardizing controls on the basis of size, shape, color, method of operation, and position.

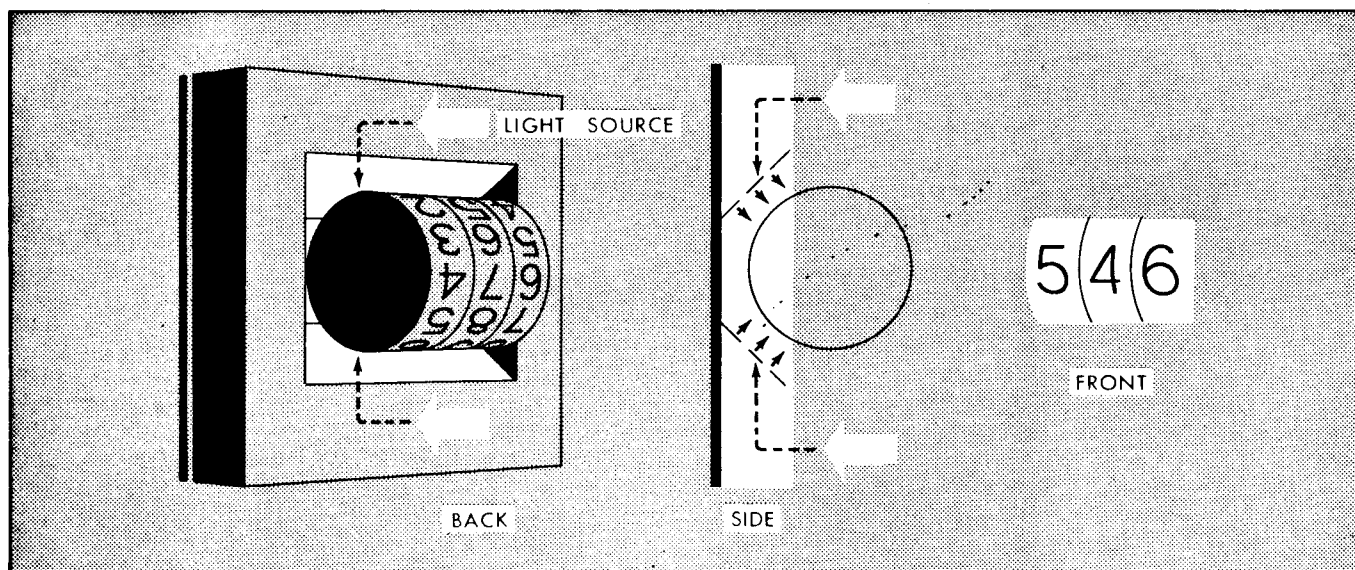

Figure 7-19. Back lighting for counter displays

The U. S. Air Force Air Materiel Command has made various studies of the control problem, and some fairly reliable conclusions have resulted.

The efficiency with which a particular control arrangement can be operated is considered to be dependent on many factors: location of control and indicator, effect of the control, tactual aspects, the speed and accuracy required, and so on.

It has been found that if controls are to be operated efficiently and accurately, they should function in a manner consistent with the operator's expectations or previous experiences. When a control and a display are in the same plane, operators associate a clockwise control motion with a clockwise display motion, and a counterclockwise control motion with a counterclockwise display motion. This tendency is sometimes called the "clockwise-clockwise hypothesis," and when these conditions exist, the likelihood of correct response is increased. The hypothesis assumes that the control and indicator are in the same plane and facing the operator.

Whenever possible, control movements should parallel the axis of the motion they affect. Clockwise, forward, or upward motion should show a related pointer increase. Controls should be designed so that the operator centers deviations or pointer intersections.

Tactual Discrimination. In a study/10/ of tactual discrimination among a series of lever-type aircraft control knobs, the shapes illustrated in Figure 7-20 were found to be correctly and almost immediately recognized by touch alone. Undoubtedly, many of these knob shapes can be adapted to electronic equipment.

Controls should be easy to grasp. Tactual discrimination is best when the controls are separated by about 6 inches. Knobs should be 1 or 2 inches in diameter. Knobs with attached pointers should be mounted so that the pointers are close to the surface of the panel.

OFF-ON Controls. Normally, all OFF-ON controls should be toggle switches accompanied by a pilot light. The switch and light should be located near the upper right-hand corner of the instrument panel, with the switch placed so that the ON position is in the direction of the pilot light.

Mechanically-Aided Finite Setting. Step-functions should be controlled by bar-type knobs. These can vary in length from 1 to 3 inches, but should not protrude more than 1 inch from the panel surface, and no more than 2 pounds of torque should be required to turn the knob to the desired position. Where several of these switches are mounted together, orient them so that the OFF positions are in the same direction. When only two positions are needed, the separation should be 90 degrees; for three positions, a 45-degree separation is best. (See Figure 7-21.)

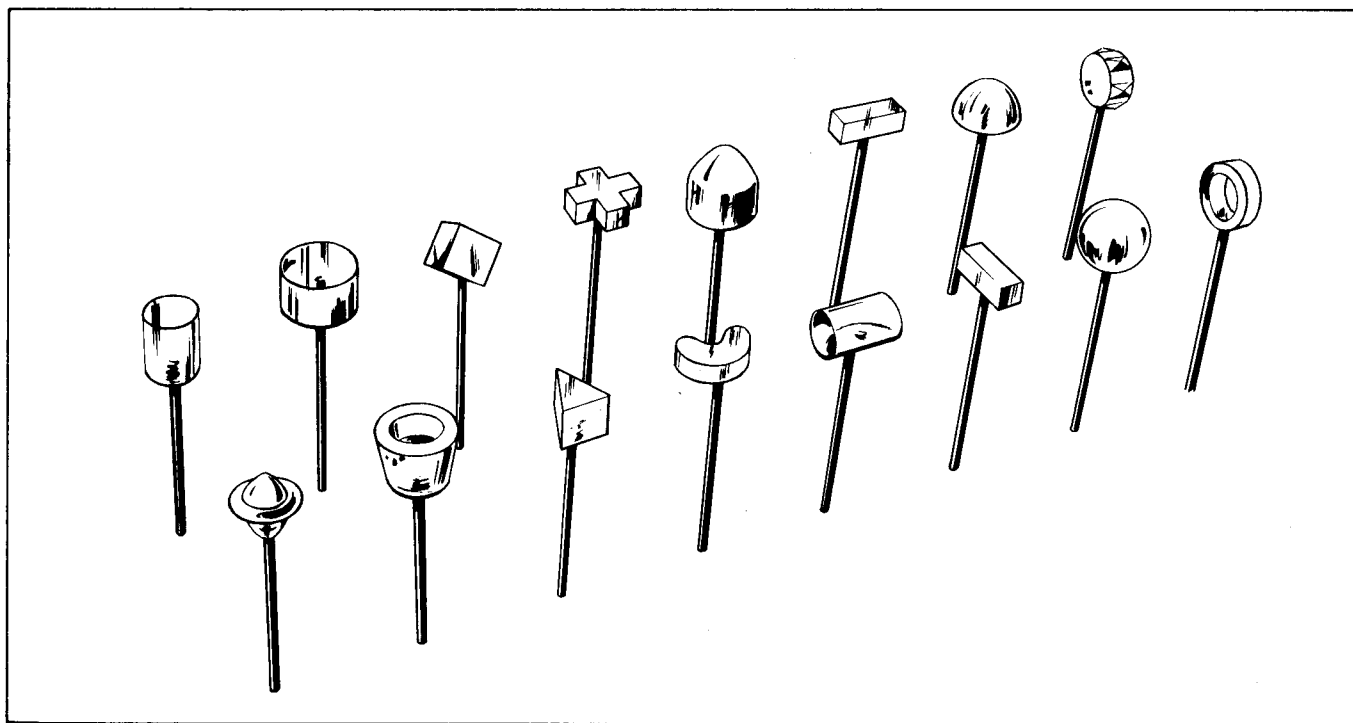

Figure 7-20. Easily recognizable knob shapes

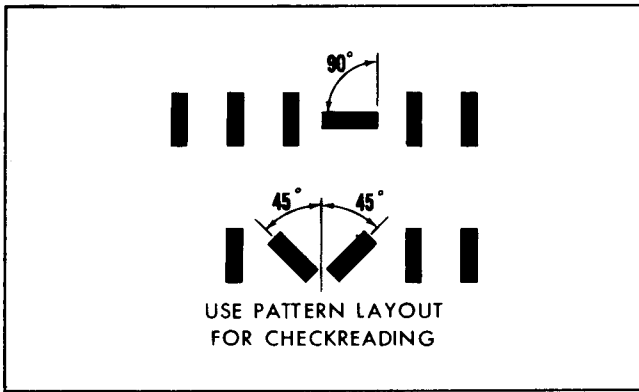

Figure 7-21. Layout for many three-position switches

Three-position, toggle-type switches are good when a spring-back system is needed to return the switch to neutral automatically. The OFF-ON designation should not be used with this type of switch. Normally, this switch is recommended for horizontally oriented panels, since the switch position is more visible in this arrangement.

**Unaided Finite Setting.** This type of setting is mainly for controlling visual or aural displays and is generally continuous. The dimensions for knobs used for setting a visual display are given in Figure 7-22.

Figure 7-23 indicates optimum turning for muscular bracketing to locate a null position, as in tuning a transmitter.

**Continuous Correction Controls.** Controls used in tracking or steering operations are called "error reducing" responses. Handwheels, steering wheels, cranks, joy sticks, rudder controls, and so on are normally suggested for this type of control, although knobs may be used in many cases.

Cranks are recommended for rapid turning (100 to 200 rps). They may vary from 3 to 9 inches in diameter. An inertia of 2 to 5 pounds for smaller cranks and of 5 to 10 pounds for larger cranks is recommended. Friction should be avoided whenever possible, particularly in tracking operations. Direction does not affect the speed of rotation, but the accuracy of following depends on the natural relationships with a visual display.

Handwheels are recommended for turning 0 through 90 degrees where small, accurate changes are necessary, where more strength is required, and where two-hand operation is desirable. Diameters may vary from 10 to 20 inches. The slower the movement required, the larger the diameter should be, and the larger the wheel, the more the torque that should be added. An inertia equivalent to a 20-inch ring weighing about 55 pounds is an example of an optimum condition. The best position for mounting is with the horizontal axis for the wheel perpendicular to the body. The same rules apply for levers and crossbars.

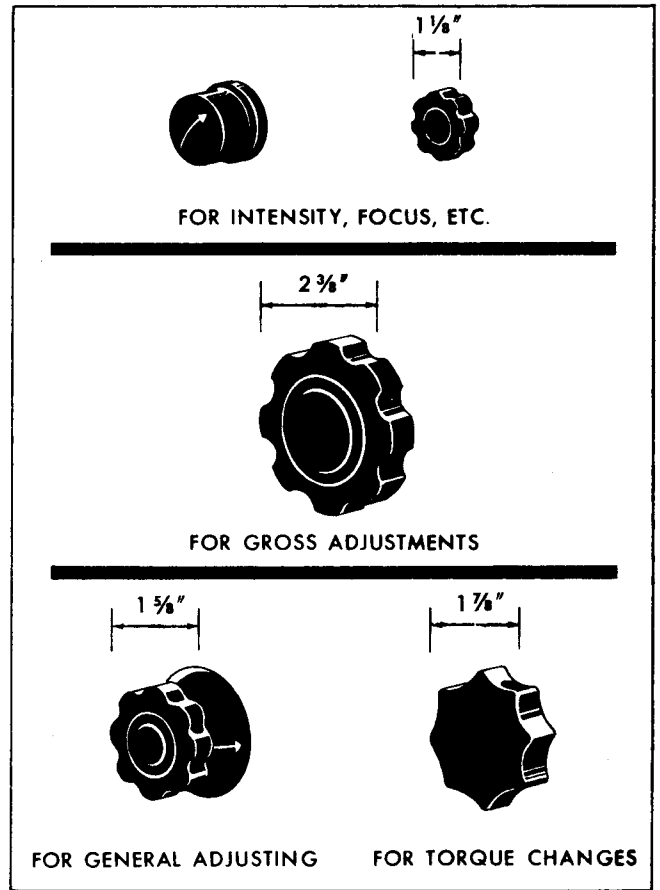

Figure 7-22. Knob types for use with visual displays

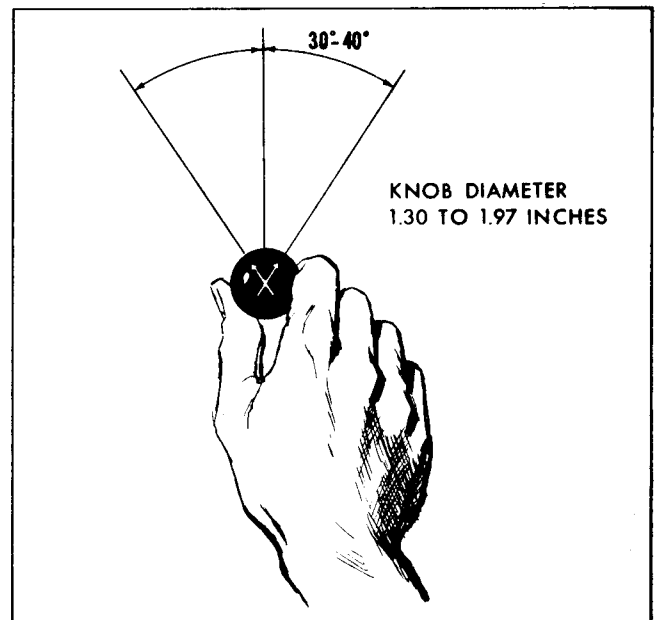

Figure 7-23. Optimum turning for muscular bracketing

Tuning Dials. Divisions and lettering on tuning dials should be suitably etched or printed with characters large enough to be read under normal conditions of eyesight and lighting at a distance of 2 feet anywhere within a solid angle of 60 degrees.

Dials should be marked so that at least 2 calibration numbers on each band can be seen at any dial setting.

Pedals. For pedals requiring up to 20 pounds pressure, placing the fulcrum at the heel requires the least effort and time per stroke. Such pedals can be used to provide continuous or variable pressures.

For simple OFF-ON switching, the spring-loaded, SPST normal-off type pedal is best.

When greater strength is required, pedal action should be designed to include the foot and entire leg as a unit. The greatest strength can be applied when the lower leg is at an angle.

#### APPLICATIONS TO MAINTENANCE ENGINEERING

In applying human-engineering concepts to the design of ground electronic equipment, it is vitally important that the designer keep in mind the capabilities and limitations, not only of the operator, but of the maintenance mechanic as well. Such effort is obviously worthwhile in terms of increased productivity and reliability of the equipment and safety of the maintenance personnel.

Some existing malpractices in equipment design for the maintenance job can be eliminated by the application of human-engineering principles now established; others are not so easy of solution, and considerable study of this particular field is needed.

In approaching this problem, the designer must analyze the equipment to determine what it requires of the mechanic, and also what demands the mechanic makes on the equipment. Together, these two analyses can detect human-engineering problems where they exist, and point to a solution.

In a study of maintenance problems as related to human engineering made by the American Institute for Research, /11/ difficulties in maintenance performance were itemized under the following topics: (1) accessibility, (2) presentation of technical information, (3) test equipment, (4) working conditions, (5) environmental effects, (6) safety, (7) component size, (8) power problems, (9) color coding, (10) warning indicators, (11) cable connectors, (12) panel controls and meters, (13) circuit-switching arrangements, (14) preventive maintenance, (15) trouble shooting, (16) reliability, and (17) supply.

Limitations of space prevent a comprehensive review of the findings and recommendations dealing with these seventeen items, but it is worthwhile to mention briefly some of the major difficulties.

Lack of accessibility was responsible for the most difficulty in keeping the equipment maintained. A few examples of inadequate concern with accessibility were: cover plates held by an inordinate number of screws, vacuum tubes difficult of access and awkward to remove, screwdriver adjustments located in out-of-the-way places, and test points haphazardly placed. Designers should refer to the body measurement data on the minimum space needed for human manipulation, the maximum amount of force that can be exerted by hand, and so on.

The second major source of difficulty concerned the facilities for checking and testing. Equipment was often designed with no outlets on the prime component for checking an important function, check outlets were located in inaccessible places, some test equipment was too bulky or heavy for easy transport to its place of use, and facilities for attaching test equipment were often inadequate.

Another common difficulty was found in the preparation of technical information used by the mechanics. This information should be geared directly to the mechanic's jobs; information should be located easily in the technical orders and should specify clearly what to look for and what to do in lucid, unequivocal terms. The distinction between texts and job instructions should be recognized.

An extremely important human-engineering consideration is that of protecting maintenance men against the hazard of their jobs. Exposure to high voltage and hot electronic parts, for example, can be minimized by shielding the high voltage surfaces, shielding the mechanic, and providing adequate warnings. It is the job of the designer to compensate for such human behavior liabilities as forgetfulness and the contempt of a hazard bred of familiarity.

Warning equipment is often unsatisfactory from the maintenance standpoint. Mechanics work most frequently under conditions of high noise level and low illumination — factors that should determine, in part, the type and intensity of the warning signals used.

Color coding is another item that needs re-evaluation. Coding of wire should be such that the mechanic can discriminate easily between various patterns. In this respect, it is worth noting that a survey /11/ shows that many maintenance personnel feel that wire insulation with solid color stripes would be easier to identify than the patterned type of color coding currently in wide use.

These are only a few of the complications that demand the attention of the designer. He should make an attempt to see the human-engineering problems in maintenance in a fresh perspective, and should not accept unquestioningly either precedence or tradition as solutions for his design problems. The convenient phrase, "This is the way it's always been done," has little validity in a fast-moving technology.



## FURNITURE AND WORK SPACE

**Seating.** Human-engineering principles apply not only to the intricate machinery of modern electronics, but also to the very furniture of the office, trailer, or workshop in which the equipment is to be used. A few of the important items are indicated here. A properly designed seat can reduce fatigue and increase production; improperly designed, it can interfere with the operation of equipment, reduce efficiency, and impair morale.

Specific rules or recommendations are difficult. The design of a seat is determined by its particular use, and should be considered in terms of posture control, convenience to work space, mobility, and adjustability (see Figure 7-24).

For work seating, these general rules and measurements are applicable. The height of an office chair should be about 18 inches, and should be adjustable. Draftsmen's stools should be at least 30 inches high. The seat length can vary from 15 to 18 inches, the width from 15 to 20 inches. For a person using his arms freely, the back should be no more than 15 inches high. Armrests, if used, should be about 8 or 9 inches above the seat and no more than 12 inches long. Seat cushions should slope from front to rear at an angle of about 5 degrees.

Special seating, such as radio or sonar operators' seats, usually require dimension changes to compensate for the occupant's accessory equipment or clothing, ease of adjustments, ease of entrance or egress, and for comfort to relieve the fatigue that results from long use. (See Figure 7-25.) Leather-covered foam rubber padding is comfortable. If the seat is to be raised, a foot rest is necessary to maintain the proper ratio of foot-to-seat height.

**Desks, Counters, Shelves, and Workbenches.** In general, desks, tables, and similar furniture should be at elbow height, with plenty of leg and foot space. Figure 7-26 presents the recommended dimensions for this category of furniture.

Shelves are most useful when their contents can be both seen and reached. Top shelves should be no higher than 70 to 76 inches, and the depth should be determined by considering the unit size — oscilloscopes require deep shelves, smaller portable voltmeters shallow shelves. (See Figure 7-27.)

**Layout of Work Space.** In experimenting with various arrangements for equipment, the designer should keep in mind the functional relationship of the various pieces of equipment, the positions of static and transient personnel, traffic flow, the location of ambient and special lighting, and maintenance. The safety of the personnel is also an important factor. Equipment should be encased wherever possible, safety routes and exits should be planned and marked, and ventilation and air conditioning should be provided where needed.

**Illumination.** Other factors being equal, visibility increases as illumination increases. However,

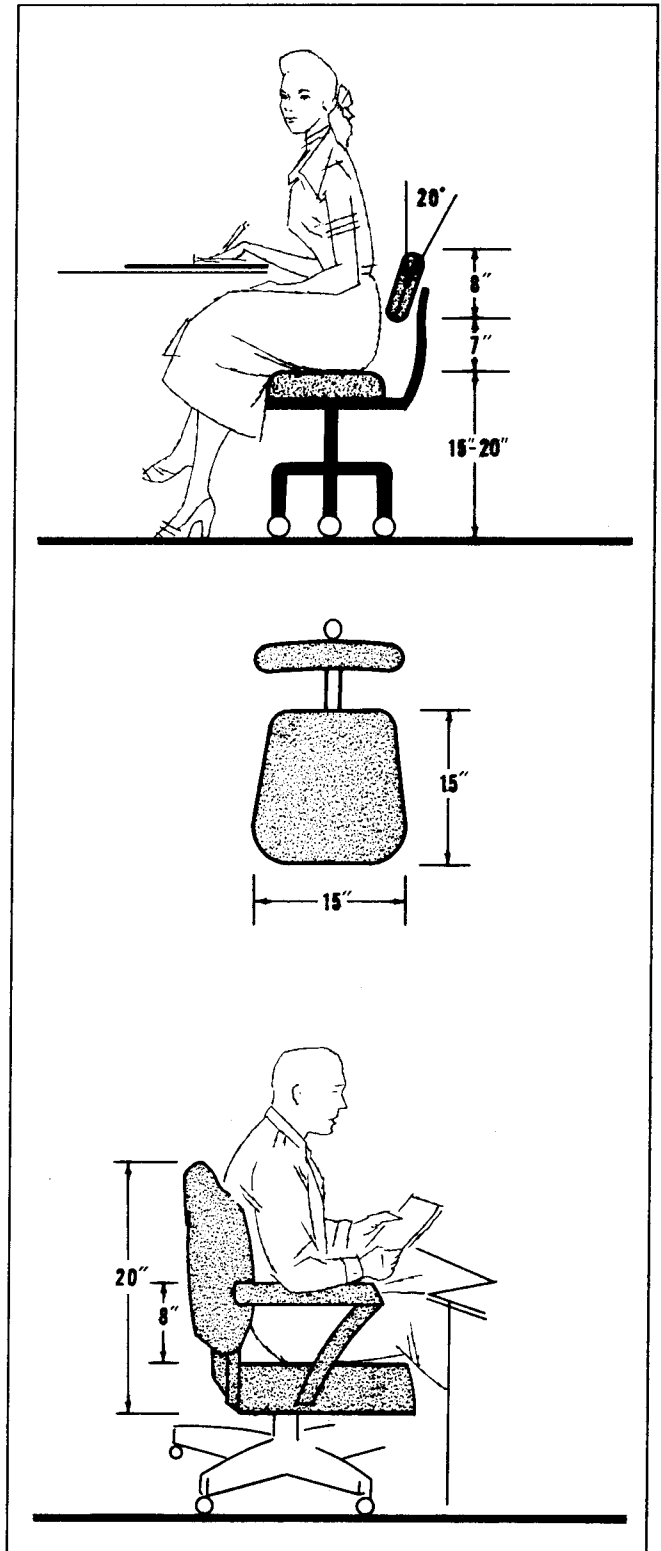

Figure 7-24. Comfortable seating

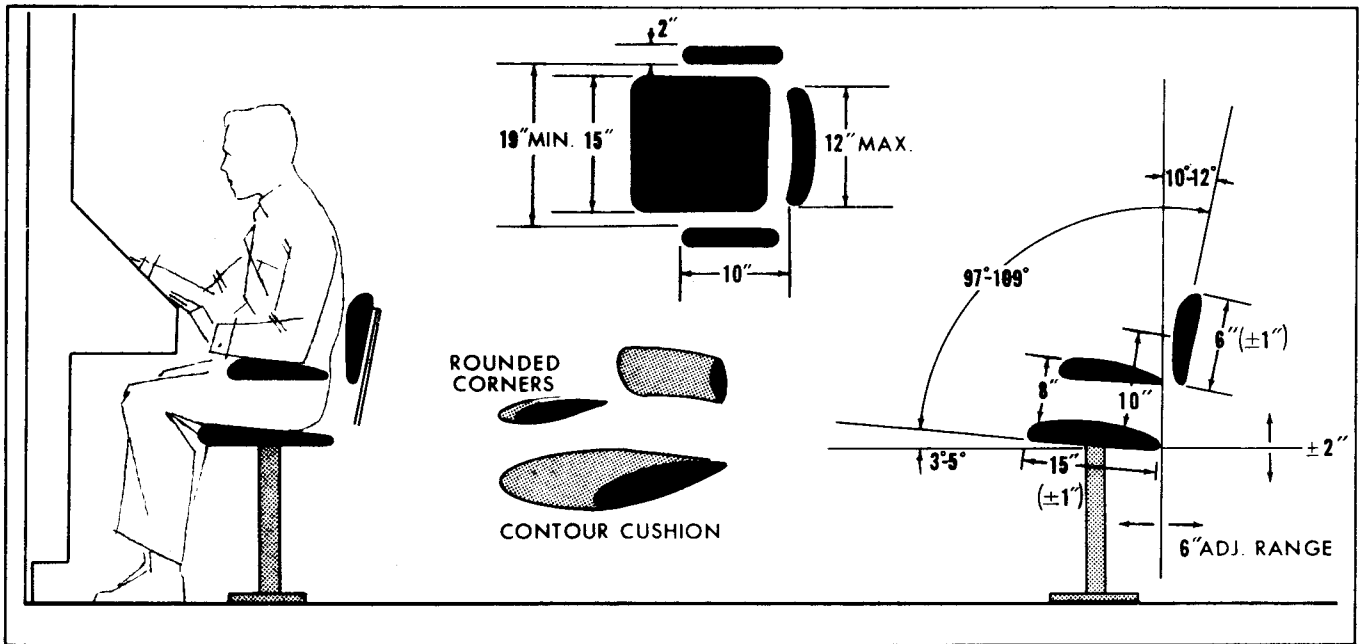

Figure 7-25. Special seating for sonar or radio operators

there are limits for various situations where additional light is of little or no value.

General lighting should be lower than illumination on the specific task at hand, but brightness contrast should be no higher than 10 to 1 for general work, and 3 to 1 for fine detail work.

Dust and dirt will defeat the illumination plan if allowed to remain on light fixtures or reflecting surfaces.

**Natural Lighting.** Natural daylight may be introduced in a number of ways. Unilateral lighting is most desirable from north-facing windows; but whatever the direction, seating should be arranged so that the light is at the left. When bilateral lighting is used, seating should be arranged parallel to the windows. Outriggers (Figure 7-28) can be used to screen out direct sunlight and provide indirect natural light. Reduced window heads will eliminate ceiling shadow. The central glare area of a large window can be eliminated by using two roller shades.

**Artificial Lighting.** Direct lighting provides maximum utilization of light, with 90 to 100 percent of the output directed downward toward the work area. The most prominent faults of direct lighting are undesirable brightness ratios, shadows, and glare.

Indirect lighting eliminates shadows and glare by shielding the source so that between 90 and 100 percent of the light is directed toward the ceiling and upper walls, from which it is reflected more or less evenly about the room.

Diffuse lighting is undirected light scattered evenly in all directions. It requires less wattage than either of the other systems, but it does cause some

glare and shadows. Fluorescent units with baffles are used to solve most of the glare problems of the diffusing enclosure. Direct or indirect light may be combined with diffuse lighting to provide modifications as needed.

Tests have shown that the loss of ocular efficiency, over a 3-hour period of continuous reading, is 10 percent with indirect lighting and 80 percent with direct lighting.

**Glare.** The most harmful effect of illumination is glare. The direct glare zone can be eliminated or mitigated by proper placement of the source and by shielding, and also by rearrangement of desks, tables, and chairs. Overhead illumination should be shielded to about 45 degrees to prevent direct glare. Reflection glare from the work surfaces interferes with vision at a desk or table and requires special placement of light sources. Reflecting areas should be properly surfaced. Mat finishes of a light color are recommended for walls and furniture.

Eyeglasses cause disturbing reflections unless the light sources are 30 degrees or more above the line of sight, 40 degrees or more below, or outside the two 15-degree zones.

**Minimum Levels of Interior Illumination.** Fine detail work requires at least 50 ft-candles, or 8 watts per square foot or floor space. General visual work requires at least 30 ft-candles, or 6 watts per square foot of floor space. Rooms not used for study or close visual work require at least 10 ft-candles, or 4 watts per square foot of floor space. Passageways, restrooms, and storage areas require a minimum of 5 ft-candles, or 2 watts per square foot or floor space.

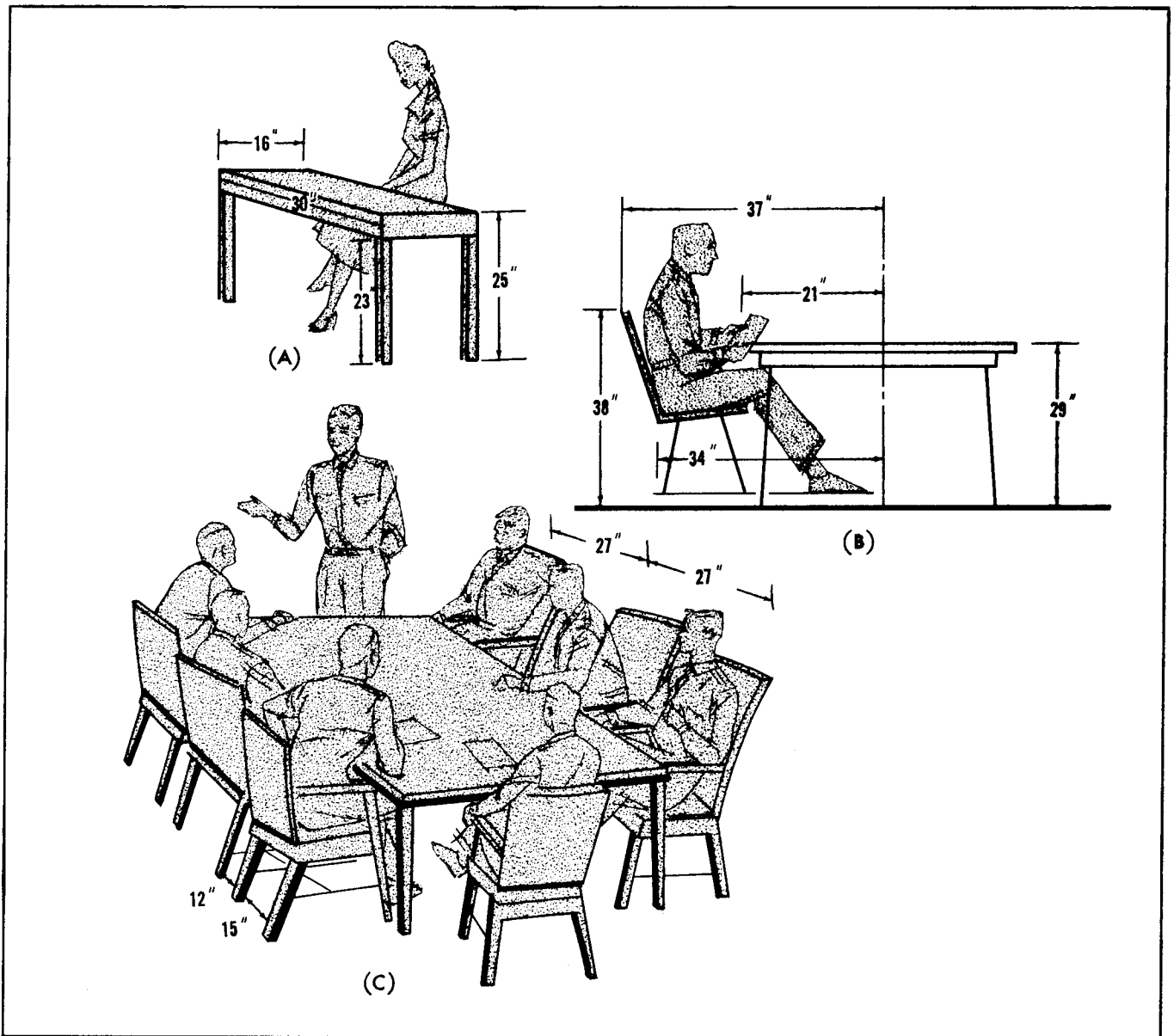

Figure 7-26. Table layouts

**Use of Color.** The color schemes of buildings and equipment should, in general, follow utilitarian rather than esthetic standards, but the psychological factors should be considered along with the physiological.

The physical-affecting features of colors must be considered when planning the exteriors of structures. The color of a metal building or a flat roof will determine the amount of heat absorbed or reflected. Light colors reflect, dark colors absorb. In a warm climate, such structures should be painted white or aluminum.

The hazard of glare should be considered in selecting colors for the lower portions of exteriors, particularly for buildings with wings, from which light walls may reflect blinding sunlight through fac-

ing windows. As a rule, lower exterior walls should be slightly darker than upper walls and roofs.

Illumination is the major consideration in selecting colors for interiors. For ease of seeing and eye comfort, ceiling colors should have high reflectance factors and a mat finish to prevent glare. White, ivory, cream, and buff are satisfactory, having reflectance values of 80 to 100 percent. Upper walls should be light — pale green, buff, gray, blue, and so on — in order not to contrast too much with ceiling or window areas, and should also be of mat finish. Lower walls should be darker than upper walls, but of not too great a contrast. Medium shades of green, brown, gray, and blue are acceptable. Woodwork may either match or contrast with wall colors. If contrasting, it can be painted a uniform white, ivory, cream.

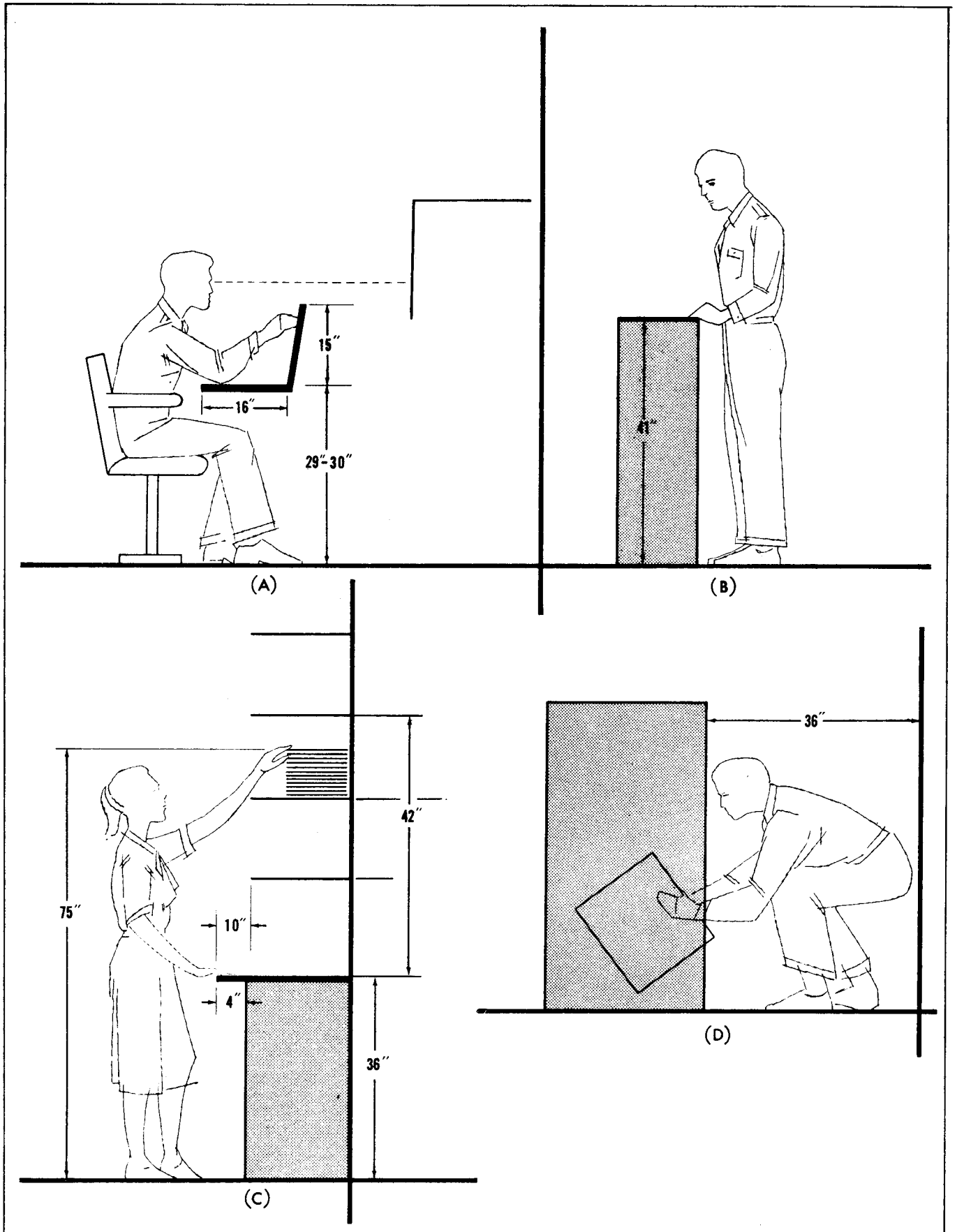

Figure 7-27. Typical work area layouts

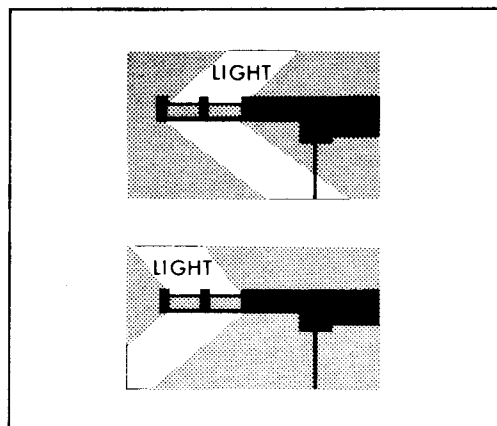

Figure 7-28. Outriggers used to direct sunlight

or light gray. Flooring should have about 15 to 30 percent reflectance, but should not be too dark.

Table 7-5 /12/ gives the reflection factors of typical paint, paper, and wood finishes.

Furniture in work areas should be light in color, with a 30 to 50 percent reflectance factor. Desk surfaces should approximate a mat finish; metal desks with dark tops should be avoided. Chairs can have a gloss finish. Natural wood finishes are satisfactory if not too dark.

For the psychological determinants of a room color — such as restful, calm colors for places of relaxation, stimulating colors for work areas — see the paragraphs on "Vision."

Large expanses of fixed mechanical equipment should be painted in neutral, eye-resting colors, such as gray, with the immediate working area a light buff.

Mobile shop machinery should be bright yellow, with the larger machines slightly darker and with black and yellow bumpers. Yellow has also been adopted for certain maintenance equipment.

Electric controls and outlet-box exteriors should be blue, with the inside of the box orange to

indicate danger. High-voltage locations should be indicated by orange paint.

The indication for first-aid equipment has been standardized as a green cross on a white background.

The National Safety Council has recommended the following color coding:

- RED — fire-protection equipment. (Stand-pipes, hose connections, fire mains, and so on. Fresh-water hydrants should be yellow with red tops.)
- GREEN — safe materials, such as water and brine. (Gray, black, or white are also acceptable for these.)
- BLUE — protective materials, such as antidotes for poison fumes.
- PURPLE— valuable materials; caution against waste.

Noise Problems. There are various ways of reducing noise: by eliminating or isolating the source, by acoustical treatment of the hearer's environment, and by the use of earplugs. Most places, no matter how noisy, can be benefited by reducing the noise level, for even a drop of 3 or 4 db is noticeable.

Bare boards and battens magnify floor impact noises, particularly in long corridors, and the use of woodblock, asphalt, or thick linoleum on concrete is recommended. Doors opposite each other transmit noise freely, while doors staggered along a corridor will reduce the transmission of much unwanted noise.

Windows can be designed to eliminate as much as 53 db of noise. A single pane of 21-ounce glass can reduce noise by 28 db; 1/4-inch plate glass cuts out about 35. Double windows are even better — 21-ounce glass with a 1-inch air space gives a 42-db reduction, and an 8-inch interspace gives a 53-db reduction.

Table 7-5. Reflection factors of paint, paper, and wood

Color	Percent of reflected light	Color	Percent of reflected light
White	85	Dark gray	30
Light cream	75	Dark red	13
Light gray	75	Dark brown	10
Light yellow	75	Dark blue	8
Light buff	70	Dark green	7
Light green	65	Wood finish:	
Light blue	55	maple	42
Medium yellow	65	satinwood	34
Medium buff	63	English oak	17
Medium gray	55	walnut	16
Medium green	52	mahogany	12
Medium blue	35		

Ventilation fans should have a tip speed no faster than 55 feet per minute and an air outlet velocity no greater than 1,500 feet per minute. The fan casing should be rigid or damped, and super-silent motors should be used./13/

Temperature and Ventilation. The effects of temperature upon human performance are still in the exploratory stage, but it has been established that extremes of heat and cold are detrimental to work efficiency. Moderately complex tasks, such as hand coordination or visual attention without physical exertion, are possible in temperatures as high as 30 C, but as the complexity of the task increases, or with the addition of physical or mental strain, this maximum is lowered slightly.

A temperature of 50 C is tolerable for about an hour (70 C for a half hour), although this is far above physical or mental activity range. Mental deterioration begins at 30 C, physical deterioration at 25 C. The optimum temperature is about 20 C.

Humidities between 30 and 70 percent seem to be comfortable for most people.

When the air temperature drops below 15 C, the body begins to cool; heat is lost mainly by convection and radiation, somewhat by evaporation. Above 36 C, the body gains heat by convection and radiation in greater quantities than it can cool itself by these means, so that heat dissipation must be accomplished by evaporation. Individuals can adapt to changes up to 20 percent in any of these factors in the comfortable temperature range and up to 35 percent in conditions of extreme cold, but not necessarily in conditions of extreme heat.

The normal breathing rate of an adult is between 12 and 20 respirations per minute. Taking an average of 16 respirations per minute, the air required for normal breathing would be about 8 liters (0.28 cubic feet) per minute. At sea level, the oxygen content of the air is about 21 percent, and about 12 percent at 15,000 feet. The CO<sub>2</sub> content in an enclosed air space occupied by personnel should not be greater than 0.5 percent. Between 1 and 2 percent concentration in inspired air is not noticeable, although it may reduce efficiency. When more than 3 percent CO<sub>2</sub> is present, a person will notice slight effort in breathing; when between 5 and 10 percent is present, a person will breathe heavily and tire quickly. More than 10 percent CO<sub>2</sub>, if present for any length of time, will be fatal.

Oxygen consumption per person at sea level in cu ft per min	Ventilation rate per person in cu ft per min to maintain concentration of CO <sub>2</sub> below 0.5 percent			
	Sea level	5,000 ft	10,000 ft	15,000 ft
0.008	1.2	1.4	1.7	2.1
0.028	3.9	4.7	6.7	6.9
0.056	8.7	9.7	11.7	14.5

## REFERENCES

1. Human Engineering Guide for Equipment Designers, U. S. Navy Electronics Laboratory, San Diego, Calif., NE 121303, Problem NEL 3 B1a, 15 February 1951.
2. Fletcher and Munson, "Relation Between Sound and Masking," Journal of the Acoustical Society of America, Vol. 9, 1937, pp. 1-10.
3. Frescoln, L. D., "Range of Bodily Movements," Medical Times, Vol. 57, 1929, pp. 197-198.
4. Barnes, R. M., Motion and Time Study, Wiley, 1949, p. 144; also Hartson, L. D., "Contrasting Approaches to the Analysis of Skilled Movements," Journal of General Psychology, Vol. 20, 1939, pp. 265, 268, 269.
5. Handbook of Human Engineering Data for Design Engineers, Tufts College Institute of Applied Experimental Psychology, Technical Report No. SDC 199-1-2, NavExos P-643, 1951.
6. Meredith, Florence L., Hygiene, Blakiston Co., Philadelphia.
7. Continental Air Defense System, Final Report, prepared by Bell Telephone Laboratories, Inc., for Air Defense Command, U. S. Air Force, 30 January 1954.
8. Standards To Be Employed in Research on Visual Displays, Armed Forces-National Research Council Vision Committee, May 1, 1950.

9. Sitton, J. M., "Pilots See Red for Better Night Vision," Aero Digest, Vol. 58, No. 6, June 1949, pp. 48-49, 112.
10. Investigation of Shapes for Use in Coding Aircraft Control Knobs, Air Materiel Command, Wright-Patterson Air Force Base, 19 August 1946.
11. Survey of Human Engineering Needs in Maintenance of Ground Electronic Equipment, American Institute for Research, February 1954.
12. Recommended Practices of Home Lighting, Illuminating Engineering Society, 1947.
13. Bagenal, H., Practical Acoustics and Planning Against Noise, Chemical Publishing Co., 1942.

#### BIBLIOGRAPHY

Handbook of Human Engineering Data for Design Engineers, Tufts College Institute of Applied Experimental Psychology, Technical Report No. SDC 199-1-2, NavExos P-643, 1951.

Sheldon, W. H., et al, The Variety of Human Physiques, Harper and Brothers, New York, 1940.

# CONTENTS

## chapter eight **component parts**

General Problems

Tubes Specifications

Proper and Improper Ways to Use Tubes

Fixed Resistors

Capacitors

Connectors

Transformers, R-F Coils, and Inductors

Relays

Vibrator Selection and Usage

Synchros and Servos



# COMPONENT PARTS

The role played by component parts, including tubes, in the general unreliability of military equipment was made clear by studies first undertaken in 1950. The truth is that many component parts failed in service. But one must consider the very high population of military apparatus in service and multiply this figure by the average number of component parts per equipment to gage the real situation.

In the year 1950, the Navy had an estimated equipment population of 165,000, comprising some 2,600 models. The 50 types of component parts studied by Vitro /1/ covered 23,503 stock numbers and a total parts population of over 20 million, not including tubes. Since about one million failures occurred in the component parts of these equipments, the annual failure rate is about 5 percent. This amounts to approximately 6 to 8 failures per equipment per year, which on the surface may not seem unreasonable at all.

The fact is, however, that one million parts failures per year puts a tremendous burden on Navy maintenance, ties up many men in essentially unproductive and uninspiring repair and maintenance work, and, in addition, is an indication of the amount of time that the various equipments were out of service or functioning poorly. The other Services probably had equivalent failure rates.

Unfortunately, the failure reports studied by Vitro did not give a very clear picture as to the reason for the individual component parts failure, but by now, it is recognized that failures are due to:

1. Misapplication
2. Wrong environment
3. Poor component parts.

That is, the parts were employed in circuits for which they were not adapted — they were selected wrongly; they were employed in circuits that overloaded them or subjected them to conditions, perhaps unrecognized by the designers, under which they

simply could not stand up; they were subjected to temperatures, vibration, humidity, or other physical conditions in which they could not live out their allotted life; or they were poorly made for the job they were supposed to do.

Navy-Bell Laboratories Component Reliability Program. Although the Vitro study gave considerable indication of the causes of component part failure, a further study was contracted to the Bell Laboratories (Western Electric Company)/2/ 1 July 1951 "to provide engineering and consulting services directed toward improving the reliability of circuit parts used in military electronic equipment." This contract terminated 30 June 1953. Although statistically its study of failed components agreed in general with the Vitro figures, certain differences were inevitable, because of the difference in the two programs and the later time period in which the program was in operation.

The Bell study went much further than collecting failure data. Components were returned to the Laboratories from the units from which they had removed and much effort went into attempts to discover why the component parts failed. During the period, 1763 failed components were examined (excluding tubes), some of which came from the Air Force, some from the Signal Corps, but the great bulk of which came from Navy equipment.

Failures of the 1,763 parts were caused by the following reasons.

<u>Cause</u>	<u>Percent</u>
Manufacturing defects	28
Design deficiencies	26
Operating conditions	31
Undetermined causes	15

Thus it was demonstrated that 54 percent of the troubles could be imputed to poor design and manufacturing, a very great deal of which could have

been prevented by better inspection and control in the component manufacturer's plant, plus better inspection in the plant where the components were assembled into equipments.

Design for reliable components, however, must start with better knowledge of what the components are supposed to do, plus better knowledge of the treatment the components are likely to receive in service. With such knowledge, better specifications and tests can be devised. After these steps have been completed, rigid inspection, either by a sampling or on a total inspection basis, will prevent faulty components from getting into equipment.

Failure Rates in Nonmilitary Equipments. Some idea of what can be expected from components and equipments under somewhat better conditions than exist in military establishments can be learned from data cited by Dennis Taylor /3/ for two nuclear energy laboratories. (Refer to Tables 8-1 and 8-2.)

Design Priorities. Telecommunications Research Establishment (TRE) in England, as a result of much field and laboratory experience, has proposed that the order of priority in design of equipment for worldwide use should be the following:

1. Adequate performance
2. Reliability
3. Capability of operation under worldwide conditions
4. Ease of servicing and maintenance
5. Light weight
6. Simplicity of controls
7. Adequate packaging.

All of these factors, except the last, are involved in the proper selection and use of component parts. Statistical analysis of equipment failures under a TRE environmental test indicated that 60 percent of the component parts failures were due to the poor manufacture or the use of unsuitable materials, 35 percent were due to bad design or faulty application, such as electrical or thermal overloading, and about 5 percent of the faults were fundamental, requiring research to establish the cause. And of the total failures in these environmental tests, 80 percent were due to humidity, heat, and fungi, and about 20 percent were caused by shock and vibration.

Component Parts Failures. The Rand report /4/ summary states that:

1. Probably one-third to one-half of the failures of electronic equipment are caused by component part defects.
2. Of the failures due to component parts, about one-half are caused by faulty parts and the other half to improper application and use.
3. In comparison to tubes and other causes of equipment failures, component part failures impose the most serious drain on available maintenance capacity.
4. The major cause of component part unreliability is instability and deterioration of performance; the secondary cause is mechanical damage.
5. Component parts causing the most equipment failures are resistors, capacitors, and connectors. These parts comprise two-thirds of the component parts population and are responsible for more than one-half the parts failures.

Table 8-1

Failure rate for nucleonics instruments /3/

21-month service, 1 January 1950 to 30 September 1951

(Oak Ridge National Laboratory, from data by C. J. Borkowski)

Instrument	Number in service	Instrument failures	Tubes	Capacitors	Resistors	Transformers	Months service per instrument per failure
Scalers	277	1,210	1,642	259	120	62	4.8
Amplifiers	20	67	158	13	32	4	6.3
Rate meters	37	115	300	22	18	15	6.7
Health monitors	232	998	1,163	154	43	39	4.9
Electrometers	51	163	109	12	12	1	6.6
<b>Totals</b>	<b>617</b>	<b>2,553</b>	<b>3,372</b>	<b>460</b>	<b>225</b>	<b>121</b>	

Table 8-2

Annual failure rates for selected nucleonics instruments, 1953/3/

(Atomic Energy Research Establishments, England)

Components	Totals in use	Failures	Percentage failures
<b>Tubes</b>			
Rectifiers	3,858	350	9.1
Double diodes	7,511	125	1.66
Double triodes	9,077	618	6.8
Pentodes	15,413	413	2.67
Stabilizers	3,371	141	4.18
<b>Resistors (fixed)</b>			
High stability	66,929	484	0.73
Carbon G. H.	127,984	323	0.25
Wire-wound	34,676	105	0.30
Potentiometers, Carbon	4,170	10	0.24
Potentiometers, Wire-wound	13,184	28	0.21
<b>Capacitors</b>			
Paper	34,981	77	0.22
Visconol	693	2	0.29
Nitrogol	4,000	6	0.15
Mica	12,533	23	0.18
Ceramic	17,640	26	0.15
Electrolytic	7,471	71	0.95
<b>Inductors</b>			
Transformers	4,440	91	2.06
Chokes	4,835	8	0.17
<b>Miscellaneous</b>			
Relays, G. P. O.	5,181	15	0.29
Relays, High speed	1,767	15	0.85
Meters	1,870	24	1.28
Call registers	618	39	6.32
Selenium rectifiers	3,465	21	0.61

6. The more commonly used component parts tend to be more reliable. That is, a relatively small number of parts used in large quantities tend to have low failure rates, and, conversely, a large number of component types used quite infrequently tend to have relatively high failure rates. Each group accounts for roughly one-half of the total component part failures.
7. Component parts used only rarely and in small numbers give rise to serious problems in production, supply, and maintenance.

components account for only about one-half of the reliability problem. "There are still large areas in systems and management such as proper selection, application, inspection, maintenance, handling, and storage where improvement must be brought about." /5/

The remainder of this chapter will be taken up with suggestions for better selection and usage of component parts of the types that have had the highest failure rates. The material has been gathered from the literature, plus new material contributed by individuals and manufacturing personnel.

#### TUBES

Since tubes still remain the chief cause of equipment down-time because of component part failures, they will be considered first. \*

Noncomponent Causes for Unreliability. In fairness to the components employed in military equipment, it must be realized that there are other reasons equipments fail. In fact, tubes and other

\*The bulk of this material was prepared by A. L. Wilson and N. B. Ritchey, Sylvania Electric Products Co., Kew Gardens, N. Y.

The ARINC study already noted and documented in the first general report showed that, up to March 1953, 489,049 sockets had been under surveillance and that the total number of tubes returned from 18 September 1951 to 1 April 1953 was 45,013. The percentages of removed tubes in each of four defect categories are reported as follows:

No defects	31.8
Electrical defects	28.7
Mechanical defects	21.0
Miscellaneous	18.5

Thus, the largest group had no discernible defects. Two-thirds of the tubes removed, however, were defective. These figures give no clue to the failure rate or the percentage of all component parts failures attributable to tubes. It is known that this percentage is high — tubes account for most of the failures. Estimates as high as 90 percent have been published; other figures are as low as 60 percent.

Whether the responsibility for two-thirds (or more or less) of equipment failures belongs to tubes is in itself not of paramount importance. The important fact is that the tubes account for a considerable part of these failures and are generally regarded as the largest contributor. The frequency with which tubes fail can be reduced by concerted action by the tube manufacturers, the equipment designers, the operators, and the maintenance personnel. Each of these groups must do a job of the highest order, since inadequate performances by any one of them will reduce reliability.

The tube manufacturer's job is primarily producing tubes that are not subject to early sudden failure and that are uniform. That is, the tubes should not experience open circuits or shorts between elements in early life, if used over a reasonable range of operating conditions. Individual tubes of a given type should be as much alike in mechanical and electrical characteristics as possible, and better in this respect than they are at present. Uniformity also implies that tubes change very little from their initial characteristics during rated life. Improvement and adequate control over these two broad factors would do more to increase reliability than such improvements as increased electrical output or increased mechanical ruggedness.

The equipment designer's responsibility is producing satisfactory equipment with the tubes and component parts that represent the best in the present state of the art. At the moment, this means using conservative operating conditions, plus familiarity with the inherent tube detriments (which may or may not be controlled by the manufacturer's testing specification), so that intelligent ways and means can be devised for designing around these characteristics. It is expected that the most important future contributions to reliability will come from the equipment designer.

Maintenance personnel must have a high degree of training to enable them to find and correct a fault in the least possible down-time. It is imperative

that they have a questioning attitude. When a tube goes bad, they should ask why. What caused it? Is the tube actually at fault, or is this a secondary manifestation of a more basic fault? Just getting the equipment working again without tracking down a basic trouble almost guarantees additional failures in the future.

#### THE TUBE MANUFACTURER'S PROBLEMS

A certain amount of insight into the problems of the tube designer and tube manufacturer will aid the equipment designer — especially the young and less experienced engineer — in understanding tubes themselves and, while such knowledge may not help directly in achieving more reliable equipment designs, it may result in promoting more conservative tube usage — which is a worthwhile end in itself.

The designer of reliable electron tubes works with a number of limitations imposed, some of which have opposite effects on the end product; his best solution, therefore, may be the result of a number of compromises. For instance, he usually has to design a tube for a specified bulb size. This can restrict the amount of total power dissipated, because certain bulb temperatures should not be exceeded. Bulb temperature also indirectly determines the maximum ratings for the tube. When high performance is demanded in the form of high-transconductance or high-frequency operation, very close spacings, low interelectrode capacitance, and fine grid laterals are required. Consequently, the maximum interelectrode potentials are reduced, and some ruggedness may be lost, but not necessarily. Exceeding the maximum ratings of a tube during operation can assure reduced reliability.

The conventional structure used in electron tubes has evolved over many years, and modifications of the same basic form are used to make u-h-f pentodes and oscillators, amplifiers, audio power output tubes, and special purpose tubes. The limitations of this structure are sometimes a restriction. The structure requires numerous parts, some of which are quite small. One aspect of reliable tube design is the reduction in the number of parts used and the number of welds necessary, thereby decreasing the number of items that might fail.

Just as a reduction in the number of parts will improve tube reliability, so will a reduction in a tube's mechanical and electrical requirements. Conservative (less than maximum) electrical performance and fewer different applications permit simplified, more rugged structures. Dual types, for instance, are less reliable than single types, because they have essentially two tube structures in one bulb, with the probability of failure at least doubled. Comparable reliability is more difficult to attain with dual types.

The parts used in tube structures are fragile, and processing temperatures to which they are subjected are as high as 1,000 C. In normal operation it is not unusual for a plate to operate in the neighborhood of 500 C and the cathodes at 900 C. Such conditions of manufacture and use result in problems

in maintaining spacings and strength. Quite often, the manufacturer of the material from which the parts are made cannot supply data about the relationship between the material's characteristics and high temperatures. The materials must, therefore, be studied and tested. These investigations may represent a sizable part of the total work done in a reliable tube development program.

It may astonish the equipment designer to know that it was not generally agreed upon until the last few years that the basic mechanism of cathode emission is the migration of free electrons through the cathode coating and into space. This theory is not yet completely developed, nor is the mechanism fully explained. Not until a complete and accepted emission mechanism is available can a tube manufacturer hope to control electron tube emission between lots in production over long periods of time and between tubes in a single production run.

Reliability Programs for Tubes. For years, tube manufacturers have endeavored to improve the reliability of electron tubes. As the frequency of sudden failure was reduced, the effort for improvement became one of altering designs and increasing production controls so that the effect of inherent variations in both electrical and mechanical characteristics was also reduced. For the most part, the variations have been minimized rather than eliminated. Today, reliable-type tubes are simpler and are made to designs known to be more dependable. It is common practice in production lines to emphasize great cleanliness and more thorough inspection of parts and finished tubes, and to exercise maximum control of processes. Thereafter, the testing is complete and rigorous.

Concurrent with this increased tube reliability phase on the part of tube manufacturers, applications were tending toward more complex equipments and circuitry. This trend necessitated much greater outputs from tubes and fewer failures. Studies of these equipment failure patterns showed that the improvement needed in tube reliability was greater than that being attained. The studies also uncovered a number of instances where circuit performance relied on tube characteristics not considered to be important and, therefore, not controlled by the tube manufacturers. In addition, a common practice was operating tubes beyond their ratings, thus increasing the statistical probabilities of failure. Some, but certainly not all, of the misuse of tubes in applications has been corrected, and the misuse in future designs undoubtedly will be decreased.

One result of equipment failure studies has been the increase in the number of tests the tube manufacturer must meet, coupled with tighter limits. The philosophy of controlling the final characteristics of reliable-type tubes will probably continue along this approach, but it is still not fully developed. New controls now reaching the specification stage include the average or mean of a production lot, the amount of spread of particular characteristics, vibration tests using a continuously swept frequency range, and life testing at absolute maximum conditions.

It is estimated that the improvement in tube reliability that has already been attained is of the order of twenty-five times when compared to early World War II types. This has not been enough to keep pace with the increased complexity of the equipment. Without considering environmental effects, it has been stated that increased equipment complexity alone, because of the larger quantities of sockets, requires tubes that are 600 times more reliable. It is not known whether such an improvement is possible; but meanwhile, tube improvements are continuing, and designers are learning more about tubes, thus applying them more intelligently.

In the following paragraphs will be found a discussion of present tube specifications and an explanation of what some of the specifications items mean insofar as the equipment designer is concerned.

## SPECIFICATIONS

Information on tube characteristics useful to the designer and user is contained in a number of places. These sources are the inspection specifications and tube handbooks issued by various agencies and manufacturers. The data are intended for different purposes, and complete information on specific types usually must be collected from these various sources. However, a few available reliable-tube brochures have attempted to bring this information together in one place.

Information Sources. The specification probably most referred to is MIL-E-1B, which has superseded the JAN specifications. When a tube type is to be used in equipment by more than one Service, a MIL-E-1B testing specification is issued. It becomes the military acceptance specification and lists all the tests the tubes must pass to be accepted by the Services. Because it is this kind of specification, only characteristic limits are given for most tube types, and there is no information about center values. MIL-E-1B does show the limit values of various tube characteristics the designer can expect to encounter. This is valuable data but is not adequate.

The newer MIL-E-1B specifications include information on center values and spreads of characteristics as a result of requirements to control these values for certain tests. Expectations are that more of this kind of data will be included, and better information about expected variations will become available.

In some cases, particularly with newly developed tubes, only one of the Armed Forces is interested in a given type. These are not included in MIL-E-1B, and the interested Service puts out a testing specification for its own use. In form and other requirements, however, it is like the MIL-E-1B.

The Armed Services also issue a preferred list of electron tubes, now MIL-STD-200A. This is a list of reliable-type tubes acceptable for use in military equipment, and it is mandatory that tubes for use in new equipments be selected from this list. The intent is to reduce the Service problems of

procurement and storage. A manual entitled Technical Data for Armed Services Preferred List of Electron Tubes is issued by the Armed Services Electron Tube Committee. This manual contains ratings, typical operating conditions, and characteristic curves for the circuit designers' use.

The Joint Electron Tube Engineering Council (JETEC) is an industrial group. Through the work of its engineering committees, it recommends industry standards and tube data. These standards are then jointly or singly approved and issued by the two parent organizations, the Radio-Electronic-Television Manufacturers Association (RETMA) and the National Electrical Manufacturers Association (NEMA). JETEC assigns the type number to new tubes and issues data showing tube ratings and typical operation, and sometimes issues characteristic curves. The purpose of this information is to avoid having more than one type number for tubes of the same design, to assure interchangeability of tubes with the same type number, and to provide information so that the circuit designer can select the proper tube for a specific application.

This information comes from the manufacturer and usually includes only center or bogey values. There are some instances where testing limits are given in the same form as MIL-E-1B, but they are not very numerous. Neither does the data necessarily include all the tests made on the tubes prior to shipment. Consequently, the designer will find more information on characteristic curves in JETEC but more about individual tube limits in MIL-E-1B.

Much design information is contained in the manufacturers' brochures and handbooks. These have been prepared with the purpose of filling the designer's need for more diverse and accurate data for reliable equipment design. Here can be found recommendations on circuit design, mounting techniques, operating conditions, bogey values, and testing limits. Not every question the designer may ask will be answered here, but many of them will be. Variations in tubes at other than rated conditions, for example, are usually not covered. Acquisition of these brochures will supply the designer with information directly applicable to his problems.

Testing Specifications. A comparison of one of the more recent reliable tube testing specifications with World War II JAN test specifications will disclose numerous differences. First is the number of pages in the reliable type specification and the number of tests made. The increase in tests is about two to one. This is a reflection of increased control over more characteristics and the requirement that the tube be satisfactory for wider applications. The number of explanatory notes also has increased.

The mechanical ruggedness tests now required usually include a vibration noise test, a fatigue vibration test, a shock test, a glass thermal shock test, sometimes a lead bend and lead pull test, and, occasionally, a vibration life test. Mechanical ruggedness is thereby given more importance than before, as a result of awareness that the use to which tubes are subjected increases tube failure manifold.

Life tests now made differ a great deal from older requirements. The old specifications required a 500-hour test on 10 tubes at rated conditions and room temperature. Only one characteristic had to remain above some minimum value through 500 hours. Using this value as a criterion for failure, the mean life of the tubes could be as low as 400 hours. Present tests require that many more tubes to be tested. They are run at room temperature for the first 100 hours; then 20 tubes usually are continued to 500 hours at high temperature. The voltages applied to reliable tubes are turned on and off a prescribed number of times per hour and lifetime is the total time the voltages are applied and currents are drawn. At present, the voltages are rated voltages, but future specifications will require absolute maximum conditions. There are controls on the amount of initial variation of certain important characteristics, and sometimes eight characteristics must remain within limits to 500 hours. Not more than a specific number of tubes in the sample may fail for a given test, nor more than a specified number for certain combinations of tests. This life test is continued at high temperature to 1,000 hours and a room temperature test is run to 5,000 hours for information purposes.

The life specification requires that the initial stability of the tubes be better, and that more characteristics remain uniform throughout the life test. There must be fewer failures under much more severe operation. The effect of temperature alone is to increase failure rate by an estimated five times.

The relative amount of allowable spread in characteristics, as evidenced by the differences between minimum and maximum limits, is less for the reliable tubes. For example, the 1948 JAN specification for the 6AK5 had limits of  $\pm 60$  percent for plate current and  $\pm 30$  percent for transconductance, but the 1953 specification for the 5654/6AK5W/6096 has limits of  $\pm 37.5$  percent and  $\pm 22.0$  percent for the same characteristics. This tightening of limits is true of the other characteristics and reflects the uniformity accomplished by better design and increased control of manufacturing. The newcomer to the electronics field may be appalled at the size of these spreads, even for the "reliable" tubes, if he is accustomed to tolerances of parts and products of the order of a few percent and less. Tube spreads are wide, even though dimensions of all tube parts are held to low tolerances. The amount of electrical characteristic variation that is typical in tubes results from the cumulative effects of small between-element spacings that are difficult to control to low percentage variations and to nonlinear electrical laws.

MIL-E-1B. Testing specifications in MIL-E-1B are complex and require explanation if one is expected to understand all that MIL-E-1B says and implies. Here, unfortunately, experience is not the best teacher, because interpretations by the uninformed can often be wrong and continue uncorrected. In addition to the testing specification, there are other pertinent publications that must be used with a MIL-E-1B testing specification that the designer would probably not see. These are the basic MIL-E-1B, Inspection Instructions for Electron Tubes, and MIL-

STD-105A. Reference to these publications provides descriptions of how the tests are to be made, the test equipment parameters to be used, physical dimension limits of the tubes, and the degree to which the tubes must meet the testing limits. Attempts to explain the testing specification have been made elsewhere, but it is hoped the following will add to what has been said.

A receiving tube rating, as defined by JETEC, is a designation of an operating limit of a tube. Each maximum rating must be so considered in relation to all other maximum ratings that no one maximum rating will be exceeded in utilizing another maximum rating.

The ratings at the top of the sheet of a MIL-E-1B or in a JETEC testing specification are absolute maximum values. They are limiting values beyond which the serviceability of the tube may be impaired from the viewpoint of life and satisfactory performance. Therefore, in order not to exceed these absolute ratings, the equipment designer has the responsibility of determining an average design value for each rating such that the absolute values will never be exceeded under any usual condition of supply voltage variation, equipment component variation, load variation, or condition due to a normal variation of tube characteristics.

Predetermined average design values are seldom specified in MIL-E-1B, but are given when necessary, and are referred to as design-center ratings. They are established to provide satisfactory performance in the greatest number of equipments. These ratings are maximum values at which equipment may be designed to operate for a bogey or average tube at normal line voltage. With normal line-voltage variations of  $\pm 10$  percent, with normal equipment variations, and with the normal variations in tube characteristics, the average serviceability of the tube will not be impaired. The design-center system also places the responsibility on the tube manufacturer to rate each tube so that values in excess of the design-center rated values due to normal line-voltage variation of  $\pm 10$  percent and due to normal variations in tube characteristics will not, on the average, affect the serviceability of the tube.

In the MIL-E-1B specifications using the absolute maximum system, the characteristics usually assigned maximum values are electrode potentials, heater-voltage variation, electrode dissipation, current levels, altitude, bulb temperature, and mechanical shock level. MIL-E-1B also states that combinations of absolute maximum ratings cannot necessarily be obtained simultaneously. In fact, it is safe to say that for the major portion of tube types, all of the absolute maximum ratings cannot be obtained simultaneously.

The test conditions shown near the top of the tube testing specification (TSS) but below the absolute maximum and minimum ratings are the voltages applied to the various electrodes and the circuit components to be used in making the various tests listed on the TSS. These will apply for each test, unless

they are superseded by other requirements shown with the test.

In almost all the tests, the conditions are more or less arbitrary. From the general requirements at the top of the TSS to the specific conditions of a particular test, a particular set of voltages, currents, dissipations, and so on, defines one of an infinite number of possible operating conditions. These are set by the manufacturer and represent only a point of control at which tubes can be classified as satisfactory or unsatisfactory. These conditions cannot cover the multitude of possible combinations that may be found in applications. They represent a compromise between very hard usage and very conservative usage.

The equipment designer should appreciate (at least in a vague way) that no two tubes of a given type are alike. For example, they can differ in the position and shape of their characteristic curves. This is only one of the many kinds of differences between tubes that are coming under increased control in the testing specification. For example, some tubes now must meet three sets of limits for trans-conductance at three different bias values. This requires that the  $S_m$  vs.  $E_{c1}$  curve fall within certain limit curves at the specified conditions. It does not, however, indicate the same kind of control at other values of potentials where the  $S_m$  vs.  $E_{c1}$  curve will be quite different. Plate current is also controlled at two points on an  $E_b$  vs.  $E_{c1}$  curve, but nowhere else, and the conditions used to check these points can differ a great deal from the application conditions.

The values for various characteristics listed under the column headed "Bogey" are the typical values at the test conditions. They are the values that will most often be encountered in a tube when large groups of tubes are considered. In some cases, where the distribution of a particular characteristic is symmetrical around some center value, the bogey will be that center value or the mean value. In cases where the distribution is not symmetrical, bogey is still the value most often encountered and is called the mode. In this case, it will not be the center of the distribution.

The characteristic limits listed at the right side of the MIL-E-1B testing specification are of two types. One is the minimum and maximum limits within which the tubes must fall. Only a small percentage are allowed outside these limits. The second shows limits that are controls on the amount of deviation of the average value of a sample of a lot from the specified bogey and the amount of spread of the tubes in the sample around the mean. Some of the most often used abbreviations and their meanings are listed below:

ALD - Acceptance Limit for Sample Dispersion

LAL - Lower Acceptance Limit for Averages of Samples

LRLM - Lower Rejection Limit for Median or Average of Samples

MRSD - Maximum Rates Standard Deviation

UAL - Upper Acceptance Limit for Averages of Samples

URLM - Upper Rejection Limit for Median or Average of Samples

The above list contains abbreviations for two systems of specifying variables control limits that are much the same. The present MIL-E-1B system uses ALD, LAL, and UAL to specify the limits for averages and dispersions. However, the LRLM, MRSD, and URLM system was at first used concurrently with the present system, before it became the standard set of abbreviations, and many tube-testing specifications still included in MIL-E-1B contain these abbreviations. It is to be expected, however, that the ALD, LAL, and UAL abbreviations will eventually be used throughout MIL-E-1B.

Notes. The notes shown for each tube type are sometimes general notes and may be referred to at the top of the specification sheet. Most, however, are shown under the conditions column alongside various tests. Chiefly, the notes contain additional information pertinent to making the particular test with which it is listed, or describe deviations from the basic military publication requirements for that type of test. In such cases, the note supersedes the requirements of basic MIL-E-1B, Inspection Instructions for Electron Tubes, and MIL-STD-105A, in the event there is conflict between their statements. Using the information provided in the conditions for a test, any notes that are shown to apply to that test, and the pertinent references in the above three military specifications, a complete description will be obtained of the way in which the test is to be conducted. That is, all the information needed to set up the test and determine whether a tube passes or fails is available from these sources.

To complete a description of the details of a MIL-E-1B testing specification, a review of a typical

Techniques for Application of Electron Tubes in Military Equipment/9/a table is given showing the electron tube ratings, characteristics, and detrimental properties, arranged according to whether they are frequently, occasionally, or nearly controlled. This table, with definitions of the categories, is fairly complete and is a convenient method of indicating the extent to which control by the tube manufacturer can be expected. Page 1 from the above-named publication is included verbatim for easy reference. It can be expected that in future MIL-E-1B testing specifications, at least some of the tube characteristics listed in the lower part of the chart will be moved up in the table.

#### TUBE CHARACTERISTICS

In the following table are shown typical specified percent spreads of various characteristics around the center or bogey values of indirectly heated cathode-type pentodes, triodes, and mixers. These spreads are representative of the variability to be expected in the characteristics at the specified test conditions of MIL-E-1B. Hence, they indicate the amount of variation that must be expected when designing circuits around these tubes.

These percent spreads are generally those most often encountered, but individual types can vary from these values, and the type contemplated should be checked. In designing reliable circuits, the circuit must be made capable of satisfactory operation with initial variations in tube characteristics of approximately these amounts.

Characteristic Distributions. It has been indicated in the "Specifications" section that no two tubes of a given type are alike. They differ in many ways, and one of the tube manufacturer's problems is to reduce the amount of variation.

One of the most fundamental differences is the way the electrical characteristics differ when read at the specified test conditions. The designer should be familiar with the manner in which production lots

Typical  $\pm$  percent variation from "Bogey"

Tube Type	$I_f$	$I_b$	$S_m$	$S_m^*$	$C_{in}$	$C_{out}$	$I_{c_2}$	$\mu$	$S_m(g_3 \text{ to } p) \text{ or } S_m \text{ (conversion)}$
Triodes	8	32	20	10 to 15	24	28		15	
Pentodes	8	35	20	10 to 15	17	20	50		
Mixers	8	40	20	10 to 15	20	20	60		50

\*Maximum percent reduction in  $S_m$  with 10 percent reduction in  $E_f$ .

reliable-type tube testing specification would be in order. This particular subject has been covered adequately elsewhere, however, and in the interest of space conservation, the interested reader is referred to the available articles. /7/ /8/

Before leaving the subject of specifications, it is felt to be advantageous to the new designer to refer him to a table that shows the amount of control exercised over various tube characteristics. In

and whole populations of tubes of a particular type are distributed and related, so that they can be used most advantageously.

The distributions in Figure 8-1, then, are typical of most vacuum tube designs when measured at the specified test conditions. Values have not been assigned, because these distributions are not taken from a specific type. In designing circuits, the distribution values, for the most part, can be



**TECHNIQUES FOR APPLICATION OF ELECTRON TUBES  
IN MILITARY EQUIPMENT**

**SECTION 1 -- TUBE PROPERTIES**

The electronic equipment designer may best visualize the ability of a specific tube type to satisfy a given circuit requirement by grouping its properties in five separate categories:

1. **RATINGS** -- The set of limiting values defining each individual operating condition within which the tube type can be expected to yield a nominal period of satisfactory service.

2. **CONTROLLED CHARACTERISTICS** -- Properties of the tube essential to the operation of the circuit and existing within a distinct range of values, defined for a given type number by specification.

3. **UNCONTROLLED CHARACTERISTICS** -- Properties of the tube essential to the operation of the circuit, but of indeterminate range of values owing to lack of specification control.

4. **CONTROLLED DETRIMENTS** -- Inherent tube properties which must be considered in circuit design on the basis of their detrimental effects upon circuit operation. They have no specified range of values, but instead are restricted by a single specification limit upon the magnitude or frequency of occurrence of the property.

5. **UNCONTROLLED DETRIMENTS** -- Inherent tube properties detrimental to circuit operation, which are not subject to specification control and, therefore, can be considered only in a qualitative manner.

Since some characteristics and detriments will be controlled for one tube type, but not for another, both controlled and uncontrolled properties are treated in this handbook under their respective titles -- Characteristics and Detrimental Properties. Table 1-1 gives an indication of the general tendency toward specification control of these properties.

RATINGS	CHARACTERISTICS	DETRIMENTAL PROPERTIES
<b>FREQUENTLY CONTROLLED IN SPECIFICATIONS</b>		
Heater Voltage Anode Voltage (d-c) Screen Grid Voltage (d-c) Heater-Cathode Voltage Anode Dissipation Screen Grid Dissipation Output Current (Rectifiers) Output Voltage (Rectifiers) Peak Current (Rectifiers) Peak Inverse Voltage (Rectifiers) High Impact Shock	Transconductance Plate Current Screen Grid Current Heater Current Inter-Electrode Capacitance Amplification Factor Power Output Emission Conversion Conductance	Control Grid Current at Rated $E_f$ Heater-Cathode Leakage Microphonics Noise Shorts and Continuity Vibration Output
<b>OCCASIONALLY CONTROLLED IN SPECIFICATIONS</b>		
Anode Voltage -- Peak Forward Anode Voltage -- Peak Inverse Control Grid Voltage Control Grid Resistance Average Cathode Current Bulb Temperature	Dynamic Plate Resistance Bias For Plate Current Cutoff Bias for Transconductance Cutoff*	Electrode Insulation Grid Current at Elevated $E_f$ Change of Characteristics with Life Change of Characteristics with $E_f$
<b>RARELY CONTROLLED IN SPECIFICATIONS</b>		
Pressure -- Temperature Derating Peak-Pulse-Cathode Current	Zero Bias Plate Current Zero Bias Screen Current Plate Current at Multiple Bias Points Screen Current at Multiple Bias Points Transconductance of Multiple Bias Points*	Initial-Velocity Electron Current (Contact Potential) Electron Coupling Effects Plate Emission Screen Emission

\* Added to original Table 1-1

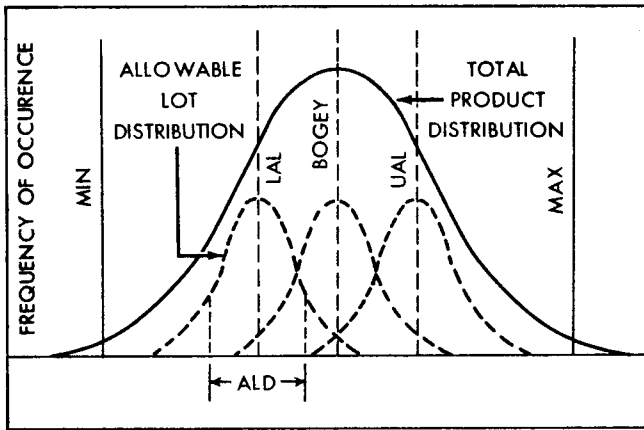

Figure 8-1. Typical distribution of  $I_b$ ,  $S_m$ ,  $\mu$ ,  $I_f$ ,  $I_{c2}$  and capacitance

obtained for a tube type from the testing specification sheet.

The normal, or symmetrical, distribution is typical for the characteristics usually considered most important. It is to this type of distribution only that the present type of variables controls are applied and have meaning. The curve shown demonstrates how the total product distribution is related to the various lots distributions and how control of mean and dispersion are accomplished.

The averages or means of the samples from acceptable production lots must be between a predetermined allowable lower limit (LAL) and upper limit (UAL). The dispersion of each lot is controlled by requiring that the average range of a group of samples from the same lot be not more than some predetermined allowable lot distribution (ALD). It should be apparent that such control of each lot will produce a total product distribution of the normal type.

The distribution in Figure 8-2 is typical of such characteristics as control grid current and heater-to-cathode leakage current. These characteristics tend toward zero, with fewer tubes reading higher. Those that measure above the testing specification maximum are out of control for one of a number of possible reasons and are discarded by the tube manufacturer. Progress in reducing the amount of these currents is reflected in lower maximum values in the reliable-type testing specifications.

The skewed-type distribution (Figures 8-3 and 8-4) have a left or right skewness. The first type is typical of plate resistance and audio-frequency noise. The second, or right, skewed type, however, is typical of plate current at cutoff bias, power output, and vibration noise. Some of the characteristics of both skewness types, because of their circuit effects, should be as high as practicable. Hence, for plate resistance and power output, a minimum figure only is specified. For others, which are detrimental to reliable (or even satisfactory) circuit operation, their amount should be reduced as much as possible. Thus, for such characteristics as cutoff

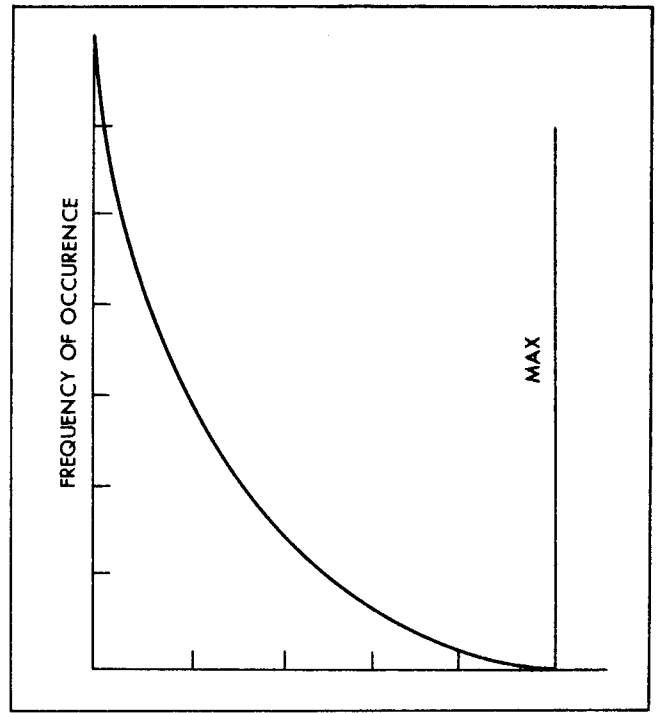

Figure 8-2. Typical distribution of  $I_{c1}$  and  $I_{hk}$

plate current, vibration noise, and audio-frequency noise, a maximum is specified.

Almost without exception, characteristic curves included in handbooks and data sheets are average or typical curves. They describe the amount of change in the important characteristics only as test conditions are varied, and a number of curves are given to describe completely the characteristic changes. When correctly done, the curves are based on a tube that has bogey characteristics at the specified test conditions.

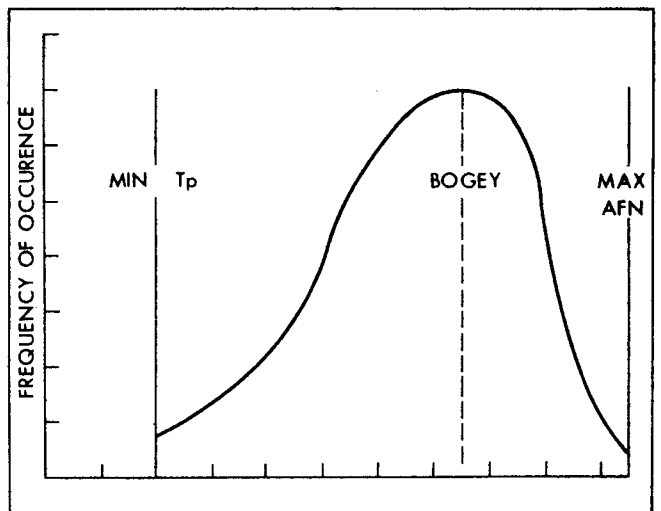

Figure 8-3. Left skewed distribution

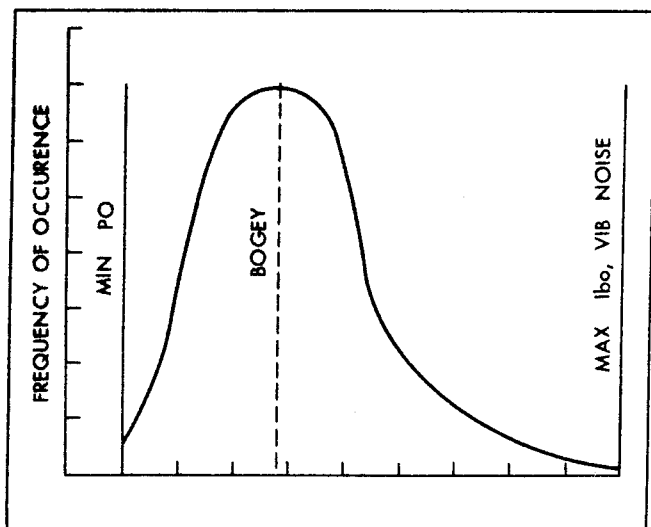

Figure 8-4. Right skewed distribution

These curves, however, do not contain any information about the variation of the other tubes of the same type around the characteristics of the bogey tube. The characteristic curves in Figure 8-5 describe in a generalized form the manner in which the total production of a type varies around the average curves.

This curve shows the spread of the product around the familiar triode plate characteristics. In this instance the spreads around the bias curves do not overlap, and in some types this will be the case. Other triodes will exhibit overlap of the spreads, and the amount will vary with the bias values selected and the tube type. Although specific curves will differ from the relative spreads shown here, these curves demonstrate the pattern of the spread to be expected in all types as the operating voltages are changed. It is characteristic for the absolute amount of spread

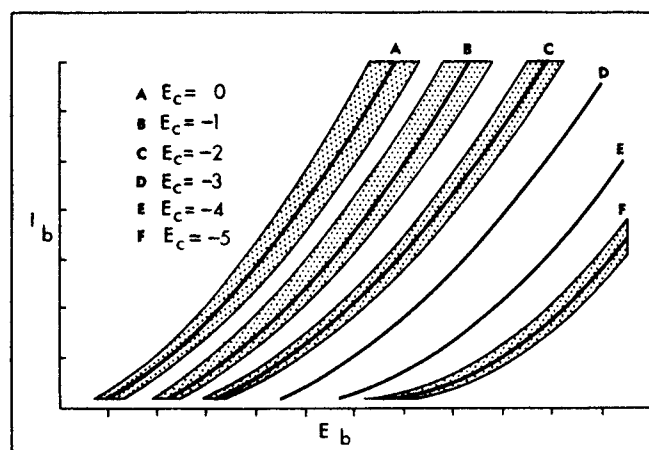

Figure 8-5. Triode plate characteristics — Effects of variation of  $E_c$

to decrease as the amount of current drawn decreases. That is, lower plate voltages and higher bias voltages reduce the absolute differences in plate current between tubes.

Effect of Heater-Voltage Variations. Figure 8-6 shows the effect of a  $\pm 10$  percent variation in heater voltage on one of the triode plate characteristics. The increased heater voltage moves the limit curves upward from those for the normal or specified heater voltage. Of course, the average curve is moved upward also. Conversely, the reduced heater voltage causes a lowered position of the  $I_b - E_b$  limit curves. The amount of change in the plate current limit curves at  $\pm 10$  percent  $E_f$  may depart as much as 20 or 25 percent from the values at specified heater voltage.

The amount of plate current change (and other characteristics) varies with the operating plate voltage and the emission-temperature characteristic of the cathode. If a 10 percent change in heater voltage occurs over a flat portion of the emission-temperature characteristic, the resulting change in plate currents will be small, and the upper and lower limits of the spread will be affected equally. If the emission-temperature characteristic is not flat, the change in plate current limits will be greater. The amount of change of the upper and lower limits may not be the same for the  $+10$  percent  $E_f$  and  $-10$  percent  $E_f$  values. In some instances it may be found that a proportionately greater drop will occur for the lower limit of the  $-10$  percent curve. Here, as is the case in applying the other curves to specific tube types, data on the effect of heater voltage variation on the characteristics of a tube should be obtained for the tube under consideration.

There have been indications, although the point should be investigated more thoroughly, that  $E_f$  variations affect triode characteristics. Everything else being equal, such as design considerations, cathode

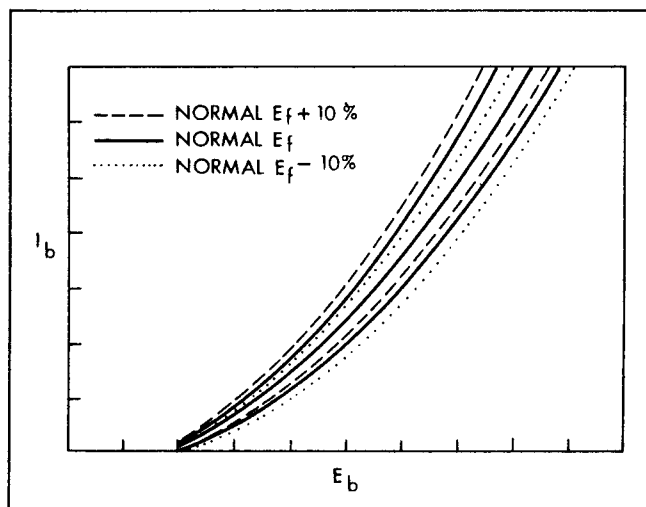

Figure 8-6. Triode plate characteristics — Effects of variation of  $E_f$

activity, and operating level, triodes appear to have greater total characteristic spread when one considers the change from the -10 percent  $E_f$  voltage to the +10 percent  $E_f$  voltage. The differences for plate current and transconductance are of the order of a few percent more for triodes.

Transfer Characteristic Variations. The transfer characteristics of triodes vary generally for the entire production in the same way that preceding plate characteristics do. Figure 8-7 illustrates that  $S_m$ ,  $\mu$ , and  $r_p$  also experience increased variability as the level of the tube operation is increased. Although the effects of plate voltage and heater voltage variation on  $S_m$ ,  $\mu$ , and  $r_p$  have not been shown, they would alter the position of these characteristics up and down in much the same way they did for plate current. Hence, the effects of heater and plate voltage variation on these characteristics should be considered when choosing a tube for a particular application.

Figures 8-8, 8-9, 8-10, and 8-11 depict the type of characteristic variation within a total production of pentodes in much the same way as that shown for triodes.

It is also true of pentodes that higher operating levels produce greater spreads in the characteristics

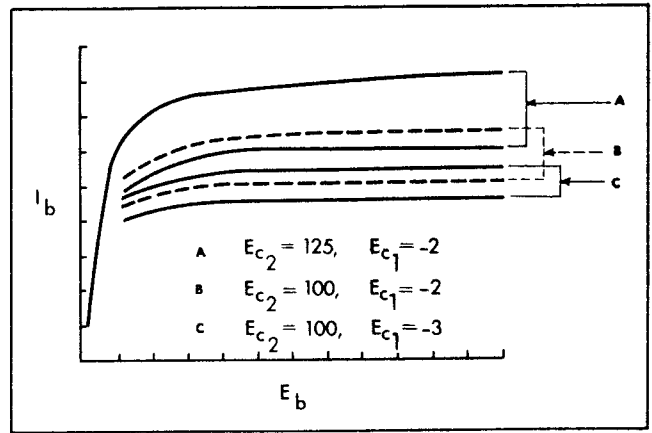

Figure 8-8. Pentode plate characteristics — Effects of variations of grid potentials

and that more uniform operation results from conservative usage. Using typical screen voltages, it can be seen in Figure 8-8 that a tendency for the spreads to overlap exists between the curves where bias changes by a volt. It appears that this tendency to overlap is greater in pentodes than in triodes, as demonstrated in Figure 8-5. Of course, this overlap is also to be expected in the pentode  $I_b$  vs.  $E_{c1}$  curves.

#### LIFE-TEST CONSIDERATIONS

Tube manufacturers are required by the MIL-E-1B testing procedures to conduct a life test on a sample from each production lot. The number of tubes in these samples is now adequate to determine statistically within levels of assurance whether the lot represented has acceptable life characteristics. Consequently, the quality of the life characteristic is maintained for the total production at least to the levels specified, whereas previous sampling provided only an unsatisfactory indication.

A sizable portion of the life-test data taken under specified conditions in the earliest periods of reliable-tube development showed real improvement

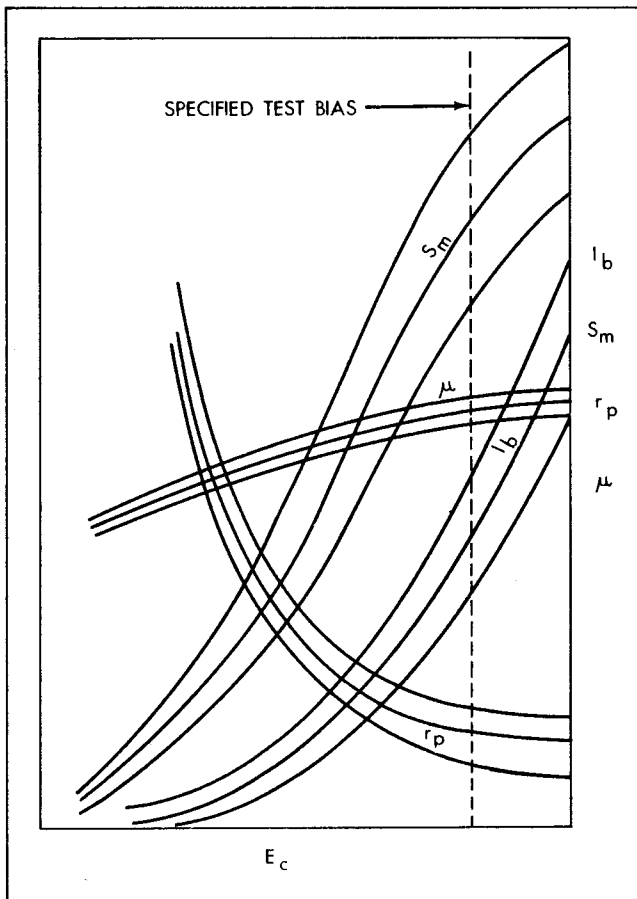

Figure 8-7. Triode transfer characteristics

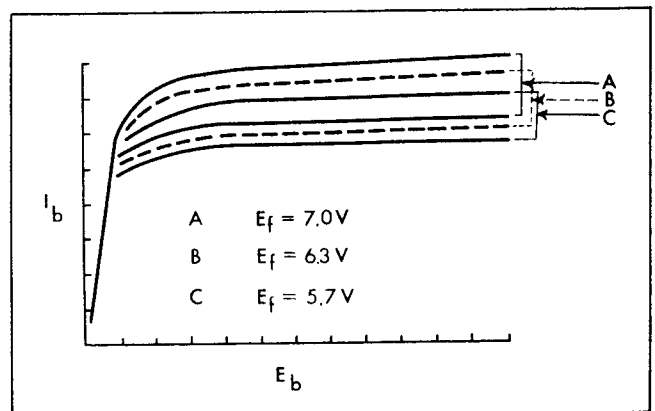

Figure 8-9. Pentode plate characteristics — Effects of variations of  $E_f$

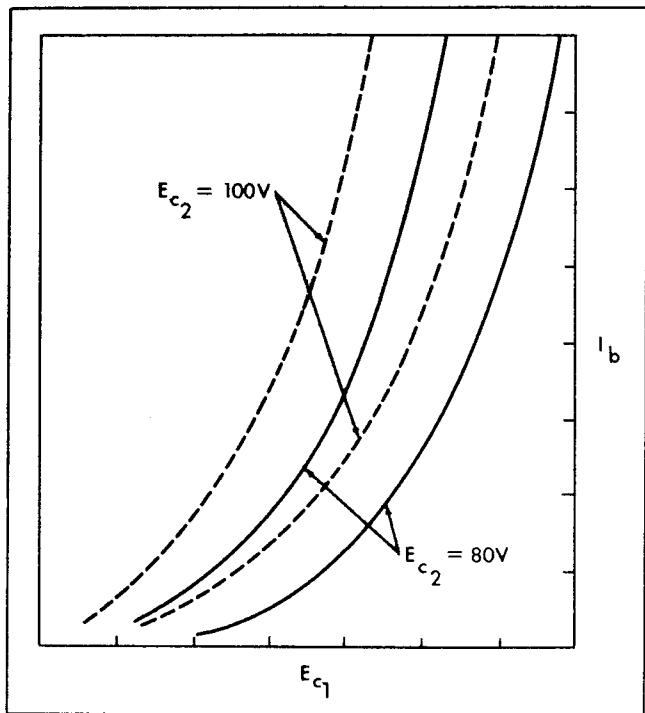

Figure 8-10. Pentode characteristics --  
Effects of variations of  $E_{c2}$

when compared to their less reliable predecessors. Some of this information was published, and it showed that overall failure rates were only fractions of what they had been before. The primary reason for this decrease was the reduction in the early incidence of catastrophic failures. This improvement resulted from such things as improved heaters and control of shorts between elements. In all reported data, the failures in later life were due to impaired characteristics caused by emission decay.

Most of that published data is now obsolete, for a variety of reasons. Because it related only to the earliest periods of reliable-tube design and investigated the improvements of the early efforts, it does not reflect the additional experience or the more settled production processes of today. Further improvements in tube quality have been accomplished as increased effort was expended toward better parts control and process control. Also, life-test specifications now require more information in the form of additional life-test end points, thus tending to increase the apparent rates of failure. In some instances, the old end points set for characteristics such as  $S_m$  have been raised to higher values, and comparable rates of failure are sometimes in reality sizable improvements in quality. Such changes in designs, manufacturing techniques, and specifications have appreciably improved the reliability of tubes for life so that data a few years old can be misleading.

The accumulation of enough life data to obtain trustworthy indications of reliability is timeconsuming. At the rate of 20 hours per day, approximately eight-and-one-half months must elapse to complete a

5,000-hour life run. Specifications require only that a minimum of five tubes per month must be started on this long life test. No doubt, the majority of manufacturers run life tests on more tubes than the minimum required, but the greatest problem usually is in providing enough life-rack space to test the necessary quantities. Therefore, it is customary to accumulate data over a period of years before enough is obtained to yield adequate information.

During the last two years, little or nothing about the results of acceptance life tests has been published. One article, which touched on the problems of obtaining dependable failure-rate indications and described in detail the large number of different theoretical failure patterns that might be obtained, was issued. /7/ Some contract reports of evaluations of tube failures in military equipments have been issued by ARINC. At least one of these presents failure data on eight tube types made in 1952 by three manufacturers. Catastrophic failures were 1.6 percent of the total tubes installed, while 23.2 percent, the largest group, failed for deterioration-type defects. In general, removal rates followed a normal distribution, remaining constant up to approximately 3,000 hours, then increased at an accelerated rate as the tubes began to wear out.

When one reflects on the time consumed and the tube quantities that must be life-tested so that an adequate amount of data will be obtained, it soon becomes apparent that a circuit designer would be the most fortunate of men if the tube manufacturer were to supply him with dependable failure data covering the designer's conditions. His good fortune would become even more apparent if one were to

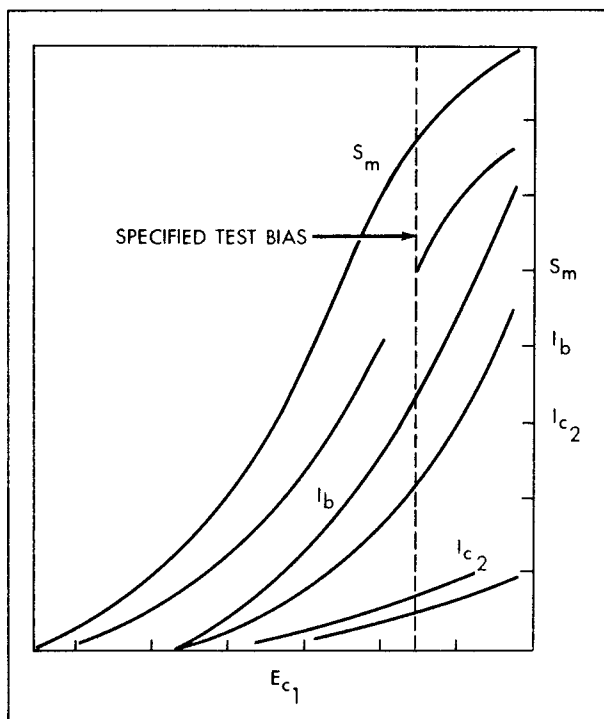

Figure 8-11. Pentode transfer characteristics

review the number of reliable-tube types a single manufacturer makes and the infinite number of possible operating conditions for each. Such an ambitious life-test program to obtain data at all conditions is not practical because of time, cost, and the probable amount of information required relating to specific uses — since discrete increments in conditions would have to be used and considerable interpolation would have to be carried out anyway.

Failure information of tubes in equipments, collected through a planned and controlled program, is the most indicative type. It has the advantage of testing the tubes in actual use over the specific ranges of dissipations, current drains, and voltage fluctuations with which the designer is concerned. When evaluated, the data can indicate pertinent design weaknesses in particular tube types, compare reliability of various manufacturers, and point out improper circuit designs whose failure rate is higher than other circuits using the same tube type. Hence, more diverse information relating to specific usages is obtained than is possible from the tube manufacturer. Reliability improvement would be accelerated if more programs of this type were initiated.

From analyses of life-test data, the tube manufacturer can supply information about the expected direction of change of electrical characteristics. For equal operating conditions, or conditions close to the specified life conditions, he usually can indicate the amount of change to be expected in such characteristics as transconductance, leakage currents, and balance between sections of dual types. The following curves are typical examples of this type of information.

**Transconductance Changes.** At specified test conditions, it can be expected that  $S_m$  will decrease in a manner similar to that shown in Figure 8-12. The decrease is caused by slow evolution of gases within the tube, which poisons the cathode coating and reduces emission, and the development of impedance in the interface between the cathode sleeve and its coating. Deterioration caused by the evolution of gas can be expected to be low in reliable-type tubes, in

comparison to what it was in early types, because of the increased care in fabrication and the safeguards that life-testing provides. The effect is cumulative but varies slightly between production periods because of small changes in processing and parts condition. Quite likely, the glass envelope and mica spacer are the principal sources of whatever gas develops, with the latter probably the worst offender.

Interface impedance accounts for a relatively greater amount of the decrease in  $S_m$  observed than was true before gas became as well-controlled as it is today. Whether gas or interface impedance now contributes the greater amount to  $S_m$  decrease during life varies with the tube type and is dependent on such factors as cathode temperature, processing history, variation in contaminants in the parts, and severity of use. The effect of the development of interface impedance, however, has become more apparent and increasingly significant in investigations into the causes of the decrease in tube quality with life.

The amount of  $S_m$  reduction shown in Figure 8-12 varies widely from type to type, but the amount of decrease allowed by the life-test end point specified will give relative indications of the rate of decrease that can be expected under life test conditions. These indications do not necessarily say that the relative decrease rates will be similar under other conditions, and the circuit designer who relies on them under varied and diverse conditions will jeopardize reliability.

**Leakage.** Heater-to-cathode leakage current normally changes as shown in Figure 8-13. Because of hum and coupling effects, this current should be as low as possible. On static life test with the cathode positive with respect to the heater by some specified potential, it is found that heater-to-cathode leakage decreases rapidly in the early hours of life. After a few hundred hours, the measurable current, for practical purposes, is so low it is often recorded as zero.

The four smaller curves included represent the shape of a typical  $I_{hk} - E_{hk}$  curve and the manner in which it changes during life. Curve (1) shows the relation between  $I_{hk}$  and  $E_{hk}$  at the beginning and early hours of life. Usually, the positive side of the curve has higher leakage values than the negative side. However, this relationship can be reversed by a number of production controls, so that the negative leakage becomes greater than the positive, although both have been reduced. The other curves, numbered (2), (3), and (4), depict the changes observed as hours of life are extended.

Interelectrode insulation is most commonly read between grid and all other elements tied together, and between plate and all other elements tied together. Specified heater voltage is applied, and either 100, 300, or 500 volts dc is applied between elements, depending on the tube voltage rating, with the polarity such that electron currents do not flow. The curves of Figure 8-14 show typical distributions of these insulations at zero hours and 500 hours. The curves

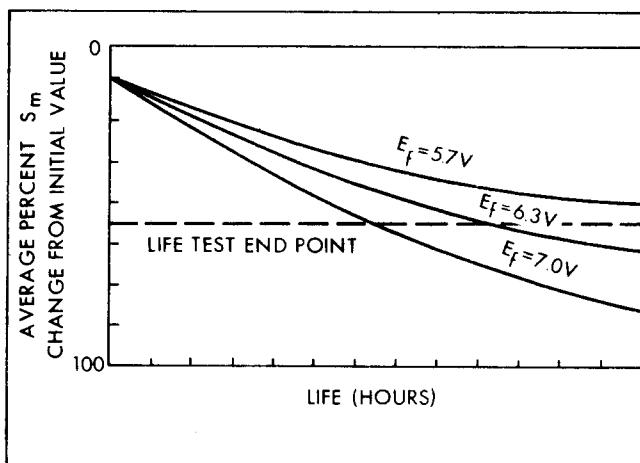

Figure 8-12. Typical  $S_m$  change vs. life

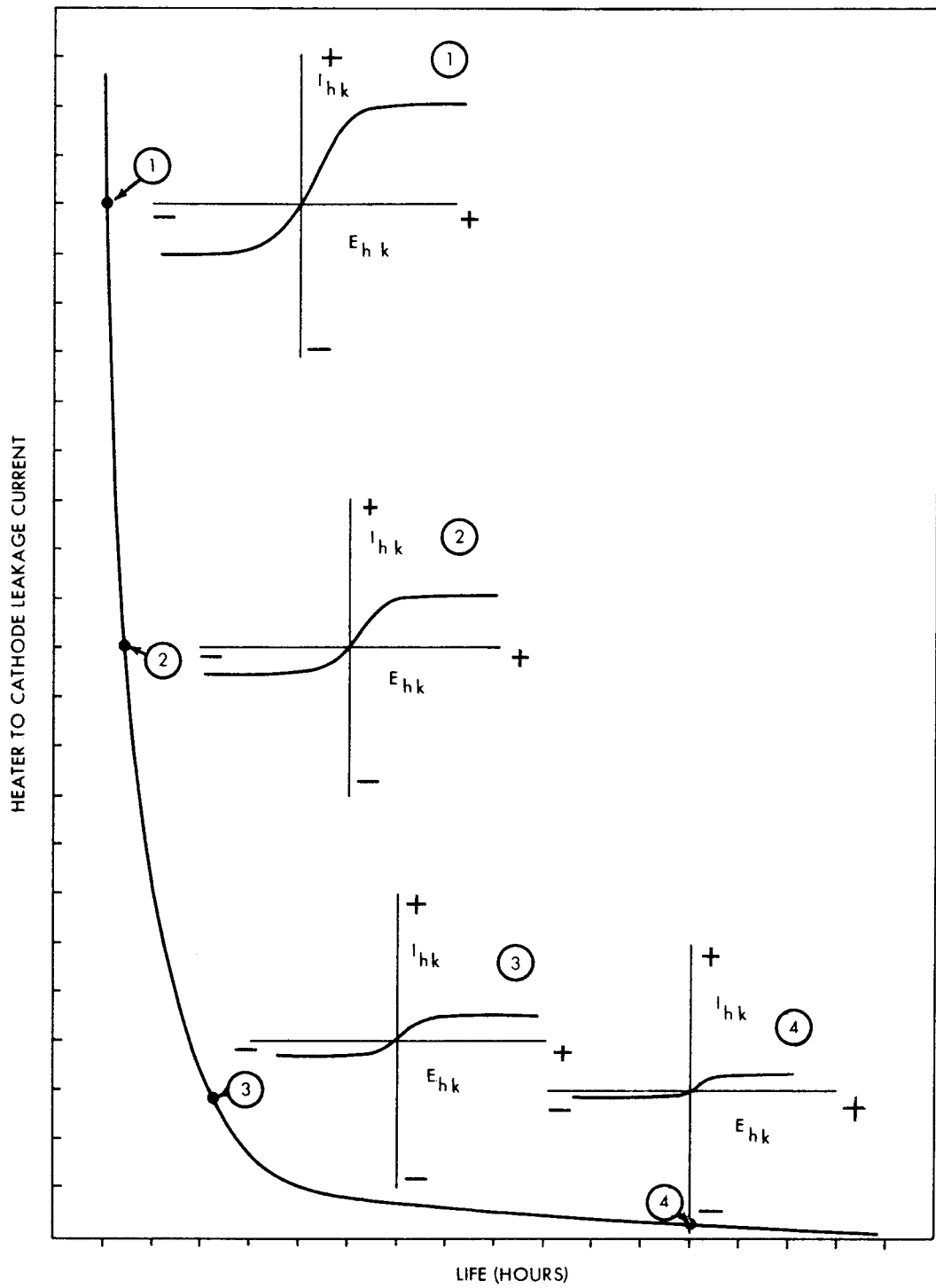

Figure 8-13. Typical  $I_{hk}$  change vs. life

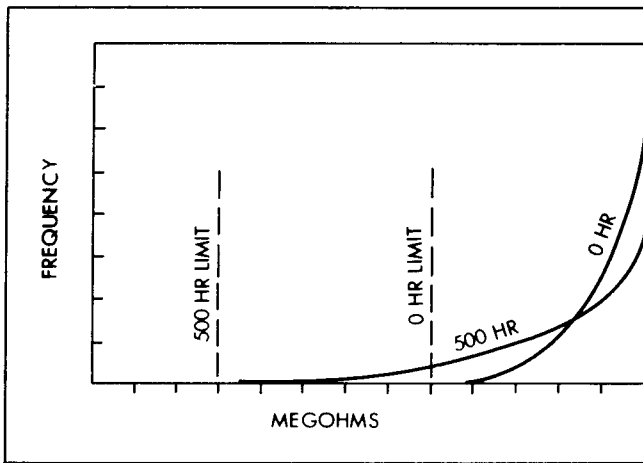

Figure 8-14. Electrode insulation vs. life

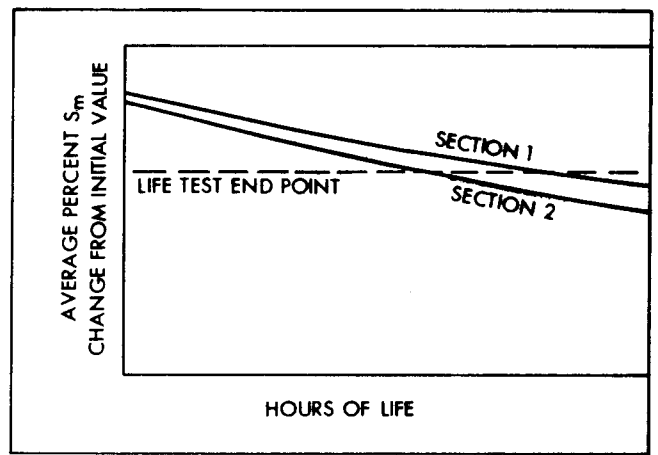

Figure 8-15. Typical  $S_m$  balance between sections vs. life

demonstrate the tendency for the distribution to shift toward the lower resistances. The change is typical for both g-all (grid to all other elements) and p-all (plate to all other elements) resistance. Experience has shown that the same order of change occurs at an earlier time of life in the presence of elevated ambient temperatures.

**Dual-Tube Balance.** In some dual types, it is important that the characteristics of the two sections be as much alike as possible and remain so throughout life. This is exemplified in reliable twin triodes, some of which now have limits specified for plate current differences initially and at the end of life. Generally, the same is also required of  $S_m$ , and the plate current change can be used as an indication of  $S_m$  change, since they vary in the same direction, but at different rates. The curve given in Figure 8-15 illustrates how  $S_m$  can be expected to diverge gradually as hours of life increases.

The tube user can expect some amount of divergence in every dual tube, with some differences in the amount found in various types. It results from the never-repealed law of nature that no two individuals are exactly alike. There is the further complication that man manufactures radio tubes. To produce well-balanced tubes in quantity, it is mandatory that the designs of the two sections of the dual types be identical and that the exactness be preserved during fabrication and processing. Thus, it is a problem of manufacturing control. Further knowledge of emission control will add significantly to the controllable degree of balance.

**Life vs. Off-Standard Operation.** When tubes are operated at conditions other than their specified static test conditions, the rate of failure changes and the relative frequencies of failure causes change in a way that is dependent on how conditions were altered. In most instances, more conservative usage, such as lower dissipations and current drains, promotes longer life and fewer failures. Conversely, more stringent conditions result in higher rates of failures. For example, an increased rate of failure may be caused

by additional sudden failures, such as heater burn-outs at high heater-voltage conditions. Or, it may be caused by a more rapid deterioration in cathode activity, which may not affect circuit operation too adversely until some period of time has passed. The evolution of gas and cathode poisoning resulting from high plate dissipation will decrease useful life.

Deviations from the rated heater voltage can be detrimental. If the heater is well-designed, and meets a heater cycle test of +110 percent of specified heater voltage, the rate of heater failure over a few hundred hours of life at increased heater voltage will be affected by only a small amount. This amount may be sufficient, however, to turn a borderline circuit into a circuit that is just not good enough. In multi-tube equipments where the overall reliability must be high, increasing heater voltage by 10 percent could make individual tube failures, and thus the overall failures, unacceptable.

Data in which increased heater voltage was accompanied by other overvoltages, such as maximum heater-to-cathode voltages, showed that failures caused by heater-to-cathode leakage and open cathodes had become appreciable. Generally, it is better to err on the conservative side and attempt to keep variations on the low side of specified heater voltage.

Life tests conducted with the plate dissipation greater than bogey will produce higher rates of failure. Failure patterns will differ according to the cause of excessive dissipation. For example, the pattern resulting from failures caused by excessive plate voltage will differ from those caused by excessive cathode current.

If extreme voltages are used, leakage currents between elements may increase or break down and arc-over may occur between elements. In less abusive cases, there should be expected an increase in gas, the evolution rate of which would be related to the degree of overvoltage and the observed decline in emission. When the dissipation of an element is sufficient to raise its temperature to red heat, gas evolution may result in the loss of emission in a few hours.



High dissipations, accomplished by lower than maximum element voltages and high cathode current drains, require low bias voltages. In oscillator circuits, these conditions are attained by swinging the control grids well into the positive region. Because peak emission availability is often of the order of 100 times the steady state current at the specified test conditions, there are indications that this type of operation will be less injurious than the steady state condition, so long as the temperature saturation point of the cathode is not exceeded. For comparable dissipation levels, there is less tendency for the tube to become gassy. Advantages remain, however, in restricting operating temperatures as much as possible.

When a tube is operated beyond its maximum current capabilities, there will be no further gain in emission, and distorted waveforms will occur as the positive half cycle is flattened at the peak, because the emission rate of the cathode is not sufficient to supply the quantity of electrons required. Deterioration of the cathode coating will be accompanied by a certain amount of gas and high electrostatic field concentrations, leading to arc-overs from grid to cathode.

Accelerated Life Test Considerations. The intent of accelerated life testing has been to attain the same failure pattern in a fraction of the usual 500-hour test, at perhaps 150 or 200 hours or even less. The same sort of accelerated failure would be applicable at a somewhat longer time for the present 5,000-hour life test. Accelerated life tests are of no value for acceptance as a substitute for the 500-hour test unless it can be demonstrated that correlation exists between the failure results in the shortened time and the normal 500-hour results. Conditions more stringent than customary have been tried to accomplish such correlation, and from time to time, accelerated life tests have been used for lot acceptance.

With the advent of long-life tubes has come a renewed interest in accelerated life tests as a relief from the problems of large life-test facilities and stocks awaiting decision to release or reject. At least one large program sponsored by one of the Services has been conducted to determine the feasibility of such testing. The results did not produce a universal, correlated method of accelerating life, but they did provide information on the effects of greater-than-specified operation conditions.

Specifically, with increased operating conditions an attributes acceptance procedure was established for gas arc failures at 18 hours for type 12AU7. The procedure was at least equivalent to a 500-hour test under normal conditions. A second method was also successful in predicting long-life inoperative failure to 10,000 hours on type 12AU7 and 25,000 hours on type 6SN7GT on the basis of the specified 500-hour life information. The extrapolation procedure used was cumulative percentage failure based on a logarithmic normal distribution of inoperative failures. Generally, the attempt to correlate accelerated electrical characteristic slump with specified life was not successful.

Effect of Temperature on Life. High-temperature operation will increase failure rates in instances where such exposure results in high bulb temperatures. Possibly the best example of the expected differences can be found in an article by Marcus A. Acheson and Eleanor M. McElwee. /10/

The article reports on two groups of life data on reliable-type subminiature tubes. One group of 555 tubes was life-tested at specified test conditions and room temperature, while another group of 149 was operated at the same electrical conditions and 175 C ambient temperature. Operating bulb temperatures of the 175 C life group approached the absolute maximums specified for the various types.

The curves in Figures 8-16 and 8-17 illustrate how the high-temperature operation produced higher failures throughout 5,000 hours. The initial failures included gas and characteristic-deterioration failures not encountered initially in the room temperature test. The detrimental effects of the elevated temperatures were present practically from the beginning of life. They would be expected in other tube types, as well as in those tested. The curves also demonstrate that the failure rate at high temperatures increases very rapidly compared to the eventually constant failure rate at room temperature.

The curves of Figures 8-16 and 8-17 illustrate how high-temperature operation increases the various causes of failure. It can be seen that this type of environmental condition results in high rates of gas evolution within a tube. The failures shown as characteristic-deterioration can, for the most part, be considered also as gas failures, whose rate of gas evolution was not high enough in any period to be measured as excess gas, but, nevertheless, were present in quantities sufficient to increase markedly the rate of characteristic slump. It seems reasonable that all tubes will have similar histories when subjected to high-temperature operation.

There will be some additional failures at high temperature as a result of glass electrolysis. In some cases it is found at the glass-to-metal seals

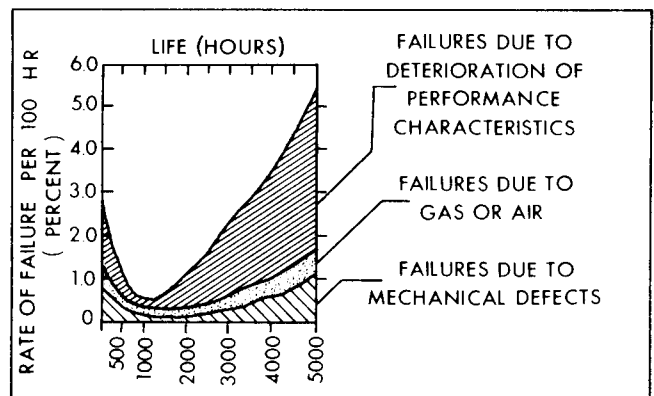

Figure 8-16. Breakdown of failures during life; 149 premium subminiature tubes at 175 C ambient temperature

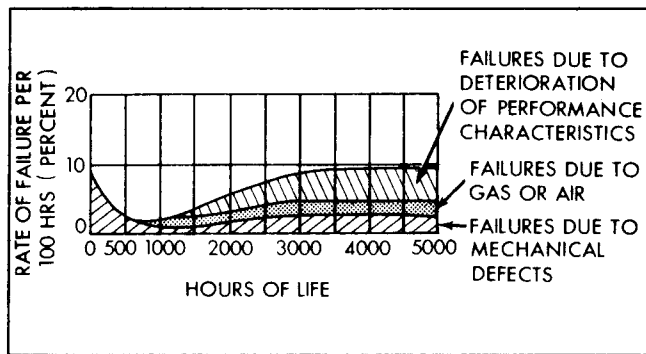

Figure 8-17. Breakdown of failures during life; 555 premium subminiature tubes at 30 C ambient temperature

where the leads go through the glass to the internal elements. Electrolysis is a function of operating temperature, potential difference between the leads, the distance between leads, and the type of glass used. It occurs most readily in the so-called "soft" glasses, which are most commonly used in radio tube manufacture.

When electrolysis is present, the lead seal eventually becomes dark gray or black along its length. In d-c operation it forms most heavily along the negative lead of two adjacent leads whose potential difference is high. Continued operation produces an extension of the black deposit from the negative lead through the glass stem toward the positive lead in a feathery or fan-shaped pattern. Further operation will eventually result in loss of the seal and vacuum, thus producing an air tube. In the advanced cases, cracking of the glass may also occur between the leads.

In most tubes, the point of maximum bulb temperature occurs at a point opposite the plates. This point can vary with the type of mounting and shielding used, and if heat conduction through the leads is high, the highest bulb temperatures in sub-miniatures and miniatures will be found in the stem. Manufacturers agree that the absolute maximum bulb temperature is about 250 C. This figure is referred to the hottest part of the tube, and large differences can be found between the highest and lowest temperatures throughout the length of a given tube. It is recommended that the temperatures experienced along the length of the bulb be known for specific applications. The maximum recommendations of the tube industry should not be exceeded. It is still wiser to include whatever temperature-reducing techniques can be employed and not to plan to operate at the absolute maximum. Keep in mind the failure differences shown in Figures 8-16 and 8-17.

There are a few reliable tubes that have been developed for higher temperature operation. These utilize "hard" glass and are rated at 300 C. For applications where reliable operation is required in the presence of raised temperatures, the additional cost of these tubes may prove worthwhile.

In the applications in which entire equipments are subjected to high ambient temperature, the cooling

problems are greatest. Cooling air or cooling fluid must be used to carry off the heat generated and reduce operating temperatures to the lowest practicable. Cooling fins and radiators must be so designed that efficient heat transfer is effected. The problems often become complex because of the operating temperature requirements and the safe temperatures of components for reliability. These cases usually can be improved to the acceptable temperature level by variation of the cooling air temperature, the use of baffles in addition to fins, and the routing of the cooling air over the coolest components first and the hottest last. (Refer to the chapter on Mechanical and Environmental Factors.)

Temperature-Reduction Techniques. Whether the entire equipment operates at high temperatures or not, the tubes mounted in sockets with no other provision for heat transfer can be expected to reach temperatures above those of the chassis and the surrounding air.

Considerable reductions in bulb temperatures have been attained by the technique of embedding the tubes in large mass blocks, which have high heat conductivity. Good contact between the tube and block is usually accomplished by high-conductivity springs or shims. Bulb temperatures in such cases have been reduced to the temperature of the surrounding block.

Sizable temperature reductions can be achieved by increasing the number of leads to a tube socket, by using tight-fitting shields of high temperature conductivity that are fastened to the chassis or a large radiator, and by dispersing high temperature components, such as power transformers and other tubes, so as to reduce the radiated heat within a given volume. The amount of heat removed by conduction can easily be made greater than that removed by convection and radiation.

Loose-fitting shields should be avoided, because the dead air enclosed by the shield will serve as a heat insulator. Strips of tubes should not be enclosed in cans or covers unless other means are provided for conducting heat away. Without such conduction, it has been found that even perforated covers will result in increased bulb temperatures. Neither should tube bulbs be potted in plastics, coated with materials to blacken them, or sandblasted with the expectation that heat radiation will be improved. Such practices actually reduce the amount of radiation, with the ultimate result of increasing temperature.

The fact that reliable-type life tests are cycled life tests, that is, all voltages are turned on and off according to a schedule, was described in the "Life Test" section of Specifications. The experience gained in comparing life tests that have been cycled with the tests that have not been cycled is also useful to the circuit designer.

Cycling Effects. Generally, it appears that well-designed heaters will suffer little from increased burnout rates as a result of cycling. Early in the development of reliable-tube types, there were instances

of increased burnouts and open filament tabs. Design changes and quality inspections, plus the heater cycle acceptance tests now included in the testing specifications, have reduced their occurrence to the point where they are problems no longer. In reliable types, there is no reason to believe that cycling produces a more rapid decrease in electrical characteristics.

**Cathode Interface Impedance.** This has been established as the cause of "sleeping sickness" — the deterioration in pulse characteristics after hours of standby operation in which only heater voltage is applied. The problem is particularly perplexing in computer applications. Reliable-type tubes and special tubes for computer use now contain cathodes whose percentages of contaminants, particularly silicon, are held to very low levels, so that the problem is greatly reduced.

Even in tubes whose silicon content is not reduced, interface impedance is low or essentially absent at first, depending on the processing schedule of the tubes. When life tests for tubes are made at cutoff conditions, it develops more rapidly and can reach a value of the order of 100 ohms in a few hundred hours. When tested at intervals during cutoff life test, some tubes exhibited wider spread in transconductance and sometimes had increased gas content.

In normal life, interface impedance does not increase as fast as in cutoff life, but even in some reliable types it can become as high as a few hundred ohms in about 5,000 hours. Studies have shown that one of the main causes of decrease of transconductance during life is interface impedance, and there is the strong possibility that transconductance change can be predicated by early life interface growth.

Because interface impedance increases much faster on cutoff life than on normal specified life, it has been suggested that impedance growth during cutoff may be retarded by permitting the tube to draw low levels of current between pulses. It may be possible to design circuits to such conditions, but the between-pulse current levels would probably have to be held to less than a few hundred microamperes. Quite likely, the observed difference in rate of interface impedance growth between low-level operation of that order and cutoff conditions would be small and the benefits negligible.

**Dynamic-Condition Life Tests.** Failure rates on life tests under dynamic conditions can differ appreciably from those of static life tests. This is especially true on oscillator and pulsed-type tubes. Almost without exception, tubes with good pulse capabilities also have good static emission, but the converse is not necessarily true. For this reason, tubes intended for oscillator and pulsed applications receive such tests in normal acceptance testing.

On pulsed life testing, inadequately processed tubes become apparent much earlier in life. There may be a tendency to improve or to get worse rapidly as gas is emitted from the cathode and other tube parts. In such instances, the spread of characteristics between tubes becomes greater than that found on static life tests.

It has never seemed worthwhile to substitute dynamic life tests for static operation amplifier-type tubes, since conditions imposed by the latter are at least equal to class A operation. In the majority of types, the current levels are higher, so that static life is usually a more severe condition, and nothing is to be gained by the presence of a signal that does not drive the grid positive.

## VIBRATION CONSIDERATIONS

The presence of noise in an electron tube output as a result of vibrational excitation of the tube has received more attention than effect on tube performance of other environmental tests. This attention on the user's part has resulted from more severe vibrational applications and from the trend toward higher performance, thus revealing the need for greatly reduced vibrational noise levels. The manufacturer's attention has been a reflection of these needs, and substantial reductions in noise level have been accomplished. The improvements have been of the order of four or five times, and more in some specific types.

Vibrational noise originates from tube parts that move in relation to the other parts. Specifically, noise is generated when parts such as cathodes and grid legs are not held tightly in their mica holes or when heaters are able to move and bump against the inside of the cathode sleeve. Sometimes, the motion is parallel to the tube axis rather than perpendicular. Also, motion such as flexing of the micas and nose transmission through the structure from freely vibrating getters produces noise in the tube output. The tube structure as a whole must also be restricted so that it cannot vibrate in a cantilever action and strike against the inside bulb wall.

The elimination of vibrational noise generally requires that the tube structure be stiff and all parts be held tightly in place. This means that cathode sleeves and grid legs must fit tightly in the micas, and that provision be made for heavy support rods, stiff micas, tight-fitting mounts in the bulbs, and designs that include restricting parts to eliminate longitudinal motion. All these design features, plus great care in manufacturing, reduce peak noise levels to about 25 millivolts, with the arithmetic average appreciably below that.

A typical distribution of the vibration noise output for a group of tubes for a fixed frequency and acceleration level showing its relation to the testing specification limit is shown in Figure 8-18.

It can be expected that for reliable tubes, the position of the maximum limit with respect to the distribution shown in the above curve for fixed frequency vibration will be true of almost all types. The absolute millivolt value will vary between types, however. Amplifier triodes have the lowest inherent noise levels, with increasing levels in oscillator triodes and pentodes. When the limit is relatively low in comparison to other tubes in the same kind of use, the circuit designer can expect that the noise level of that particular design is low and is well

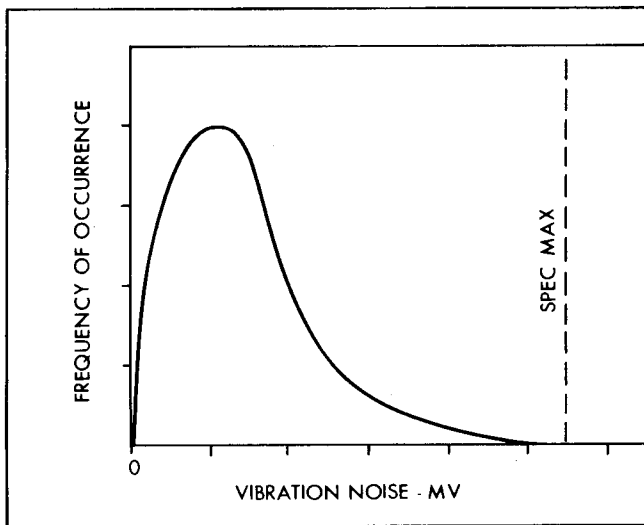

Figure 8-18. Typical distribution - Vibration noise

controlled during manufacture. For such a tube type, the arithmetic average of a large group of tubes will probably be of the order of one-fifth the maximum specified. For types whose specified maximum is high in relation to other types of the same kind of use (all other conditions of test being the same), it quite likely indicates somewhat inferior design or less control in manufacture or both. The arithmetic average of a large group of tubes of this variety will probably be of the order of one-tenth the maximum limit.

Vibration tests of various frequencies are not appreciably different when the frequencies are about 150 cycles or below. Unless the tube is defective or of unusual design, changes in noise level are insignificant until the vibration frequency is increased to the neighborhood of 200 cycles. At that point and above, noise levels can increase appreciably. Comparing types, one of which is tested at a fixed frequency below 150 cycles and the other above, is not justified. Obviously, higher acceleration levels produce higher noise levels.

As frequency is increased from the low fixed frequency already referred to, the resonant frequencies of the tube parts are reached and the parts are excited mechanically. At these frequencies, the noise output of the tube is increased. At up to approximately 1,000 cycles, there may be a few such resonant points of various parts of the tube structure. The resonant points vary with the tube type, and for some, the first resonant point is as low as 200 cycles. A few testing specifications show that specific types will be controlled so that resonances will not occur below 400 cycles, for example. In some tubes there have been no indications of resonant frequencies below 1,000 cycles. It should be expected that the noise characteristics up to 5,000 cycles for a group of tubes of the same type will vary, but the resonant points of each tube will be similar in frequency. A typical noise vs. vibration frequency plot at a constant acceleration level is given in Figure 8-19.

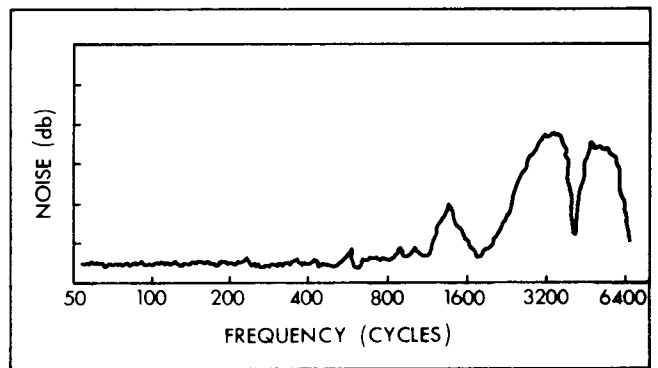

Figure 8-19. Typical noise vs. vibration curve

This plot represents a reasonably good tube. The general increase in noise level above 1,000 cycles is typical. Noisier tubes vary, from those having a few more resonant peaks below 1,000 cycles to those having relatively higher noise levels across the entire frequency range.

In most of the discussion so far, the noise generated in a tube has been the result of vibration at one frequency at a given time. Obviously, the tests in which vibration frequencies are swept over a range provide more information than a single-frequency test. In use, however, it is not unusual for tubes to be excited mechanically by complex waveforms having a number of frequency components or by short-duration, high-g shocks. When such excitations occur, noise levels can be quite different from the levels at fixed frequencies, because various parts of the tube structure may be simultaneously excited at their resonant frequencies.

There are as yet no standardized methods to test tubes under such conditions, but investigations toward that end are being conducted. The problems have been more difficult because of the frequency response limitations of vibration systems and the development that had to be done to obtain random or "white noise" sources. To be useful, the test must be reproducible as to frequency characteristics and be rapid enough to test tubes at production speeds.

In circuits where noise levels are a problem even with the best tubes obtainable, the designer can greatly reduce the vibration by using vibration isolators. It is not practicable in most cases to isolate the tube from the rest of the chassis, because of the larger problem of heat dissipation. Possibly the best solution in these cases is the use of vibration isolators for the entire chassis or subchassis. When operating temperature is not too high for reliable operation, the tube and its socket sometimes can be independently isolated.

Fatigue vibration specified in MIL-E-1B is a 96-hour test at a frequency of 25 cycles and 2.5 g. Because the test is simpler to provide, 60 cycles and 2.5 g are often used.

At the conclusion of the test, some reduction in electrical performance is found, and the amount of change is controlled by specifying limits for selected characteristics after fatigue test. These characteristics are usually vibration noise, heater-to-cathode leakage, and transconductance. Fatigue test at levels higher than 2.5 g will accelerate deterioration of electrical performance. When made severe enough, the tubes can become useless in a matter of minutes.

The reduction in electrical performance is caused by the breaking of the mica around the tube parts and at the bulb contact points. The mount and its parts are thus held less rigidly, and more freedom exists for relative motion of parts. Consequently, noise increases in some tubes to a greater extent than in the majority of the group, and the tail of the vibration-noise distribution is increased.

The cathode may experience loss of minute particles of coating, in addition to becoming looser in its mica holes. The reduced mica contact results in less cathode cooling by the mica and a slightly higher cathode temperature at the ends of the cathode. In some tubes it is not unusual to find that transconductance has increased after vibration, while in others it has decreased. Characteristic changes caused by these mechanical alterations are controlled by the post-fatigue-test limits.

As a result of the MIL-E-1B fatigue test, there is some possibility of shorts between elements and of open welds. With the designs and manufacturing controls used in reliable tubes, these occur so rarely that they can be omitted as an effect of the specified fatigue test.

When vibration at resonant frequencies of the tube parts occurs for sustained periods, the damage to tube performance will be rapid in comparison to the specified fatigue test. The accelerations experienced by the tube parts can be many times greater than the applied acceleration and, from the reliability standpoint, may be disastrous. When the equipment is to be subjected to varying vibration frequencies, the designer should determine the frequency environment of the equipment, obtain from the tube manufacturer pertinent information, and, if necessary, eliminate the frequencies at which the tube will resonate.

## SHOCK PROBLEMS

Reliable-type tubes receive a mechanical shock test on the Navy High Impact Machine for Electronic Devices. The test is made on a sample from each production lot, and each tube receives five blows in each of four directions. Most testing is done at 500 g, and the time duration is approximately one millisecond, so that the shock is described as high-level long-duration. Tubes are permitted temporary instantaneous shorts and must pass electrical limits after the test.

There has been no general effort to increase shock ratings beyond 500 g. It appears that this level is sufficient for satisfactory performance and

few troublesome applications have been found. It is assumed that mechanical shocks, such as large-caliber gunfire, are usually not applied to the tubes directly, since they have some protection from the equipment case, and the shock wave transmitted through the chassis is damped to some extent at the tube base. The ability of a tube to withstand vibration has received much more attention than has shock resistance.

The tube design capable of good shock resistance should incorporate such mechanical characteristics that flexure of parts will be minimized. The reduction of these deflections aids in reducing vibration noise, also. Generally speaking, the smaller and shorter the parts, the greater the reduction in deflection when stressed, since length is the variable most affecting deflection. There is a region of interelement (spacings) to length ratios below which design should not go if it is to be satisfactory for a given shock level. In addition, part cross sections, such as grid spheroid diameters and cathode sleeve thickness, should be as large as practicable. In some instances, A-frames are used to increase tube mount rigidity.

Again, manufacturing controls must be complete, so that parts do not rupture, welds open, or loose particles, such as flaking cathode coating drift free to short between elements.

The severity of a shock impulse is related to the wave shape, the peak acceleration, and the total energy transferred. For the same frequency, components of the same wave shape and the same duration but differing peak accelerations, the energy delivered is dependent on the peak. The higher the peak, the more severe the shock. If the shock wave has large components of high frequencies, the damage to the tube will probably be less, because of the damping of those components by the time they reach the internal tube parts. If, on the other hand, high-energy, long-duration components of the wave are at the resonant frequency of certain tube parts, the effects will be most damaging. Tubes generally withstand long-duration shocks much better if the frequency is lower than the resonances.

## SHOCK CONTINUED

The mechanical deterioration of tube structures attributable to shock experience of the type exemplified by the MIL-E-1B shock test is, for the most part, not readily apparent. Inoperative failures happen much less frequently than was true early in the reliability program. Programs such as increased visual inspection of tube parts and the finished tube, plus the manufacturing controls contributing to mechanical uniformity, have reduced to a low order the frequency of occurrence of interelement shorts and open welds. Glass breakage is also much less frequent and, especially in miniatures and subminiatures, is sometimes caused by the increased glass strain applied by the clamping used in the shock test.

The common tube changes found after shock testing are electrical characteristic shifts. For example, the mica cross sections in contact with such tube elements as grid legs and cathodes experience

minute amounts of breakage and flaking. Hence, the parts are somewhat looser, and increased vibration noise can be expected. Mica breakage releases small quantities of gas, which are measurable as increases in control grid current. Also, the combination of increased freedom of part motion, which affects cathode temperature, with the small order of relative relocation of parts results in characteristic shifts, both up and down. Maximum  $S_m$  shift is of the order of 20 percent.

Most military applications do not require extensive shock isolation techniques, and normally, the methods of reducing vibration effects also contribute to shock reduction. In some particularly severe applications, emphasis may have to be placed on shock reduction, and this will probably be accomplished by modification of isolation methods. In some cases, consideration could be given to possible relocation of the equipment.

**Altitude Effects.** The problems encountered at altitude operation in tube applications center around bulb temperature, arc-over between external tube leads, and corona discharge.

Assuming the tube base is free of attached foreign material or surface deposits that can change the spacing or the electrical resistance between leads, the voltage necessary for breakdown will follow Paschen's law. This law will describe the minimum voltage for breakdown that will occur at a specific product of air pressure and pin spacing. Theoretically, this minimum voltage point can occur at an intermediate point between sea level and maximum altitude and, for specific mechanical designs, determines the maximum voltage that can be applied.

Reliable-tube specifications include an altitude test as a type approval test, and the user can feel confident that arc-over will not occur if the absolute maximum voltages are not exceeded. In the development of the tube and at type approval, maximum voltage operation is investigated and reliable performance verified. The maintenance of this dependability thereafter is a matter of quality of workmanship and cleanliness in connection with the external condition of the tube.

What has been said above is also directly applicable to corona discharge. However, in the application there may be an additional possibility of r-f corona, depending on the operating conditions and the type of connectors used at the tube. This problem is largely one of circuit design and component selection, and should be adequately tested in high r-f power areas.

Bulb temperature is the circuit designer's chief problem in designing for reliable high-altitude operation. Bulb temperature is actually the characteristic that must be minimized and controlled if a reduction in tube life, illustrated in "Effect of Temperature on Life," which occurs earlier in this chapter, is to be avoided. The absolute rating should not be exceeded; increased reliability may be attained if it is not approached.

Insufficient information is presently available on deratings for temperature and altitude, but when obtainable for specific types, it is most useful to the circuit designer.

The comments on cooling techniques described under "Effect of Temperature on Life" are applicable to the bulb temperature problems at high altitude. Cooling air quantities, however, can be reduced, because of reduced ambient temperatures in designs in which bulb temperature is controlled by conduction cooling techniques. Care should be exercised, nevertheless, in those cases in which bulb temperature does not have to be reduced by cooling techniques at sea level, but will rise under rarefied atmospheric conditions, possibly exceeding the absolute rating.

**Other Environments.** It can be expected that the problems due to humidity, salt spray, fungus, and sand will be relatively minor in comparison to the environmental problems discussed before. The materials used and the finishes applied are generally as resistant to the effects of the environments listed as any of the other equipment materials and components. Problems may arise when materials that differ from those used in general practice are used. However, the tube manufacturer tries to anticipate such possibilities and tests the changes, at least for humidity and salt spray effects.

Humidity and salt spray increase corrosion; glass, in unique cases, has been known to experience fungus attacks; and glass and other materials can be severely damaged by sandblasting. The effect of these conditions, however, should be no more troublesome than with other components, and not as troublesome as such circuit problems as leakage or shorts because of condensation, for example. Protective devices incorporated to reduce the equipment problems also serve to reduce the less important tube problems.

## PROPER AND IMPROPER WAYS TO USE TUBES

In the foregoing pages, an attempt has been made to acquaint the equipment designer with some of the problems faced by tube designers and manufacturers and to indicate and explain to the equipment designer some of the fine points of MIL-E-1B and other tube specifications.

In the following pages, some of the ways in which tubes can be (and have been) used, with a rather high probability of circuit and tube failure, will show the equipment designer techniques to avoid. These dangerous practices will be correlated to certain tube characteristics that are glossed over or omitted in school courses and texts on electronics, but which play a great part in most equipment in which tubes appear.

First, it must be appreciated that tubes, like anything else man-made, cannot be perfect. In fact, they are tremendously complex devices, often taken for granted, and often misunderstood and misapplied.

Manufacturers are continually striving to make better tubes. But once the tube has left the factory, the manufacturer loses all control over it. He can only hope that the ultimate user will not abuse it to the point where it fails and thereby endangers the equipment and the lives of men dependent upon the equipment.

Second, the equipment designer should remember that conservative principles of design must be used. A maximum allowable plate dissipation rating should be considered in the same light as the ultimate yield strength of a girder. In fact, that maximum rating should be looked at only as a good figure to divide by a healthy safety factor!

Some of the things bearing on tube safety factors and tube life, and often neglected entirely by designers, are grid current, contact potential, interelectrode leakage, gas current, and soon. These are discussed below, together with their effects on circuit operation.

Let us first admit that vacuum tubes are far from the idealized valves that have been considered in the classical courses on circuit design. Tubes have certain inherent detrimental properties that must be considered if any application is to be a success.

**Grid Current.** Even at the lowest of frequencies, the control grid of a negatively biased vacuum tube is not an infinite impedance device. A direct grid current quite often exists and, quite often, its effects may be disastrous.

Figure 8-20 shows something of the manner in which grid current behaves. These curves are broadly true for all receiving-type tubes in that they represent the general functional relationship. The initial velocity grid-current component as shown is fundamental to the emission process. It is due to the random distribution of velocities at which electrons leave the cathode surface. While a potential minimum is built up by the space charge between grid and cathode, this potential minimum assumes a value determined by the mean velocity. With a Maxwellian distribution of velocities, 50 percent of the electrons will have energies sufficient to pass through the space charge. Some of these will have insufficient energy to buck the retarding field at the grid and will fall back into the cloud, but a percentage of the faster electrons will strike the grid. The magnitude of the current thus generated will depend upon the surface area of the cathode, the projected area of the grid, the cathode temperature, and the instantaneous potential in the vicinity of the grid wires. The exact potential at which this initial-velocity current starts to flow is dependent on the "contact potential" at the grid.

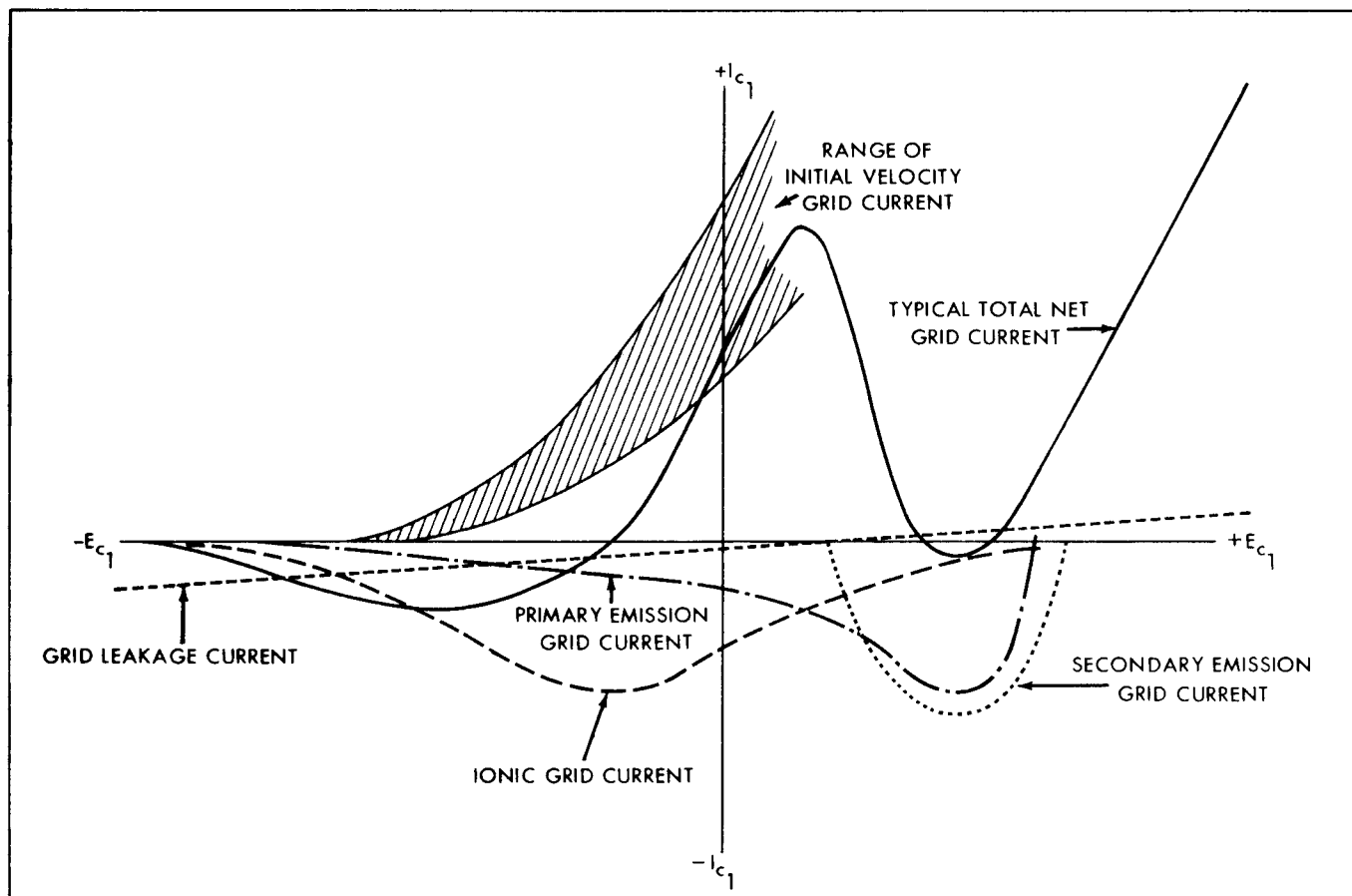

Figure 8-20. Grid current characteristics

Contact potential is rather difficult to define, because it means different things to different people. For the moment, assume that it arises from the same mechanism as having two dissimilar materials in contact at a high temperature. The contact potential at the grid surface varies throughout the life of the tube. The rate of variation is accelerated by higher heater voltages. The cause of this variation may be thought of as the result of the grid base material being slowly covered by free barium and strontium that have continuously evaporated from the cathode coating and condensed on the grid. The most commonly used measure of contact potential in the tube industry is the value of grid bias that must be used to reduce the grid current to 0.1 microamperes. From Figure 8-20, it is obvious that this arbitrary contact potential is not independent of contributions from gas currents, leakage currents, or emission currents existing in the tube under test.

Figure 8-21 shows the variation of initial velocity grid current with heater voltage. Scales have been used to indicate the expected order of magnitude of current and voltage, although considerable variation occurs with life. This is not "contact potential" as used in the tube industry, but is perhaps the largest component contributing to it.

The values shown are typical of receiving-type tubes using oxide-coated cathodes at a true temperature of about 825 C with tungstengrid laterals after perhaps fifty hours of life. This is quite a bit of qualification on Figure 8-22, but it is necessary, because contact potentials as high as 1.3 volts and as low as 0.1 volt have been observed. In general, the maximum variation to be expected during life is about 1 volt, although an average figure is about 0.4 volts, and the eventual stabilized value may be in the vicinity of 0.5 volts.

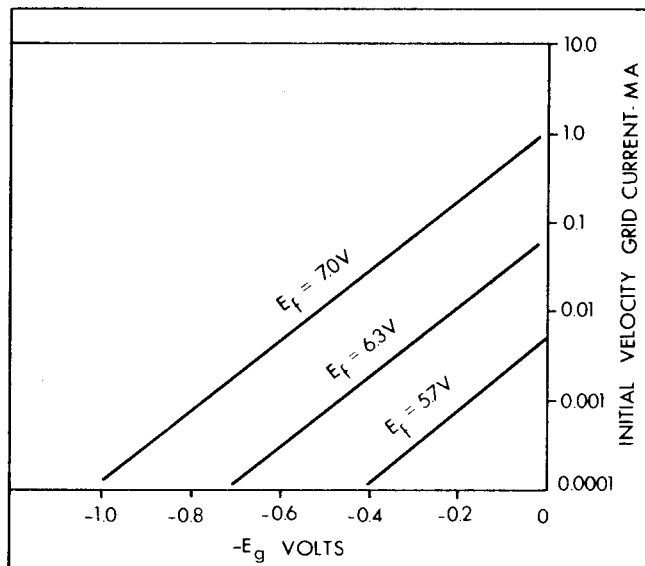

Figure 8-21. Initial velocity grid current component vs. grid voltage

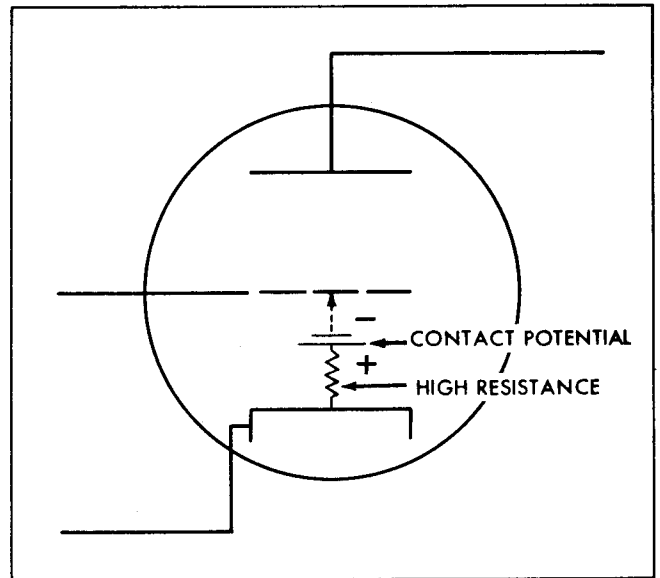

Figure 8-22. An equivalent circuit for contact potential

A change of one volt in grid potential can have effects of major proportions in circuits employing high- $\mu$  tubes, yet this change is certain. Very seldom will any data sheet or specification attempt to control contact potential; nor will the variation of contact potential with life be stated.

Yet, if a circuit that is stable in time and sensitive to an uncontrolled tube detriment is desired, the circuit must be designed to accept this inherent tube characteristic./11/

Contact-Potential Troubles. D-c feedback of the cathode resistor bias type is one way to overcome some of this trouble. Contact potential is essentially a bias battery in series with the grid, with the negative terminal on the grid and the positive terminal on the cathode, as pictured in Figure 8-22.

The design engineer will often choose a low value of cathode-bias resistor in order to operate the tube in a high transconductance region. From the standpoint of ordinary life considerations, this may be satisfactory; however, it is quite possible that the cathode self-bias voltage may be as low as one volt or less. Since the value of contact potential is of the same order of magnitude, the effective value of bias may be zero, or perhaps even positive. In any event, it is quite easy to end up in a region of grid current flow, producing a low input impedance to the grid, loading the input circuit, and reducing the circuit gain. The solution of this situation is simple: the bias resistance  $R_k$  must be increased. Of course, a reduction in  $S_m$  follows, but there is an increase of many times the net circuit gain, because of the reduction of circuit loading. The higher  $R_k$  may be made, and the higher the operating bias, the less important the change of contact potential becomes. First, because of the self-stabilizing feature of  $R_k$  as a feedback device, a reduction in contact potential raises



the effective bias, causing the current through  $R_k$  to decrease, which again reduces the effective bias and stabilizes at some new point. The amount of change is, however, somewhat compressed from that which would occur with fixed bias. Second, the higher values of  $R_k$  mean higher bias, and the contact-potential variable part is now a smaller percentage of the total bias.

A circuit that allows a considerable increase in  $R_k$  for stabilization purposes, but which does not sacrifice  $S_m$  through excessive bias, is shown in Figure 8-23.  $R_k$  in this case is abnormally high — about 10 times higher than normally used.

Voltage across  $R_k$  may be as high as desired, perhaps even exceeding cutoff of the tube. A stable fixed bias in the positive direction is used to buck out all but the effective value required of the cathode bias. The effect of feedback stabilization may be increased many times by the use of this feature.

Contact potential is also a function of heater voltage (cathode temperature). Therefore, heater-voltage regulation serves the function of reducing variations from this cause, as well as aiding in the reduction of heater burnouts.

A useful circuit trick that can be used when it is imperative that contact potential variations of a critical tube be minimized is shown in Figure 8-24. A tube identical in type and past history to the critical tube is diode-connected in series with the grid of the critical tube in such a manner that its contact potential is equal and opposite to that of the working tube. As both tubes will change in the same direction with life, the net effect on the circuit is reduced.

**Gas Current.** Another grid current component of importance in practical design is ionic grid current, quite often called simply "gas" current by tube engineers. It arises from the ionization of gas molecules by the flow of electron current in the

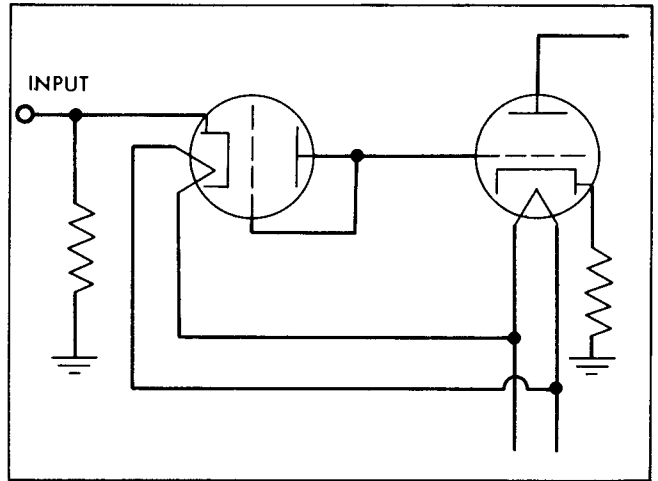

Figure 8-24. Circuit using tubes varying in opposite directions to compensate for effects of contact potential

tube. It is a function of the magnitude of the space current (screen-plate total) and of the density of the gas present. Almost everything that goes into the makeup of a tube may be a source of gas, but overheating of the larger metal parts is perhaps the most common one.

Oxide-coated cathodes used in the largest single category of vacuum tubes depend for their emission on the existence of some free barium at the cathode surface. This free barium must continually replenish itself through breakdown of the oxide coating and the release of oxygen. Therefore, some measure of gas is a necessary condition to the use of oxide coated cathodes.

Included in the tube is an active metal, such as barium or magnesium, as a "gettering" element, which absorbs gas as an aid in maintaining the vacuum. If the operation of the tube is conservative, and if parts do not get too hot, a gradual reduction of "gas" current occurs as the tube ages. However, if a tube is pushed a little, or if several maximum ratings are achieved at once, or if the environment is just a little too hot, or even if vibration is severe enough to cause flaking of the mica, gas may be produced at a rate faster than the getter can handle. In an application with a low d-c impedance grid circuit, this means grid current, a-c loading, and perhaps reduced gain. These effects are serious enough in themselves, but not necessarily catastrophic.

A similar situation in a high d-c impedance grid circuit is shown in Figure 8-25. Here,  $R_g$  may have a value in the megohm region, perhaps 10 megohms.  $R_k$  is sufficient to give perhaps two volts of bias. Ionic gas current flows, that is, positive ions from the gas go to the negative grid through  $R_g$  to the cathode. The voltage drop across  $R_g$  is in such a direction that the grid picks up a positive bias, which may override the cathode bias completely. In any event, the more positive grid causes a higher space current, which in turn causes more ionization, which

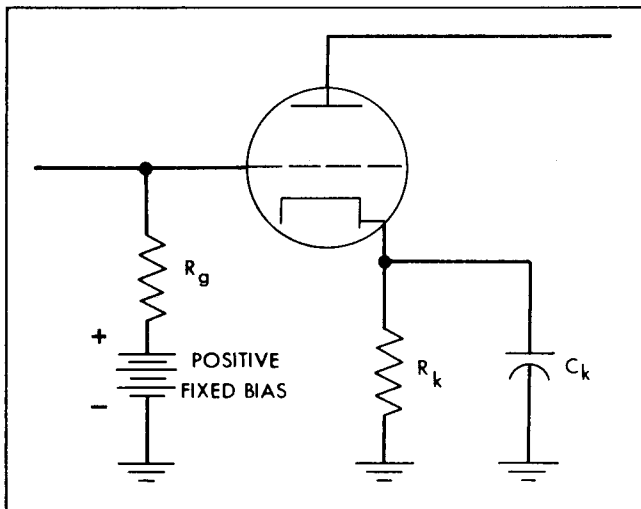

Figure 8-23. Circuit using abnormally high value of  $R_k$  to decrease effects of contact potential

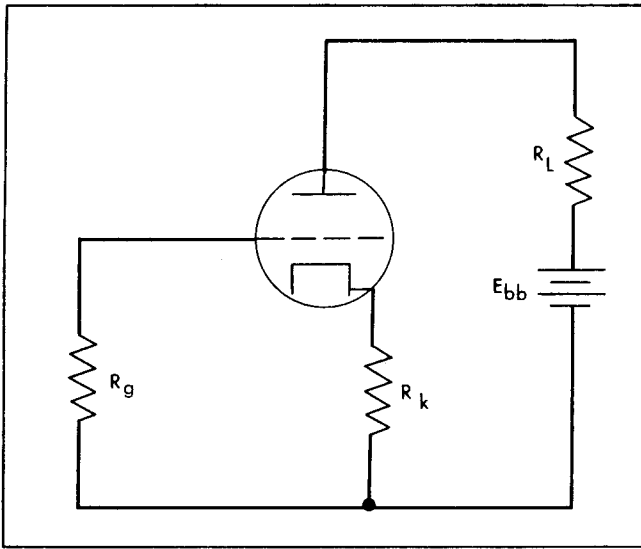

Figure 8-25. Circuit using a high value of d-c grid impedance that maximizes the effects of gas currents

causes more gas current, which causes more positive bias. The total action is cumulative, and the tube eventually destroys itself. With grid connected to ground through several megohms, this action may start with microamperes of grid current. One sure cure is absolutely gas-free tubes, but these cannot be made as yet. A more realistic approach is that of following the manufacturer's recommendation on maximum grid-circuit resistance. The values recommended (which very rarely exceed one megohm) are found to have been safe over a fairly wide experience under typical operating conditions. If a circuit will work with a lower value of grid leak resistance, by all means use it. If it seems necessary to work a tube near its upper power, voltage, or current limits, then by all means reduce the manufacturer's maximum grid resistance recommendation by as much as is tolerable. A reduction by a factor of four provides safety in many applications.

This point cannot be stressed too much. If all circuit designers were to divide by a factor of two the grid circuit resistance they would normally arrive at, a major contribution to improved reliability would result. This grid circuit resistance shows up again when we consider leakage, and again when grid emission is considered. It is important, and should never be overlooked.

Floating Grids. From time to time, applications have turned up in which tubes are used with open grids and essentially infinite d-c resistance in the grid return; surprisingly enough, they have been both satisfactory and stable. The method is essentially that of 100 percent feedback and the circuits have been impedance transformers rather than gain circuits. One circuit, in particular, matched an extremely high-impedance capacitance microphone to a preamplifier. This sort of thing is tightrope walking. It has been done successfully, but it requires

a thorough knowledge of tube grid peculiarities. This dangerous technique is not recommended.

Grid Circuit Leakage. In many applications, it is important that some thought be given to make certain that all circuit impedances are small compared to the manufacturer's low limit on interelectrode leakage resistance.

In a well-designed and carefully processed tube, these leakage resistances may well exceed thousands of megohms, and usually do. However, it is quite possible for cathode nickel to be evaporated from the cathode sleeve and condense out on the cooler mica insulators. This sort of evaporation may result from the initial high cathode temperature employed to break down the carbonate coating in producing the activated oxide-coated cathode. For this reason, the tube manufacturer places a lower limit on the value of acceptable leakage resistance and rejects tubes below this limit. This limit is more or less determined by the temperature-vs.-time aging schedule needed to activate the cathode, which determines the evaporation, which in turn determines the leakage. A rough coating material is usually used on the micas, and slots are quite often cut in the mica to increase the length of the leakage path. Finally, a leakage specification is determined by the economics of how many tubes the manufacturer can throw away at a given price. Research continues on new cathode materials, different activation schedules, and so on in a long-term project to improve this particular situation.

In making the ruggedized- and reliable-tube types, sufficient care is exercised to ensure that the mean value, say of grid-to-plate leakage resistance, exceeds 1,000 megohms. Inasmuch as the process of producing emission from an oxide coated cathode is still something of an art, the tube engineer must be allowed a certain amount of latitude in his activation schedules. This in turn affects the leakage, and, therefore, some variation does exist from lot to lot. For this reason, it is usual to set the leakage resistance limit some distance below the mean.

For many tubes in the "reliable" line, this limit is 100 megohms initially, and after continued operation for perhaps 1,000 hours, the end-of-life point may be set at 50 megohms. Interelement leakage resistance is often subject to very wide fluctuations arising from changes in contact between the elements and the mica, but in general, the value of the resistance becomes progressively lower with life.

Now, in general, values of impedances of 50 or 100 megohms and higher would have little effect on many vacuum tube circuits. But in circuits using high grid-circuit resistance, problems can arise. One may think that 10 megohms would make only a 10 percent difference. Figure 8-26 will explain why this is an error.

The divider action

$$\frac{R_g}{R_{Lgp} + R_g} \times E_p$$

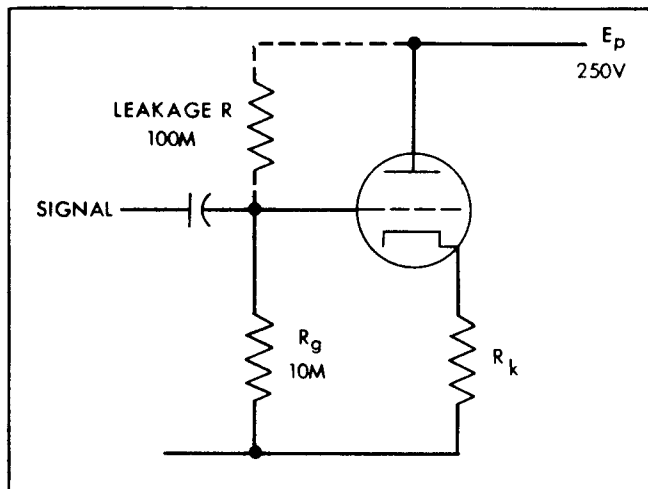

Figure 8-26. Circuit illustrating voltage divider action of grid-to-plate leakage resistance and grid leak resistor

gives a positive grid voltage. This causes grid current to flow, as well as an increase in plate current. In a severe case, the grid would essentially be clamped to the cathode potential as though tied to it by a 1,000-ohm resistor. The plate current would be approximately that of the zero-bias condition, and the input impedance would be so low as to make driving the stage practically impossible. If this were a cathode follower with high  $R_k$ , the operating conditions from tube to tube would change greatly, because leakage is controlled only for a low limit, and considerable variation can be expected from tube to tube above this limit.

The example just shown is not exaggerated. One of the most respected laboratories had trouble traced by the designer to lack of uniformity of tubes of a certain type. Questioning brought out the circuit just shown. The MIL-E-1B specification on grid-plate leakage on this type was 100 megohms as a lower limit. When this fact was pointed out, the difficulty became obvious.

Interelement leakage resistances are most troublesome in the grid circuit in normal amplifier applications, but in special applications, plate- or heater-cathode leakage may be troublesome. The cure is always the same — reduce the circuit impedance level until the leakage values are of no effect. This will sacrifice some performance, but in many cases where a single close-spaced, high-performance tube is subject to grid emission, gas current, contact potential variation, interelement leakage, and the like, the obvious solution for reliability is to use two ordinary tubes. Two tubes can perform more reliably than one, because they can operate at normal levels and not be pushed to maximum values.

"Such a practice of using more tubes than the minimum in a conservative manner to accomplish a purpose may be objectionable to many equipment

designers who can cite weight or size requirements as making such a practice impossible. If so, we can only state that the equipment designer himself is undertaking the impossible, for by not being conservative in accordance with clear-cut engineering formulae and data, he must of a certainty fail." /7/

Close-spaced, high-performance tubes are more subject to wider initial tolerances, greater changes with life, more difficulties with leakage, gas, grid emission, and most of the other problems in uncontrolled detrimental properties that beset the tube industry. They are also more susceptible to microphonics, impact shock damage, and vibration fatigue. Used wisely in the relatively low-impedance, high-frequency applications for which they are designed, these tubes are an important asset to the equipment designer's bag of tricks. A close-spaced, high figure-of-merit tube should only be used where no other alternative exists. The two types (6AK5 and 6J6) that head the ARINC list of tube failures are close-spaced, high-performance types. /12/

Heater-Cathode Leakage. Some of the considerations that the tube manufacturer must face in heater design should be of interest to circuit engineers because they influence circuit operation. In general, heaters are made of tungsten wire insulated by a coating of aluminum oxide or similar refractory material. To get sufficient heat within the cathode, this wire is formed into a double helix, a single coil, or perhaps a coiled coil, or very often is merely folded back and forth a number of times. The size of the cathode is quite often controlled by plate current or input capacitance requirements, and very little space is allowed for heaters. A problem may arise in getting sufficient heat into the cathode. Sometimes, very little room remains for insulation. However, even if considerable cathode size is available, thick insulation reduces the amount of heat that can be transferred rapidly to the cathode. Increased heater current will help this, but that means lower resistance, larger diameter wire, which reduces available room for insulation, and, again, reduced thickness of insulation. A balance must be struck between heater warmup time, required heater power, maximum heater wire temperature, and heater-cathode insulation. Very often, this results in compromising a little on all counts.

Tungsten heater wire has a hot-to-cold resistance change of about 7 to 1, indicating a relatively high expansion. Refractory materials, such as aluminum oxide, have a considerably different expansion rate. Therefore, considerable mechanical stress can be set up in the insulating coating. In addition, the expansion and contraction during on-off cycling of the heater causes mechanical abrasion between adjacent wires and against the inside of the cathode sleeve. Environmental vibration may have a similar effect. These mechanical considerations can result in electrical breakdown of the insulating material. Abnormally high surges of heater current, such as are encountered in the use of poorly matched heaters in a series string, can aggravate this condition. The reliable lines of tubes now being produced are controlled by MIL-E-1B specification so that 2,500 on-off cycles

may be expected under conditions of 10 percent heater overvoltage. No control is placed on heater cathode leakage during this test other than a 140-volt rms a-c voltage from a low-impedance source being connected between heater and cathode. If a low-impedance short should develop, this would cause heater burnout and constitute a failure. This test subjects the heater to short bursts of starting currents of about 8 times normal operating currents. Situations many times worse than this may occur in series-string arrangements if the thermal inertias of the various heaters are not matched. It is expected that such conditions will have considerable effect on the heater-cathode insulation. Thermal efficiency considerations have decreed an insulation thickness of perhaps a few thousandths of an inch; the mechanical effects of operation subject this coating to considerable abuse. Is it any wonder, then, that the tube manufacturers like to place an electrical limitation on the maximum voltage stress that the circuit designer may employ? With a heater-cathode voltage limitation of  $\pm 100$  volts, it is not unusual to achieve potential gradients in excess of 20 Kv per inch. Tube manufacturers feel that the low order of leakage (a few microamperes) maintained under these conditions represents an achievement of considerable magnitude. Heater-cathode leakage fluctuates with time because of the constantly changing leakage paths resulting from the stresses of on-off heater cycling. Heater-cathode leakage is not strictly ohmic in nature because the insulating material acts as a semiconductor at high temperatures. The general nature of the E - I curve is shown in Figure 8-27.

In considering the circuit effects of heater-cathode leakage, it is apparent that no problem exists in those circuits that tie the cathode and heater to the same potential. It is likewise obvious that cathode bias of low impedance at the heater frequency will be relatively free of hum problems. Where it is necessary to use relatively high values of unbypassed cathode resistance, it is sometimes advisable to apply a heater cathode bias, as shown at  $-V$  in Figure

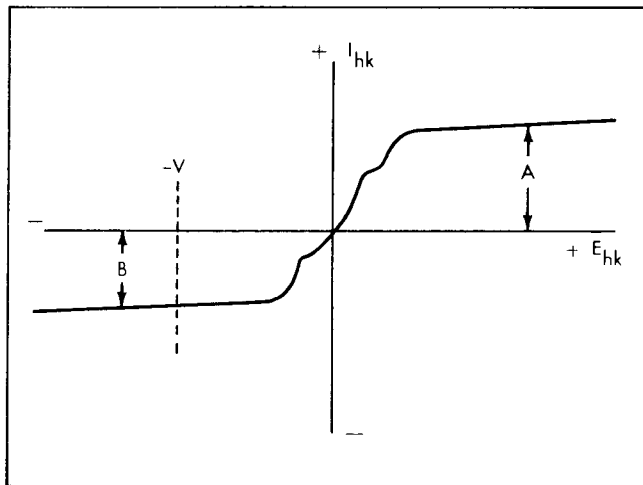

Figure 8-27. Heater-to-cathode leakage current vs. voltage

8-27. This does not eliminate the leakage but ensures that the value of  $I_{hk}$  will remain relatively constant as the signal voltage on the cathode changes. This has two beneficial effects. First, it prevents the non-linear combination of the signal and hum from producing sum-and-difference frequencies, which might pass through amplifiers that normally reject hum frequencies, and, second, in low-frequency and direct-coupled amplifiers which do pass hum frequency, it controls the introduced hum to a fixed level, so that it may be bucked out somewhere else in the circuit.

Heater-cathode leakage current is a vacuum tube detriment that is under a single limit control, as specified for the particular type tube in the MIL-E-1B specifications. In general, the limit specified is not to be taken as typical for the type, because the distribution is as shown in Figure 8-28.

It would be a wise precaution to simulate leakage in all circuits using a potential difference between heater and cathode, with adding resistors to observe the overall effect on the system.

Grid Emission. When a tube engineer has finished his job, the quality control department has given its blessing, and the little green boxes are stacked in the warehouse, we are all fairly certain that the lot will meet every specification on the sheet. But there are really a great many things we still don't know about the lot — things of interest to perhaps one customer in a hundred and, therefore, not on the specification. Each user of a given type may have special applications for which he would like tight production control on some special tube characteristic. In total, these tests would perhaps triple the testing on each type. The testing costs would go up and the total tube yield would go down. The net increase in tube costs may be as much as thirty times. Perhaps cost may not really count in an emergency situation, but the reduction of tube yield would not be tolerable in the light of wasted manpower. Grid emission is one of the inherent tube characteristics that falls in this category.

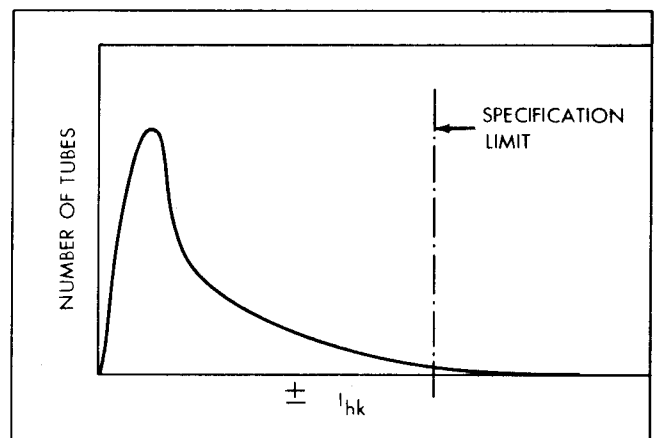

Figure 8-28. Typical distribution of heater-to-cathode leakage current variations among various tubes

Most electrode materials are capable of some emission. The actual magnitude of the currents emitted are functions of electrode temperature, material work function, and voltage gradient. Consider only the control grid for the moment. It has previously been mentioned that barium evaporates from the cathode during processing and tube life. The control grid is close to the cathode and is at a somewhat lower temperature. Barium, therefore, may condense on the grid wires. The grid is cooler than the cathode, but it is still rather hot. In many instances, enough barium may be deposited so that, in combination with high grid temperature, the control grid becomes a source of primary emission. The level of emission will never approach that of the cathode, but a flow of electrons from the negative control grid to other more positive electrodes must result in a current through the external grid circuit. This results in a loss of grid bias, with consequent change in circuit operation as the emission develops. In severe cases, the bias reduction may cause a regenerative action, plate current runaway, and, eventually, gas arcs, with total destruction of the tube. Tube manufacturers have learned that base materials underlying the barium oxide coatings have considerable effect on emission. Thus, one of the methods of combatting grid emission has been that of selecting a poor cathode base material for use in grids, so that although coated with evaporated barium, the emission is suppressed. However, when dealing with the grid structures of conventionally-made tubes using wound grids, the only grid lateral material of sufficient strength is tungsten. Our base material is thus decided for us, and the next most obvious approach is to plate the tungsten with an emission-suppressing material. Gold plating has been used quite frequently and seems to have a beneficial effect.

Grid emission is a problem that has substantially been cured for small-signal, negative-grid operation of receiving tubes. However, in those applications where positive grid current flows during a portion of the cycle (such as class C oscillators, pulse circuits, sweep amplifiers, and so on), it is comparatively easy to raise the control grid temperature into the emitting region. The heat dissipation capabilities of a control grid wound with 0.001-inch diameter wire located 0.003 inch from a cathode at 800 C are not great. Maximum allowable heat dissipation would be a difficult value to establish and would be equally difficult for the circuit designer to use. For this reason, it is common practice on many tube types to specify a maximum allowable value of positive grid current in lieu of a grid dissipation rating. On most tube types, no specification control is exercised for grid emission as such. Some grid-current tests at elevated heater voltage have been devised to assure a reduced tendency for primary grid emission, but from a review of the considerations of gas, leakage, and initial velocity (contact potential) components of grid current, it can be seen that the interpretation of such a test is like solving a single equation of four unknowns.

Grid emission is an unknown quantity in most tubes, in most applications. It can exhibit wide variations from tube to tube. In special tests conducted

to simulate severe class C operation, currents in excess of 40 microamperes have been observed. The circuit designer's obvious approach to this problem should be to reduce the d-c grid-circuit resistance.

R<sub>g</sub> Must Be Kept Low. Grid emission is not something a circuit designer usually encounters. It is a slow-growing, insidious sort of thing, which all too often never appears during development, and then shows up as a plague when the equipment is in service.

Secondary Grid Emission. This situation would be bad enough, but there is another form of grid emission that sometimes appears to complicate the circuit problem further. This is secondary grid emission, which may occur when the grid is driven positive during part of the cycle. During this time of positive voltage, the grid attracts electrons, and the electron bombardment of the barium-coated grid laterals results in the emission of secondary electrons. This emission current during a fraction of a cycle is in opposition to the normal grid flow and has the net result of making the tube easier to drive. If the driver amplifier requirements are based on a tube lot that had secondary grid emission, sufficient drive would not be available when more normal tubes were used. In general, there is no specification of receiving types, or even low power transmitting tubes, that mentions control grid secondary emission.

Secondary emission in a receiving tube is just an "accident"; it wasn't put there, it happened. It is not under control. No two tubes can be expected to be alike in this respect. There is no guarantee that it will remain stable with time or with operating conditions. And it places a rather severe limitation on the maximum drive the grid will accept. /13/

The curve of Figure 8-29 shows grid current vs. grid voltage in the positive grid region for a tube with appreciable secondary emission. If the grid drive should be sufficient to drive the grid voltage positive beyond point A, then the negative grid current through the positive resistance of R<sub>g</sub> would result in sufficient positive voltage being developed in R<sub>g</sub> to sustain operation at point A. Thus, the tube may block at +50 volts on the grid and stay there until the tube is destroyed. But, if R<sub>g</sub> is of such low value that the slope of the load line cannot intersect the grid characteristic, this trouble cannot arise. The answer to this kind of trouble is: use low values of R<sub>g</sub>. All this costs is a little gain, a little sensitivity, a little power (and not much of that). Table 8-4 shows that reducing the grid resistance by a factor of 4 (from 1 megohm to 0.27 megohm) reduces the gain only 13 percent. The stability, however, would be much greater.

Servomotor Troubles. A recent application of triodes is that of controlling servomotors. In these circuits, raw ac is applied to the plate of the tube, so that the condition in which the grid is not the most negative element may arise. Thus, during the inverse peak of the plate voltage swing, the plate may emit electrons to the grid. The effect of such

Table 8-4

Resistance coupled amplifier data 12AT6

Self-bias operation

E <sub>bb</sub> = 100 volts							
R <sub>p</sub>	0.1		0.27		0.47		
R <sub>g</sub>	0.27	0.47	0.27	0.47	1.0	0.47	1.0
R <sub>k</sub>	3300	3300	5600	5600	6800	8200	10,000
I <sub>b</sub>	0.288	0.288	0.161	0.161	0.146	0.108	0.099
E <sub>c</sub>	0.95	0.95	0.9	0.9	0.99	0.89	0.99
E <sub>b</sub>	71.2	71.2	56.5	56.5	60.6	49.2	53.5
E <sub>sig</sub>	0.1	0.1	0.1	0.1	0.1	0.1	0.1
E <sub>out</sub>	3.53	3.82	4.1	4.53	4.73	4.63	4.9
Gain	35.3	38.2	41.0	45.3	47.3	46.3	49.0
% Dist	0.55	0.9	1.6	1.2	1.1	1.5	1.2

current is similar to initial-velocity currents discussed earlier. However, this plate emission is modulated at the supply frequency and is dependent upon the level of plate dissipation. It is also subject to considerable drift during life. Emission to the grid is not a common trouble, but if in a triode application the plate swings as much as 100 volts negative, then trouble may be experienced.

**Interface Effects.** During the war, considerable difficulty arose in low duty-cycle (high peak-current) pulse circuits. Tubes seemed to fail faster when not actually working, or when working lightly, than they did under normal steady-state current conditions. Failure of this type is due to the formation of a resistance layer at the interface between the metallic cathode sleeve and the barium oxide emission coating. The manifestation in a circuit is as though an unbypassed resistance were inserted in the cathode circuit. The resulting negative feedback reduces the effective S<sub>m</sub> and, therefore, the circuit gain. Premature failure to meet electrical specifications is the end result.

The formation is greatly accelerated by high cathode temperatures and by conditions of little or no cathode current. Once formed, the process is not reversible. Normal plate current flow will retard the formation initially, but after the interface resistance is formed, it cannot be eliminated.

Figure 8-30 shows the effect of the growth of interface resistance with life.

This is typical of conventional tubes in which no special attempt has been made to alleviate this difficulty. However, there are now available tubes

that use a special low-silicon cathode nickel material that minimizes interface resistance. The type 5693 is one tube specifically designed for low interface formation. Interface formation with the type 12AU7 is very much less than for the 12SN7. In addition, the variation from lot to lot is very much less for the 12AU7 than for the 12SN7. In general, there is no specification control for interface resistance, but the MIL-E-1B end-of-life limits for S<sub>m</sub> at reduced heater voltage does exercise some control. Interface formation is properly a matter for the tube manufacturers to correct, but the circuit designer can further minimize the effects by operating tubes at rated heater voltage. Perhaps heater voltage regulation is justified in critical applications. Interface resistance is not a

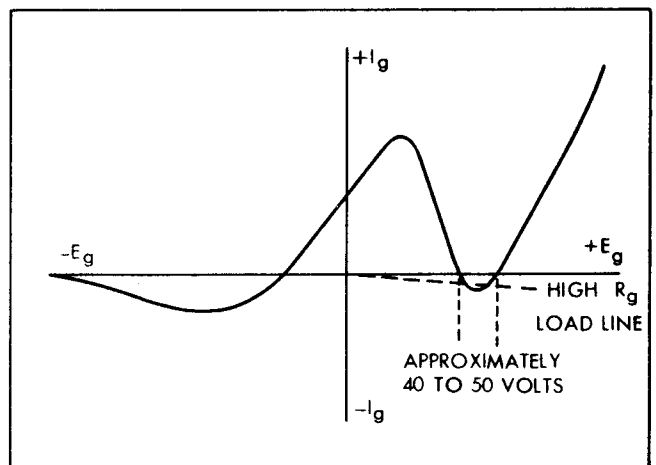

Figure 8-29. Typical curve of total grid current

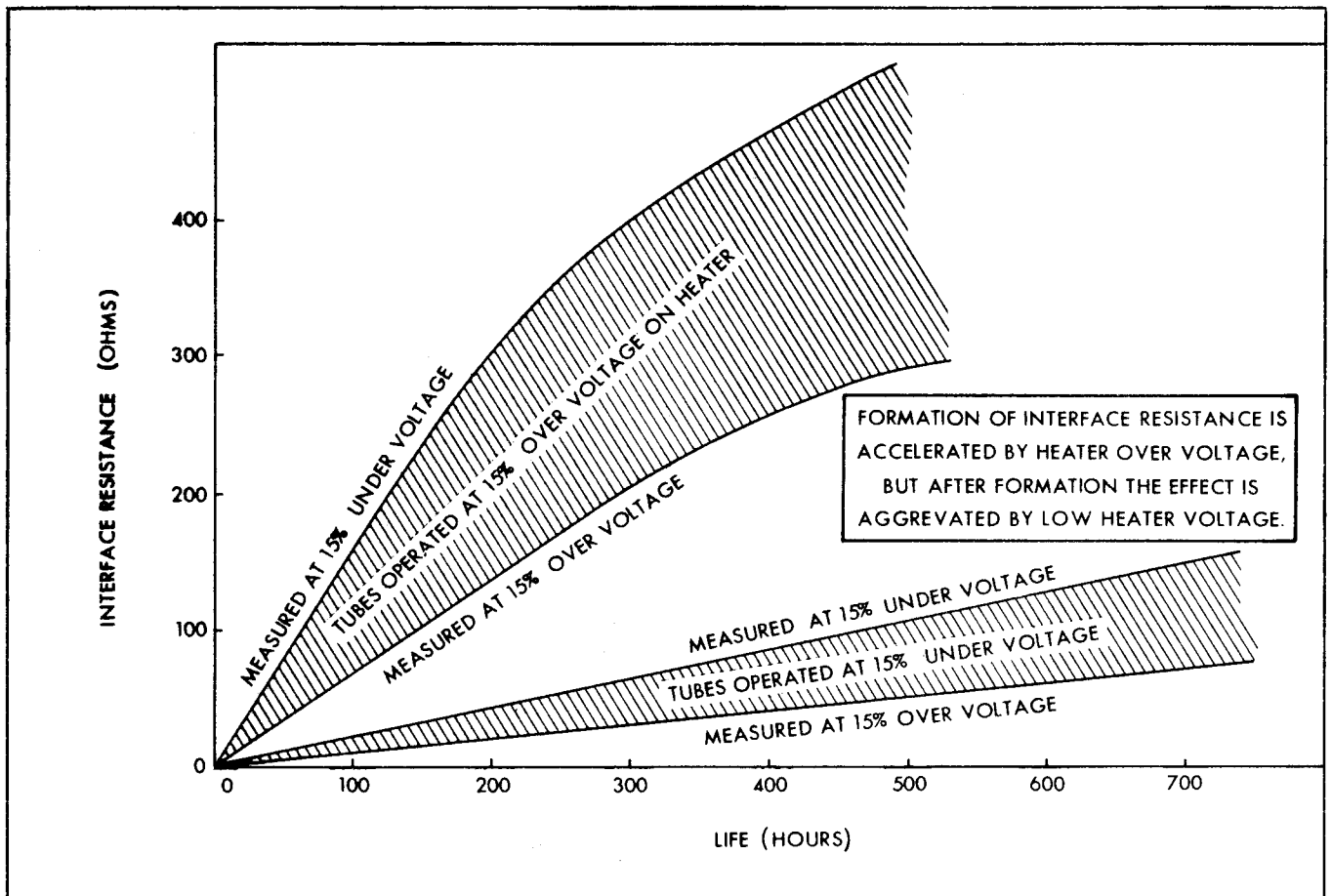

Figure 8-30. Formation of cathode interface resistance as a function of life

problem in many applications, and for this application, tube manufacturers can supply better all-round tubes if the active cathode nickel alloys are used.

#### ULTRA-HIGH-FREQUENCY EFFECTS

In general, all of the foregoing tube troubles, with the possible exception of interface resistance, seem to exist at all parts of the radio-frequency spectrum. However, there are additional uncontrolled tube characteristics that play an important part in tube behavior at very high frequencies.

Input Resistance. At very high frequencies, a point is reached beyond which the velocity of electron motion in the tube becomes important and can no longer be considered infinite. When the time of transit of electrons from cathode to grid becomes an appreciable portion of the period of the signal voltage, electrons leaving the cathode during a time of positive voltage gradient may fail to reach the grid plane before the grid voltage reverses. Thus, the time of maximum grid voltage and the time of maximum charge passing the grid are not coincident. The derivative of induced grid change is grid current, and it likewise is not of coincident phase with the driving voltage. The net effect is that the input signal must supply power. For purposes of a high-frequency equivalent circuit, this power is considered to be dissipated in an "input resistance," which is shown as shunting the grid input. This component of  $R_{in}$  may be expressed as

$$R_{in} = \frac{1}{K_1 T_g f^2 S_m} \text{ (from D. O. North)}$$

$$K_1 = \frac{4\pi^2}{180} \left[ 9 + \frac{T_\rho}{T_g} + 45 \left( \frac{T_\rho}{T_g} \right)^2 \dots \right]$$

where

$T_g$  = time of transit in grid cathode region  
 $T_\rho$  = time of transit in grid plate region  
 $f$  = frequency in cycles

Where the a-c plate current of the high frequency tube flows through an inductive cathode circuit common to the input of the tube, there may be generated an additional component of "input resistance" that is of equal importance in producing the total input loss. This component is expressed by

$$R_{in2} = \frac{1}{K_2 f^2 L_k C_{gk} S_m}$$

where  $K_2$  = cathode lead inductance common to input and output of tube

$C_{gk}$  = grid-to-cathode capacitance at the internal tube structure

Inasmuch as both effects vary inversely with  $S_m$  and inversely as the square of the frequency, it is usual

to lump them into one figure, called input resistance. Some data on typical values for several high frequency types are shown in Figure 8-31.

The solid lines of Figure 8-31 show the actual value of loading resistance appearing at the tube structure and, therefore, the value of interest in determining circuit gain. However, a very different value may be measured at the tube terminals. The self-inductance of the tube pins and internal tube connections has sufficient effect to transform a fairly high resistance inside the tube to something very much different at the external terminals, if the frequency is high. This effect is shown by the dotted curves of Figure 8-31, which represent values of input resistance measured at the tube terminals. The input resistance of triodes is very dependent upon the plate load impedance, and, therefore, no triode curves are shown. In grounded grid triode mixers, other considerations than electron transit time determine the input loading.

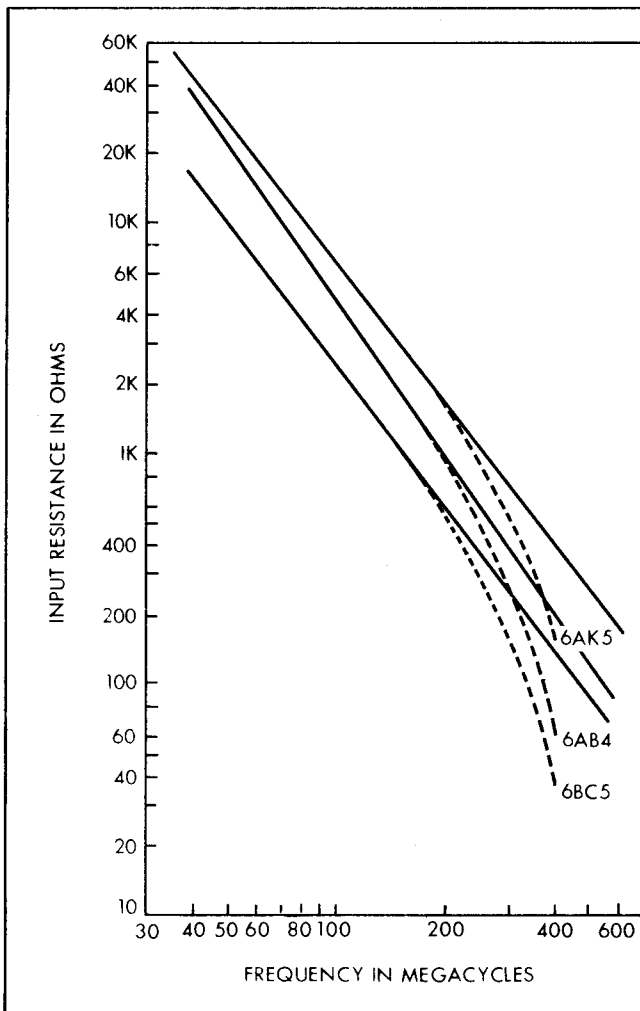

Figure 8-31. Effects of variation of frequencies on input impedances

It would seem reasonable that if plate loading impedance influences input losses of triodes, then screen bypassing would influence the input losses of pentodes. This has been found to be the case. Figure 8-32 shows the variation of input resistance for the 6AK5 as a function of unbypassed screen lead length at 100 megacycles. The lead measurement was taken from the center of the screen structure to the ground point of the cathode return.

The increased values of input resistance achievable with a little unbypassed screen inductance are not necessarily advantageous, because they are accomplished at the sacrifice of feedback impedance. This trick is worthy of consideration only in those cases where the added inductance is appreciable at the input frequency, but negligible at the output frequency. In essence, this means mixers only.

In those applications of high frequency amplifier tubes that require avc bias, a considerable detuning may occur because of Miller effect. /15/ The curves of Figures 8-33 and 8-34 show the reactive-resistive components of input impedance as functions of bias at two different frequencies for a typical v-h-f amplifier pentode (Premium Subminiature type 5840). The Miller effect is shown by the uncompensated curve. The effect of negative feedback from an unbypassed cathode resistor of suitable value is shown for two frequencies. The use of this type of feedback has a compensating effect on input impedance. /16/

In all these considerations of input resistance, we are presuming that input losses occur in some rather hypothetical input "resistance." Actually, the power going into the grid pin is anything but hypothetical, and it must show up somewhere as heat. Some of this power is dissipated as heat at the grid, but a very appreciable amount is absorbed in turning back those electrons that leave the cathode too late in the cycle to pass the grid before the signal reverses.

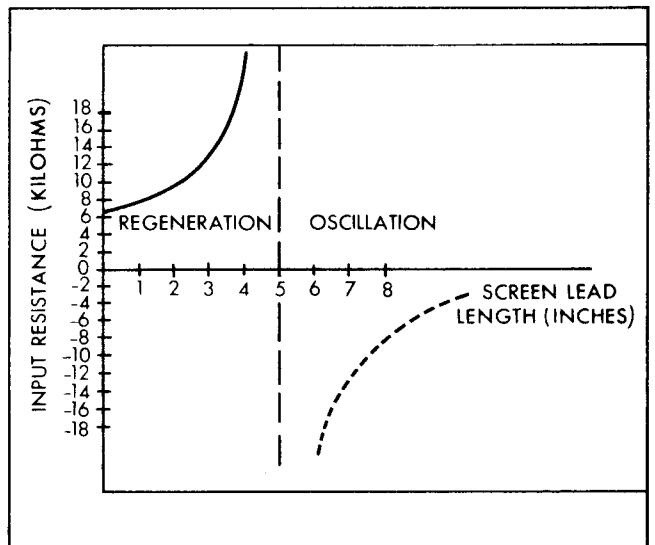

Figure 8-32. Variation of input resistance of pentodes as a function of unbypassed screen loading at 100 Mc



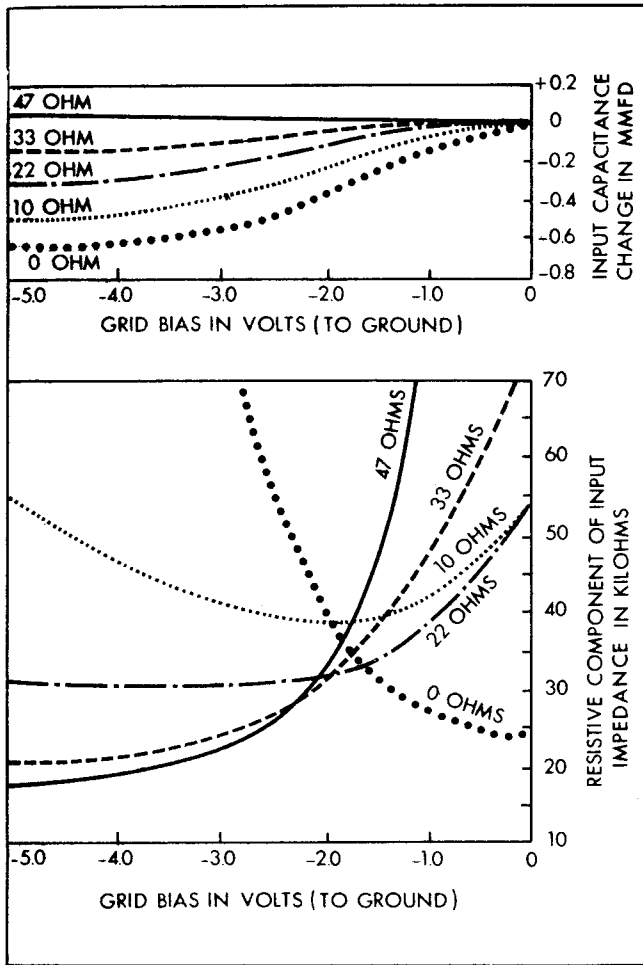

Figure 8-33. Reactive and resistive components of input impedance at 60 Mc

These electrons return to the cathode with more energy than when they left, and thus succeed in raising the cathode temperature by electron bombardment. This cathode back-heating can be quite important in low-power local oscillators at v-h-f, where its major effect is to cause drift of operating characteristics for a considerable time after the plate voltage is switched on. In addition, if the increase in cathode temperature is sufficient, it will shorten tube life seriously.

In general, it seems that the requirements of small size, close spacing, high  $S_m$  per milliampere of plate current, high current per square centimeter of cathode area, and low internal capacitance, which are basic to satisfactory high-frequency performance, are exactly contrary to the needs for reliability. It is in these close-spaced, high-performance tubes designed for high-frequency use that the greatest need for improvement is evident.

Several developmental projects aimed at improving this situation are underway, so that some hope can be held out for improved reliability of v-h-f types in the future. At the present time, however,

the approach must be to take as many precautions as are available. The addition of circuit test points to allow a rapid check of tube operation is one technique; self-bias circuits or other forms of d-c feedback external to the r-f circuit is another technique that may have considerable stabilizing effect on tube characteristics and v-h-f performance.

Feedback Stabilization Possibilities. Some appreciation of the degree of stabilization possible may be conveyed by the following examples. Figure 8-35 shows transfer characteristics for tubes representing the maximum and minimum limits of plate current as specified under MIL-E-1B for a typical medium- $\mu$  triode. Under rated conditions of  $E_b = 250$ ,  $E_{c1} = -8.5$ , a bogey tube (average tube) would draw 10.5 milliamperes  $I_b$ . The allowable spread of  $\pm 4$  milliamperes is due to manufacturing tolerances, and at one time or another, all of this spread will be used. However, if the -8.5-volt bias at 10.5-milliamperere average plate current is produced by an 810-ohm cathode resistor, the operation of the bogey tube is unchanged. At the conditions set up by limit tubes in such a feedback circuit, the plate currents would be between 8.7 and 11.8 milliamperes, thus giving a new range of plate current of only +1.3 and

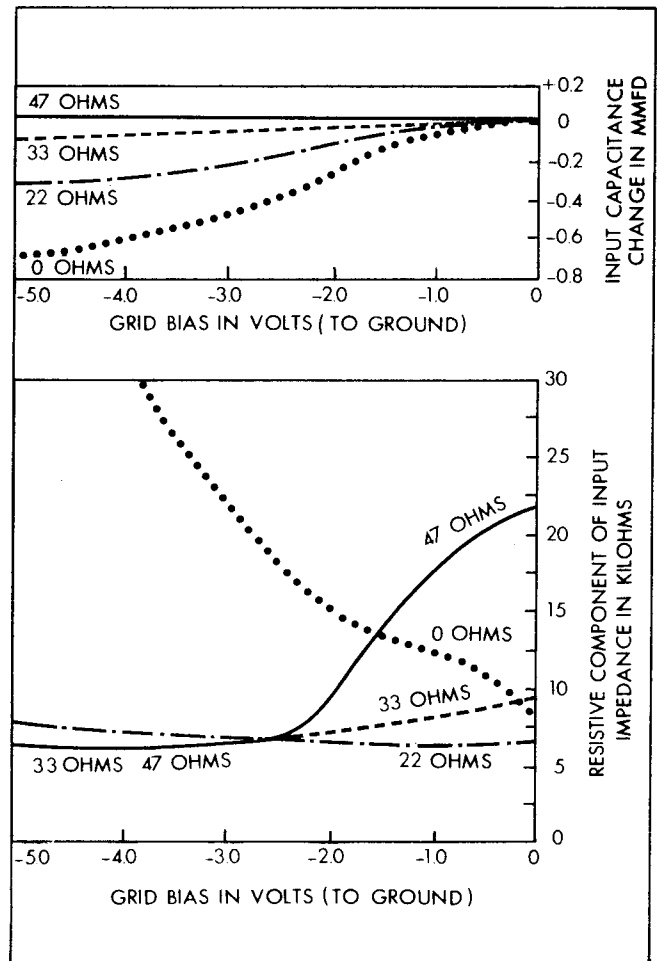

Figure 8-34. Reactive and resistive components of input impedance at 100 Mc

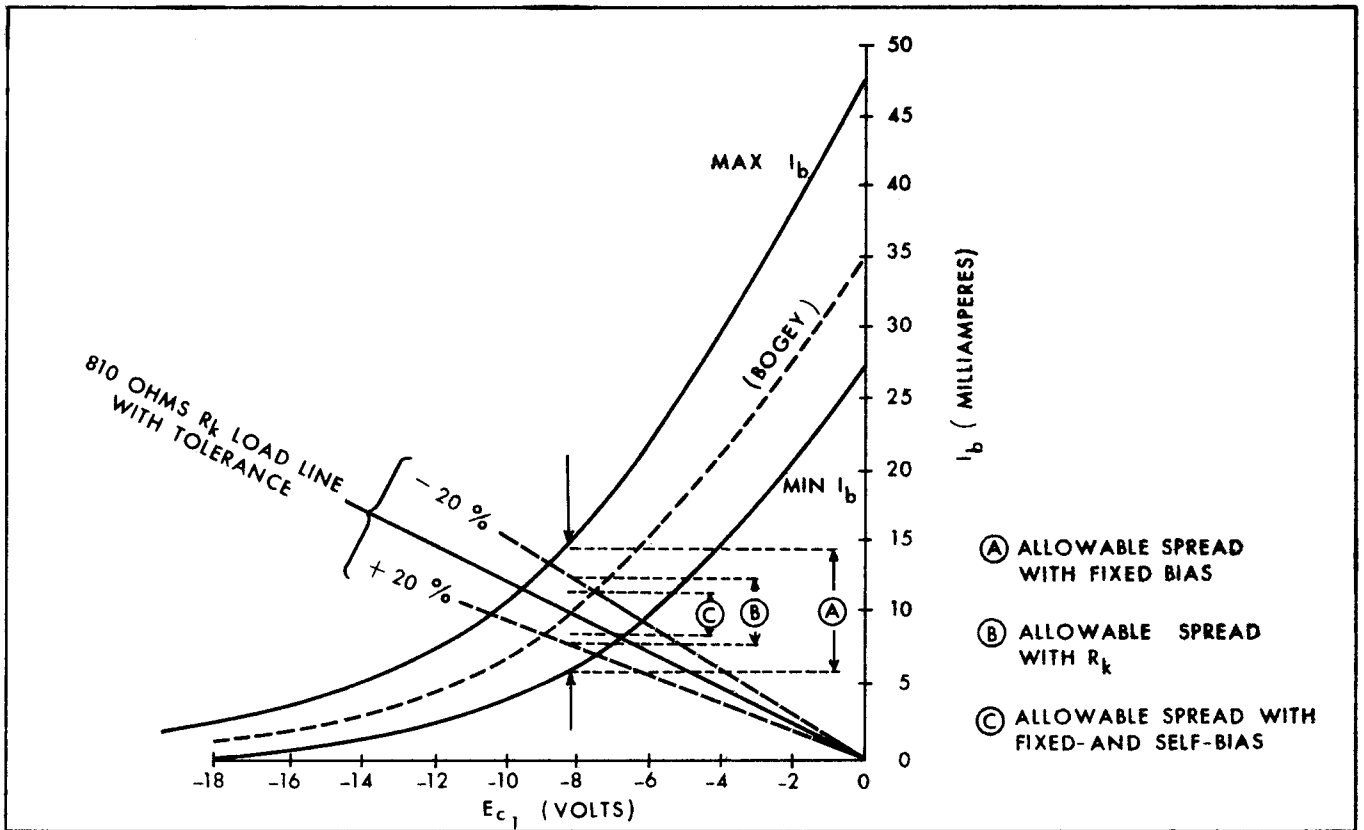

Figure 8-35. Effect of  $R_k$  on characteristics spreads

-1.8. A better than 2 to 1 improvement in circuit uniformity can thus be achieved. Even further improvements may be obtained with combinations of fixed- (+) and self-bias. The dashed lines of resistance represent the limits of  $\pm 20$  percent tolerance on the cathode bias resistor. Lack of control here can introduce at least as much variation as can the tubes. However, in resistors we are fortunate that tolerances better than 20 percent are available.

The same sort of stabilizing effect against tube-to-tube variation may be employed in the screen circuit of pentodes. Use of a screendropping resistor instead of a stiff screen supply will give the effect shown in Figure 8-36. With nominal screen dropping resistor, the spread of screen current is thus reduced from 4 milliamperes to about 2.3. The accompanying change in screen voltage has a further stabilizing effect on the plate current and  $S_m$ , as well as having other interesting characteristics. The combined effect of cathode bias and screen stabilization can compress the spread of tube characteristics by a very considerable amount. The dotted lines indicate the spread caused by resistance tolerance.

It is beyond the scope of a handbook to go deeply into the principles of feedback. The few simple d-c cases thus far considered will suggest many variations.

Dynamic Feedback. In the d-c feedback cases, it was always assumed that the various resistances

introduced were so bypassed that they did not exist for frequencies within the passband of the unit. When this restriction is removed, feedback can be an exceptionally powerful tool in designing for changes in tube characteristics, tube-to-tube variation, and even supply voltage fluctuations. It lies within our power to build a feedback amplifier with output constant to  $\pm 0.1$  percent, using tubes that vary by  $\pm 30$  percent. This would seem like a very desirable situation, except that it costs something in circuit complexity. The need to provide excess gain before feedback requires additional tubes and increases the probability of catastrophic failures by some measurable amount. Thus, feedback is not a cure-all, but when used carefully, with the attendant drawbacks in mind, it becomes a very useful device.

A Design Approach. As a circuit design approach, it is quite often helpful to set up a standard checklist against which the design may be compared to assure adherence to conservative design principles. Thus:

#### Sample checklist

1. Does the operation of the circuit subject the tube to any condition that approaches the absolute rating for the type? Do the usually allowable or normally encountered variations of supply voltage, component tolerance, or circuit adjustment cause the tube operating point to approach any maximum or minimum rating?

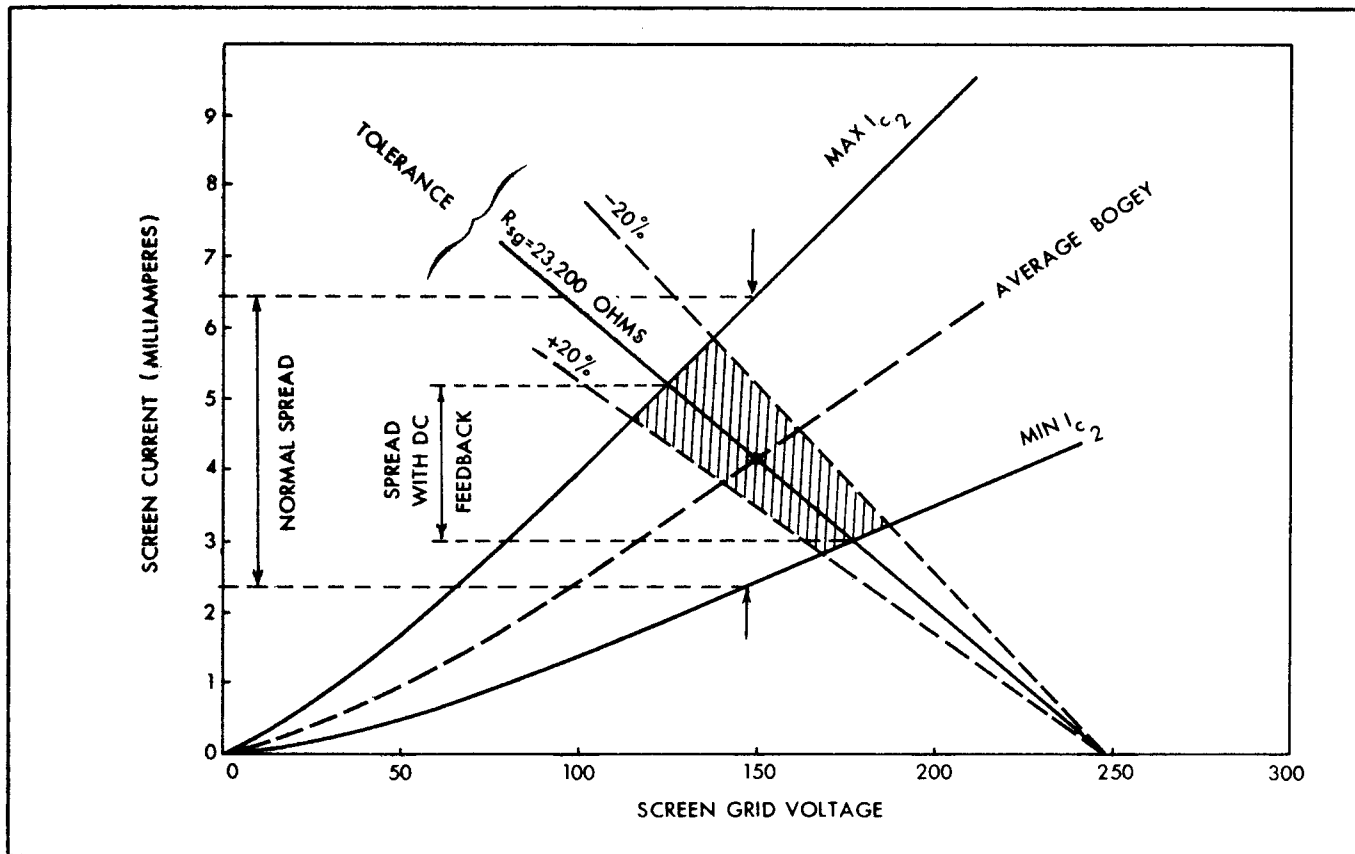

Figure 8-36. Stabilization effected by use of screen dropping resistor

**Ratings checklist**

- Plate voltage (dc) max \_\_\_ min \_\_\_
- (ac peak) max \_\_\_
- (peak inverse) max \_\_\_
- Screen voltage max \_\_\_
- Control grid voltage max \_\_\_ min \_\_\_
- Heater-cathode voltage max \_\_\_
- Grid circuit resistance max \_\_\_
- Total cathode current (dc) max \_\_\_ min \_\_\_
- (peak) max \_\_\_
- Plate dissipation max \_\_\_
- Screen dissipation max \_\_\_
- Allowable grid current (dc) max \_\_\_
- Bulb temperature max \_\_\_
- Mechanical ratings: shock max \_\_\_
- vibration max \_\_\_

**Heater current**

- (series strings) max \_\_\_ min \_\_\_
- Interelectrode capacitance (r-f circuits) max \_\_\_ min \_\_\_
- Amplification factor max \_\_\_ min \_\_\_
- Plate resistance max \_\_\_ min \_\_\_
- Special performance tests (end-of-life point) max \_\_\_ min \_\_\_

2. Does the applicable MIL-E-1B or JAN specification control the characteristics of importance to this circuit? Will the circuit operate satisfactorily with tubes having the full range of characteristics allowable in the specification?

**Characteristics checklist**

- Plate current (before and after life) max \_\_\_ min \_\_\_
- Screen grid current max \_\_\_ min \_\_\_
- S<sub>m</sub> (before and after life) max \_\_\_ min \_\_\_
- (reduced heater voltage) max \_\_\_ min \_\_\_

Often, it is not at all obvious whether the tube under consideration is satisfactory in all these respects. Considerable engineering dogwork lies ahead before we can check off the items applicable. In simple circuits where the behavior is straightforward and fully understood, it is possible to make a series of calculations using the limiting values of tube characteristics to determine the range of circuit operation resulting from each characteristic spread. In some cases, it is even possible to combine several end-of-life or low-limit characteristics at once and gain a fair idea of actual circuit operation in the limit by calculation only.

It is more often true, however, that the exact manner in which a characteristic enters into the final performance is not amenable to calculation. Approximations can be used, but in many instances, it seems more realistic to determine a characteristic vs. performance relation by empirical methods from the circuit itself. This would be quite simple if every

engineer had a stock of high- and low-limit tubes that just made the limit of each characteristic specified. Of course, he would need such a set for each type employed. The design engineer obviously has no such aid available, and he obviously cannot assume that the tubes supplied by any one manufacturer will contain such limit tubes. In general, the situation shown in Figure 8-37 exists.

Semistatistical Methods. Thus, from simple tests of the tubes on hand, it is not possible to make an immediate statement about the expected total range of circuit performance. However, if the tubes on hand are not identical, and some difference in circuit performance is measurable, we may be able to plot a scatter diagram of some characteristics of interest vs. overall circuit gain, output, or whatever is our final measure of circuit performance. Such a scatter diagram is shown in Figure 8-38 for a hypothetical circuit.

The next step is to place a line through the scattered points that most nearly approximate the average. This line will divide the points very nearly equally above and below it. A second line is now drawn parallel to our "line of estimation" (or average line) in such a way that 1/6 of the total number of points are above it. A third line is drawn to the line of estimation so that 1/6 of the total points are below it. Then, approximately 2/3 of the points lie between these lines. The vertical distance between these bounding lines is twice the "standard error of estimate"  $2 S_y$ . This distance  $2 S_y$  is now measured off vertically

from the line of estimation and lines are drawn parallel at this spacing above and below the line of estimation. These lines are called the "confidence limits."

These confidence limits tell us that 95 percent of the tubes encountered will fall within these boundaries.

This method of establishing a correlation is approximate and dodges much of the arithmetic of statistical methods, and yet is quite as accurate when the coefficient of correlation is high. The coefficient of correlation may be calculated by an additional construction on Figure 8-38. Two lines are drawn parallel to the X-axis, so that 1/6 of the total points are above and below them. The spacing between these lines is  $2 \sigma_y$ . The coefficient of correlation  $r$  is now

$$r = \sqrt{1 - \frac{S_y}{\sigma_y}}$$

This correlation coefficient is a measure of the probability that the association made is not a chance occurrence and therefore meaningless.

It is now possible to test the significance of the data and to determine the probability of a chance occurrence. Let

$$F = \frac{(N - 2) r^2}{1 - r^2}$$

This value of  $F$  is compared with a critical figure for  $F$  determined from tables and the sample size. /17/ Data taken from this table are shown in a rearranged form.

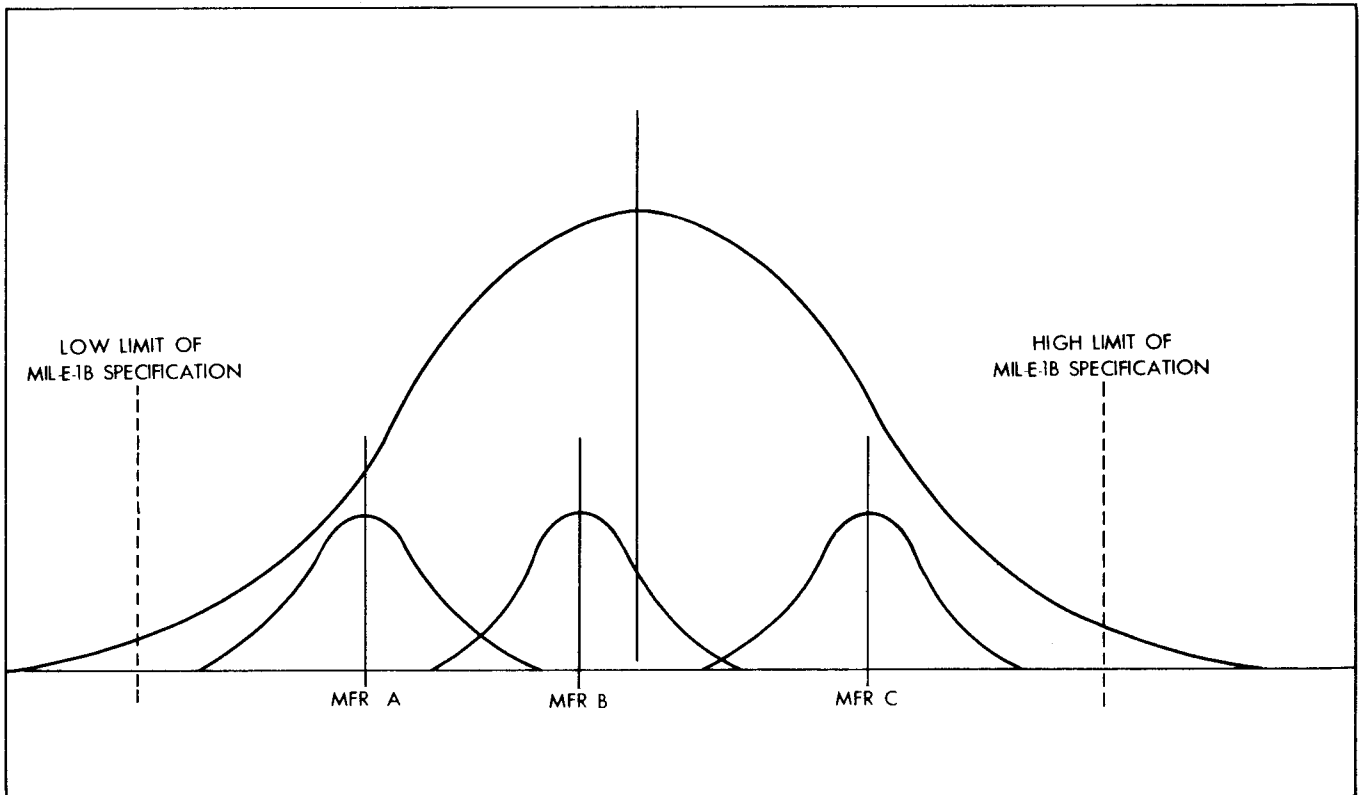

Figure 8-37. Variation of tube characteristics among different manufacturers

Values of F at selected probability

N-2	Probability of chance occurrence		
	0.05	0.01	0.001
1	161.45	4,052.20	405,284.00
5	6.61	16.30	47.04
10	4.96	10.00	21.04
25	4.24	7.77	13.88
60	4.00	7.08	11.97
120	3.92	6.85	11.38
$\infty$	3.84	6.63	10.83

If the calculated figure for F is greater than that of the table for the given sample size (less 2), then the probability of the established correlation being a chance occurrence is less than that shown at the top of the column. For example, a value of F of 13.88 in a 27-tube sample would indicate a probability of one part in a thousand that the correlation under consideration was a chance occurrence.

By semistatistical methods such as these, or by more accurate approaches, it is possible to establish the spread of circuit performance to be expected from limit tubes, and, finally, we may complete our checklist.

- 3(A). Does the specification of the type selected adequately control tube detriments? Will the circuit operate satisfactorily over the full range of detriments allowed by the specification?

Grid current (gas)  
Cutoff bias  
Heater-cathode leakage  
Interelectrode leakage

- 3(B). Is the circuit operation dependent upon any uncontrolled detriment or basic tube limitation?

Initial velocity currents  
(Contact potential)  
Cathode "interface impedance"  
Grid emission  
Secondary emission

In an examination of the circuit response to tube detriments, it is possible to use actual limit or out-of-specification tubes, but in many instances the best approach is simulation of the effect with external resistances.

When the prototype equipment has come along far enough, it should be subjected to an operational life test under simulated actual life conditions. A life test often reveals unsuspected trouble points./6/

## TRANSISTORS

Transistors are not covered in this chapter. As late as November 1954, when the agenda were issued for the RETMA Electronics Application Committee (Reliability) meeting in Washington, November

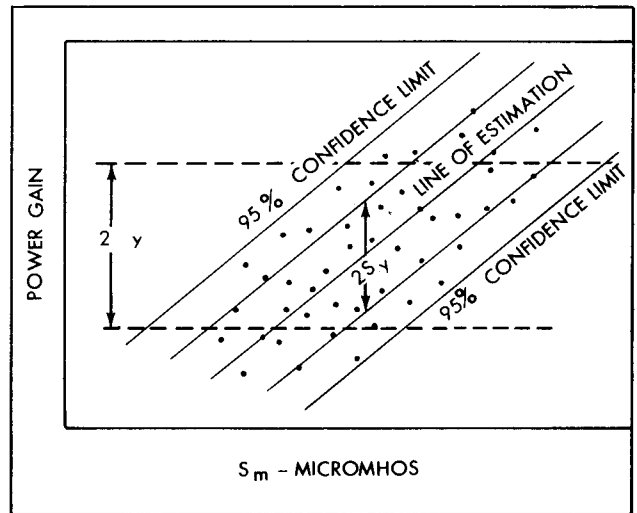

Figure 8-38. Scatter diagram of circuit performance for a hypothetical circuit

30, 1954, it was stated "At the present state of the art, in spite of tremendous progress, the uniformity and performance of transistors is such that a satisfactory margin of safety cannot be guaranteed for most military applications from a reliability standpoint."/18/

When the reliability of transistors has reached the point where it is safe to apply them to military electronic apparatus, it is certain that many advantages will accrue. They will enable designers to save space, weight, and power requirements, and may enable engineers to build long life into equipment. A computer described at the 1952 RCA Laboratories Symposium in Princeton consumed 2 watts, compared to a tube computer of comparable performance that required 60 watts. A reduction by a factor of 10 in physical volume has been achieved by using transistors instead of tubes in a typical amplifier.

Transistors will require new design approaches because, while they seem to do the same things tubes do, they perform these functions in a new way. As a single example, they are low-impedance devices, whereas tubes are high-impedance components. This will make it possible to achieve high gain in small space, without the troubles of stray capacitance. They are fast-operating (have short-time constants), but at present they are unstable with time and temperature, and uniformity in characteristic has not been achieved. /19/

## FIXED RESISTORS

Carbon resistors by the multimillions have been used in home radios and TV receivers for years without excessive failure. One must assume, therefore, that the circuits in which they appear are not critical as to the exact value of resistance at any one moment, or that the resistors in this service do not change radically in value, or that the environment is vastly better than that existing in military equipment,

because it is a fact that carbon fixed resistors have attached to themselves the greatest onus for failure in service. One widely quoted statement is, "Composition resistors are inherently unstable. In normal use they can be expected to age — 15 to 25 percent in addition to initial manufacturing tolerances. They should be used only where circuit requirements are not critical, and even then it is preferable to use a  $\pm 5$  percent resistor." /2/

In the Bell report, however, it was stated that the principal cause of composition resistor failures was overloading caused by failure of other components, primarily vacuum tubes. If this is generally true, it is a bit rough on the composition resistor to blame it for so much failure; it was never designed to be used in place of a fuse.

Failure vs. Change of Value. One of the great virtues of the composition resistor, aside from its low cost, small size, and extreme availability, is the fact that in its manufacture the wire lead is embedded in the resistance material and molded there under great pressure. The lead touches the resistive material in an infinite number of points. The entire unit is then coated with an insulating shell.

Absolute failure — open circuit — is not likely to occur unless the unit is manhandled to the point of breakage — not the resistor's fault — or the unit is burned up by overloading. Although the absolute value of resistance may change because of many causes, an open circuit is extremely unlikely, so that the user of the equipment has some sort of service, even though it is not the best.

If the units can pass MIL-R-11A specifications, if they are used with due consideration for their temperature and voltage coefficients and the derating factors recommended by the manufacturer, and if the environment is not more rigorous than the MIL specifications cite, it seems certain that the resistor will fulfill its function properly.

Stability. In a shelf life test on 280 type CM-1/3E RC 20 resistors run by Stackpole Carbon Company, the values from 10 ohms to 22 megohms showed a slow positive resistance change. At the end of 24 months, the average resistance change was 3 percent. The figures shown in Figure 8-39 give the distribution of resistance changes at various points along this shelf life test. It should be noted that these figures are based on a sampling of resistors from a wide range. Significant differences might be noted if specific, discrete ranges of resistors are tested.

Stability vs. Tolerance. The confusion between these terms has been noted elsewhere in this handbook. A  $\pm 5$  percent resistor is one whose resistance value is within  $\pm 5$  percent of its rated value when tested at room temperature and at some specified voltage below the rated value. Under other conditions, its actual value may be somewhat different. Therefore, initial tolerance is a test condition. It is not associated with ambient temperatures, wattage dissipation, and/or voltage. Stability refers to the performance of components in use, and is a function of the environ-

mental conditions indicated above. The designer must know what he wants and must be able to tell the vendor what he wants.

Temperature Coefficient. Composition resistors employ a resistance material (carbon, graphite, and the like) in a dielectric binder, and the proportion of one to the other varies with resistor value, manufacturer, and so on. The several elements have varying temperature coefficients. Much improvement has been made within recent years in temperature characteristics, but they still have to be taken into account where high stability or accuracy is necessary.

Boron-treated carbon deposited on a ceramic form has temperature coefficients of the order of 0.006 percent per degree C for units below 100,000 ohms and 0.028 percent per degree C for units above 100,000 ohms through the range -55 C and +105 C.

Precision deposited-carbon units have temperature coefficients shown in Figure 8-40. The values shown are for values of temperature from -55 C to +105 C.

High-voltage film or spiral type resistors have a coefficient of about -0.05 percent per degree C from +25 to 100 C. Although this coefficient is typical for this type of resistor, it should be pointed out that variations will occur in batches having various range limits.

Nobeloy film resistors have a rating of less than +0.05 percent per degree C for units of 1 megohm or lower and -0.08 percent per degree for higher-resistance units.

Controlled Temperature Characteristics. Research indicates that thin metal films laid down by vacuum evaporation lend themselves to control, so far as their temperature characteristics are concerned. Thus, it is possible to produce units of virtually any desired coefficient within certain ranges. At 100,000 ohms the coefficient can be specified to any value between -200 to +200 parts per million (ppm) per degree C; units with low coefficient, less than 5 ppm per degree C, retain this characteristic over a moderate temperature range; an 11,000-ohm resistor with a temperature coefficient close to zero for the range from 0 C to 100 C can be made. The desired value can be obtained within  $\pm 20$  ppm per degree C. The noise is of the order of 0.3 microvolts per volts. Figure 8-41 shows the range reported by Rockett. /20/

Noise Characteristics. Since the composition resistors are made from nonhomogeneous material, that is, the unit is a composition of resistive material in contact with nonresistive material, they are noisier than units made from a pure metal. The noise is a function of voltage and is of the order of a few microvolts per volts. It is higher for the units of higher resistance. Marsten /21/ shows that the noise is of the order of 1 to about 3 microvolts per volts for the widely used 1/2- and 1-watt units in resistances from 1,000 ohms to 10 megohms.

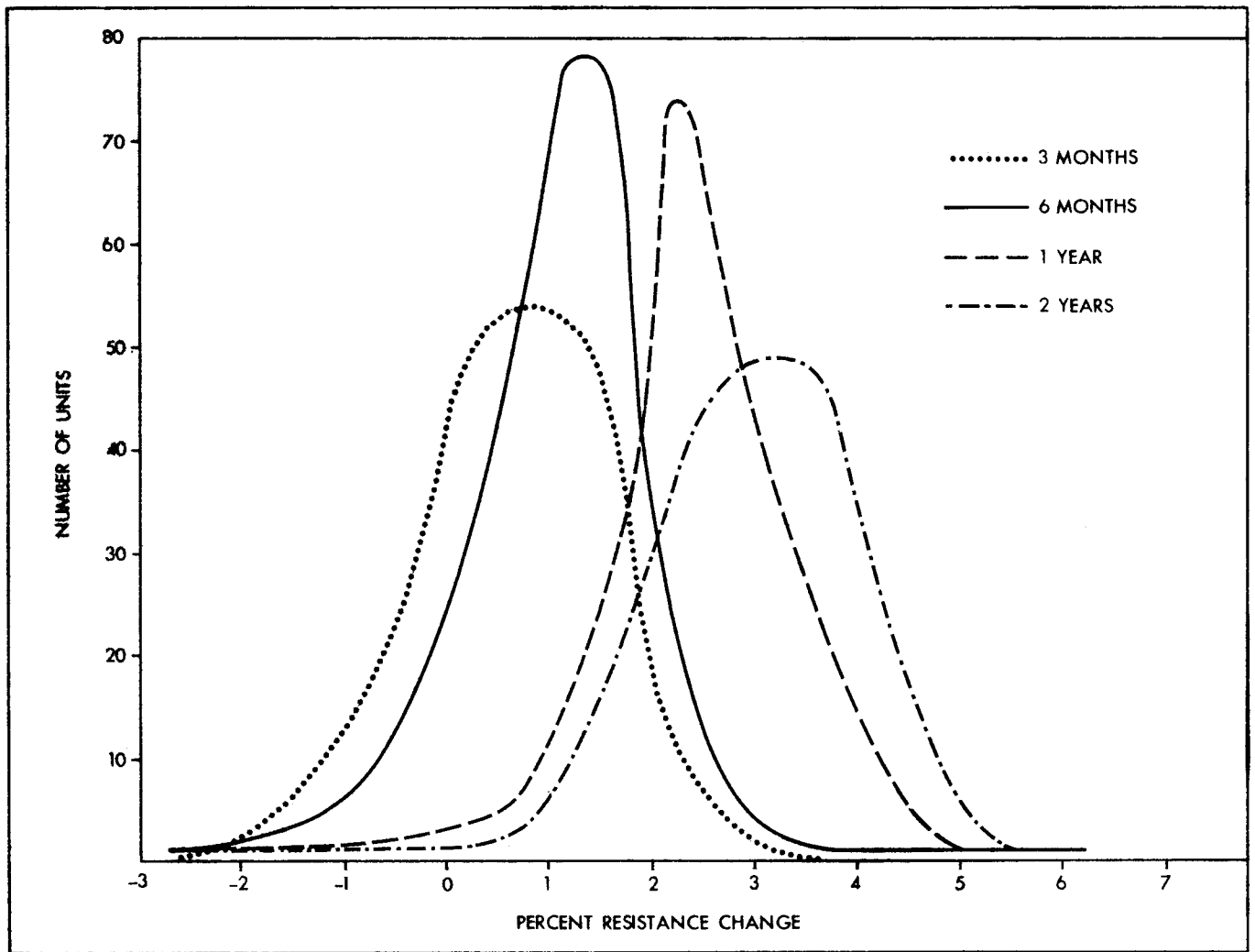

Figure 8-39. Shelf life characteristics for fixed composition resistors

**Derating.** Since the resistance under load is a function of temperature, resistors must be derated according to the ambient temperature so that the resultant unit hot spot temperature — that is, its total hot spot temperature as a result of the ambient plus the rise in temperature because of the power it must dissipate — is not outside the tolerance limits. The derating factors are not imposed because of danger of the unit burning up; they are to protect the circuit from malfunction because of resistance variation. (See Figure 8-42.)

**Glass-Type Resistors.** By employing glass as the base material on which the resistive material is placed, resistors capable of operation at high temperatures have been secured. There are three general types: a high-frequency type, in which the film thickness is less than the depth of penetration at v-h-f; an accurate grade; and a high-temperature resistor. Table 8-5 gives the ratings in which stability is the permanent resistance change after 500 hours of operation at maximum rating and 40 C ambient. Temperature coefficient is the maximum absolute value and is for the higher resistance units. For resistances

of from 10 to 100 ohms, the coefficient is positive and increases toward 0.03 percent per degree C as a maximum.

These glass type units are made in ratings of from 1 to 150 watts for the high-frequency type, 0.5 to 2 watts for the accurate grade, and 1 to 115 watts for the high-temperature units based on a 220 C hot spot at 40 C ambient.

Table 8-5. Film-on glass resistors (percent per degree C)

Characteristic	High frequency	Accurate grade	High power
Tolerance	± 2, 10, and 15	± 1	± 1.2
Stability	3	0.5	2
Temp coeff	0.03	0.02	0.02

**Resistor Drift.** There is no doubt that resistors of the type being described have better life characteristics than those of an earlier generation, in terms of research years. Life tests being conducted

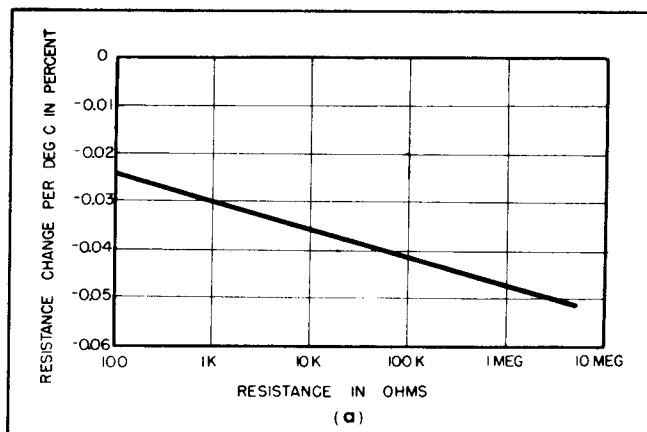

Figure 8-40. Typical temperature coefficient characteristics for deposited-carbon resistors

at the International Business Machines Corporation laboratory /22/ indicate that composition-carbon and deposited-carbon resistors change with life on load less than 10 percent, and most of those being tested drifted only a few percent over a period of 5,000 hours and more. Although there is considerable difference between units made by different manufacturers, all

units seem to be much better than the figures quoted by Bell Laboratories, /2/ which indicated that in normal use composition resistors may be expected to age -15 to +25 percent in addition to normal manufacturing tolerances. One batch of varnish-coated deposited-carbon resistors under test at the IBM laboratory exhibited a total spread of only 0.3 percent after 6,000 hours of use.

#### WIRE-WOUND RESISTORS

Where the more stable characteristics of wire-wound fixed resistors justify the expense over composition-and deposited-carbon units, they are widely used. Over the past 5 years, considerable improvement has been made so far as accuracy, stability, better temperature coefficients, higher temperature ratings, smaller size, and better wire protection are concerned. /20/

Electrical failures at the terminal to winding connection were the chief fault discovered in the Bell Laboratories-Navy reliability program. /2/ More modern techniques seem to have overcome some of this trouble.

The data in Table 8-6 summarize the facts on power wire-wound resistors as of October 1954. /23/

Table 8-6. Power wire-wound resistors

Characteristic	Radial lug terminal styles See Figure 8-43 Styles RW29 to RW39 of MIL-R-26B	Axial lug terminal styles See Figure 8-44 Styles RW50 to RW54 of MIL-R-26B	Axial wire lead terminal styles See Figure 8-45 Styles RW55 and RW56 of MIL-R-26B and newer types
1. Wattage ratings (based on 25 C ambient temp)	8 to 166 watts in 12 standard sizes	5 to 120 watts in 5 standard sizes	5 and 10 watts
2. Size (inches)	5/16 dia x 1 3/4 to 1 5/16 dia x 12	7/16 dia x 1 3/8 to 1 1/8 dia x 9	1/4 dia x 1 to 3/8 dia x 1 3/4
3. Maximum hot spot temperature (based on 25 C ambient)	275 C for Characteristics F and G; 200 C for Characteristic J	275 C for Characteristics F and G; 200 C for Characteristic J	275 C for Characteristics F and G; 200 C for Characteristic J
4. Power derating for high ambient temperature (max hot spot temp must not be exceeded)	See Figure 8-46	See Figure 8-46	See Figure 8-46
5. Outer protective coating	Vitreous enamel or high-temperature cements	Ceramic tube, vitreous enamel, or cement	Ceramic tube, vitreous enamel, or cement
6. Mounting (depends on vibration requirements)	Through-bolt or mounting brackets (see Figures 8-47 and 8-48)	Mounting clamps (see Figure 8-49)	Mounted by wire leads only where vibration is not a problem; otherwise, use mounting clamp (see Figure 8-50)



Table 8-6. Power wire-wound resistors (cont)

Characteristic	Radial lug terminal styles See Figure 8-43 Styles RW29 to RW39 of MIL-R-26B	Axial lug terminal styles See Figure 8-44 Styles RW50 to RW 54 of MIL-R-26B	Axial wire lead terminal styles See Figure 8-45 Styles RW55 and RW56 of MIL-R-26B and newer types
7. Maximum voltage across resistors	Limited by wattage rating and resistance value, up to maximum recommended voltage of 700 volts per linear inch of resistor.		
8. Secondary insulation requirements	Where high voltages exist between resistor and ground, secondary insulation should be used. Insulating washers are supplied by manufacturers. See Figures 8-46 and 8-47.	Ceramic shell types are insulated for at least the resistor voltage rating. Manufacturers supply higher voltage ratings. Vitreous enamel and cement coatings should not be mounted in contact with chassis or other metal parts.	Ceramic shell types are insulated for at least the resistor voltage rating. Manufacturers supply higher voltage ratings. Vitreous enamel and cement coatings should not be mounted in contact with chassis or other metal parts.
9. Humidity performance	Specification MIL-R-26B calls for two characteristics, Characteristic F for immersion-resistant units and Characteristic G for moisture resistant. Units passing Characteristic G humidity tests are generally suitable for all applications.		
10. Resistance range	1.0 ohm minimum up to 100,000 ohms maximum value, using 0.0025-inch diameter wire. Actual maximum value depends on wattage rating and size. Higher values are available for smaller wire diameter (see 11 below).	1.0 ohm minimum to 50,000 ohms maximum value, using 0.0025-inch diameter wire and single layer winding. Ceramic jacketed types, using insulated wire and multilayer winding, provide 100,000 ohms maximum. Higher values are available for smaller diameter wire (see 11 below).	1.0 ohm minimum to 2,200 ohms maximum for 0.0025-inch diameter wire and single layer winding. Ceramic jacketed types, using insulated wire and multilayer winding, provide 6,300 ohms maximum. Higher values are available for smaller diameter wire (see 11 below).
11. Wire size limitations	0.0025-inch minimum diameter wire generally called for in military specifications provides large factors of safety under high humidity electrolysis conditions. Wire diameter down to 0.00175-inch diameter is permitted in military specifications, and high quality commercial designs consider 0.0015-inch diameter wire adequate for resistors fully meeting humidity electrolysis requirements of MIL-R-26B. <u>Smaller wire diameter provides substantially higher resistance values</u> , up to three times those shown in (10) above. Wire diameter smaller than 0.0015-inch should not be used, except in hermetically sealed designs or in constructions fully investigated for electrolysis performance.		
12. Resistance tolerance	Standard resistance tolerance for power wire-wound resistors is $\pm 5\%$ . Tolerances down to $\pm 1\%$ are available. Where tolerances closer than $\pm 3\%$ are specified, special attention should be given to stability requirements. (See 13 and 14 below.)		
13. Temperature coefficient of resistance	Temperature coefficient is largely dependent on composition of alloy used in resistance wire. Various alloys are used, depending on resistance range and size. Military Specification MIL-R-26B permits temperature coefficients of $\pm 0.04\%$ per C for low valued resistors, and $\pm 0.026\%$ per C for higher resistance value units. Wire alloys having coefficients as low as $0.002\%$ per C are available. Temperature coefficient produces shift in resistance of unit with change in ambient temperature, or with self-heating due to power dissipation, and should be provided for in circuit design requirements.		
14. Resistance stability	Resistance stability is the permanent change from initial resistance value with time and is due to aging, thermal cycling, or stress resulting from vibration and shock. Actual stability depends on many features, such as construction, wire alloy, and range of thermal cycling and duration. Close initial resistance tolerance does not insure high stability. Manufacturers can provide constructions and stabilizing treatments to provide stability of $\pm 1\%$ , on special order. <u>Standard resistors will have drifts in value as large as <math>\pm 5\%</math> over long periods of time.</u>		

Table 8-6. Power wire-wound resistors (cont)

Characteristic	Radial lug terminal styles See Figure 8-43 Styles RW29 to RW39 of MIL-R-26B	Axial lug terminal styles See Figure 8-43 Styles RW50 to RW54 of MIL-R-26B	Axial wire lead terminal styles See Figure 8-44 Styles RW55 and RW56 of MIL-R-26B and newer types
15. Noninductive resistors	Noninductive resistors can be produced in these constructions, but are not included in MIL-R-26B requirements. Ayrton-Perry type winding can be used to reduce residual inductance at low frequencies. <u>Standard resistors are inductively wound</u> , and actual residual parameters depend on resistance value, resistor size, and frequency. Residual parameters of either "inductive" or "noninductive" windings depend on measuring frequency and may be either inductive or capacitive in nature. Where noninductive performance is necessary, specify exact requirements to resistor manufacturer.		

Application Notes

1. When resistors are mounted in rows or banks, they must be so spaced that, taking into consideration the restricted ventilation and heat dissipation by the nearby resistors, none of the resistors in the bank or row exceeds its maximum permissible hot spot temperature. To assure this, an appropriate combination of resistor spacing and resistor power rating must be chosen.
2. The styles of resistors to be used in equipment should be so chosen that, when mounted in the equipment, they will not operate at a temperature in excess of their rating. This should be true under the worst possible specified conditions, that is, with the equipment operating as follows:
  - (a) In the maximum specified ambient temperature.
  - (b) Under conditions producing maximum temperature rise in each resistor.
  - (c) For a sufficient length of time to produce maximum temperature rise, or for maximum specified time.
  - (d) With all enclosures in place.
  - (e) With natural ventilation only.
  - (f) At high altitude.

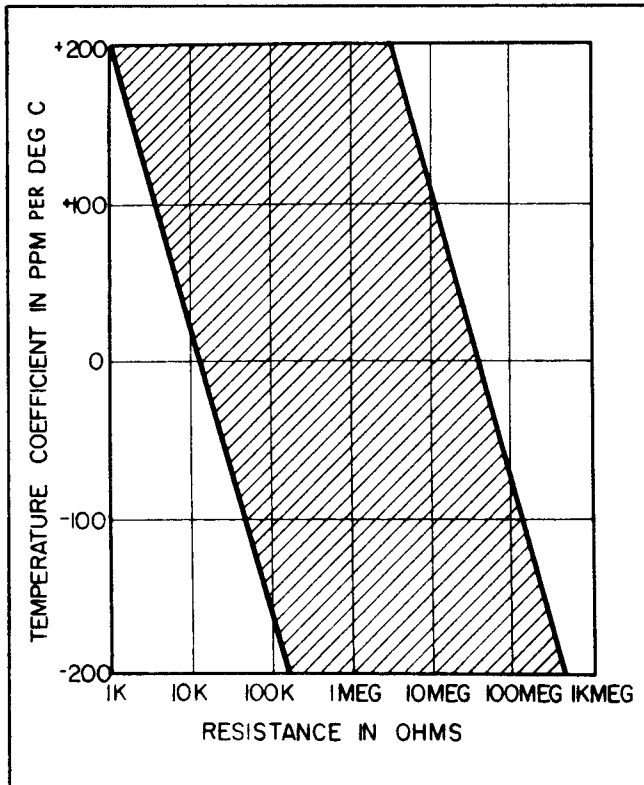

Figure 8-41. Resistors having controlled temperature coefficients can be made in the range shown by the shaded area using mixed-metal films

Specifications. The manufacturer will want to know from the circuit and equipment designer the following data when he is asked to furnish resistors for new equipment.

Resistance in ohms or megohms

Resistance tolerance in percent  
 Allowable aging tolerance over life in percent  
 Matched pair tolerance in percent

Power dissipation in watts  
 Rated watts dissipation  
 Average (actual) dissipation  
 Peak (actual) dissipation

Voltage across resistor, dc  
 ac, rms  
 pulse width  
 repetition rate  
 rate of rise and decay

Temperature coefficient in ppm per °C or max change in resistance

Operating temperature range °C

Windings Inductive or noninductive  
 Frequency of current in cps  
 Maximum residual inductance or capacitance

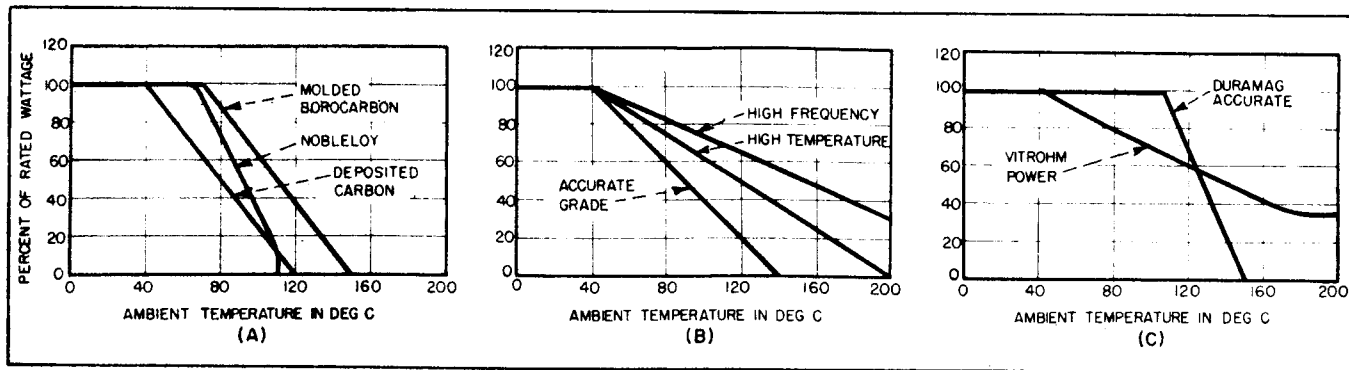

Figure 8-42. Derating curves for carbon-film resistors (A), film-on-glass (B), and wire-wound type (C)

Required life in hours

Duty cycle

Dimensions

Terminals

Mounting

Vibration and shock in max g, frequency, inches of excursion

Moisture resistance

**Resistor Misapplications.** It seems difficult to misapply so simple a device as a resistor, aside from overloading it, but the following case histories show that it can be done!

Miniature 1/4-watt composition resistors with a thin insulating molding were found to be mechanically unreliable. These resistors were assembled in the equipment in such a manner, that to dip-solder the leads, it was necessary to immerse the entire resistor, body and leads, in a molten solder bath at 270 C. Resistors of this class are not designed or intended to meet this kind of service.

High-stability deposited-carbon resistors were used in an amplifier. The prototype equipments

produced by the development company were satisfactory, but the ultimate manufacturer found that his amplifiers did not meet the specifications. The trouble was traced to the resistors, which were considerably outside the original 1 percent tolerance. Investigation disclosed that the manufacturer had sprayed the resistors with a fungicidal compound that attacked the insulating coating and the resistance film of the resistors, resulting in large resistance changes. The prototype was not treated in this way.

Deposited-carbon resistors were used in a computer and were claimed to be unreliable in that about 70 percent of them departed anywhere from 1 to 10 percent from the original 1 percent tolerance. Since there were 150 of them in the equipment, both the component manufacturer and the assembler of the equipment were disturbed. It turned out that all but one of the resistors tested well within the desired tolerance when checked on a Wheatstone bridge. The trouble here was inaccurate measuring equipment.

A 2-watt composition resistor, used far below its rating, was giving trouble in that its value changed excessively and the insulation showed signs of discoloration pointing to high temperature. A comparison of the prototype — which had no trouble — with the production models disclosed that in the latter, the 2-watt resistor was mounted cheek-to-cheek with a 10-watt wire-wound resistor operating at high temperature. In the prototype, the two resistors were spaced some distance apart, and the change in location was made to effect some simplification in wiring. The direct heat transfer from the wire-wound resistor to

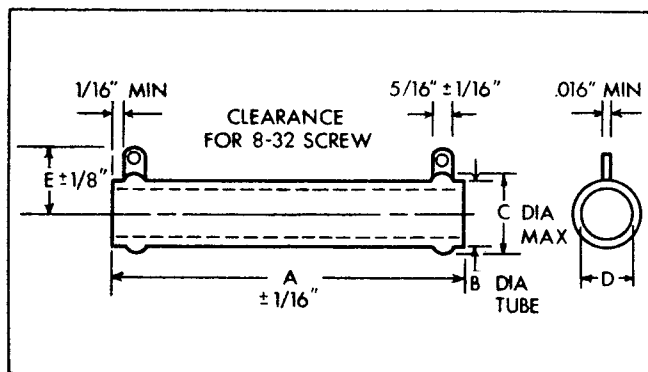

Figure 8-43. Radial lug terminal styles

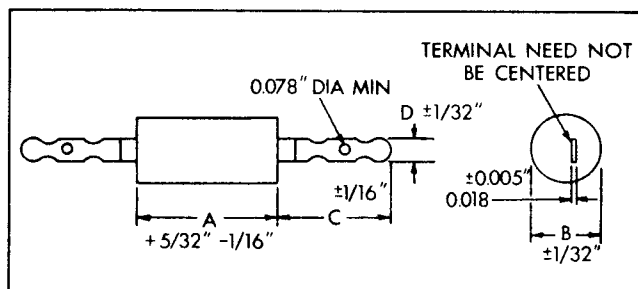

Figure 8-44. Axial lug terminal styles

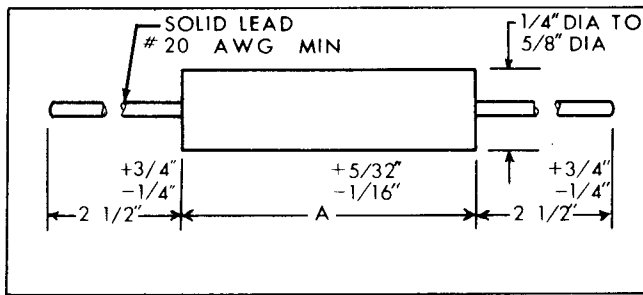

Figure 8-45. Axial wire lead terminal styles

the composition unit, plus the temperature rise in the composition unit, plus the ambient, was sufficient to raise the temperature far beyond that for which the resistor was designed.

In another case, real trouble developed with a special resistor. However, it was mounted so tightly that it was practically impossible to replace it with another type, even though the latter was only 1/32 inch longer.

A 1/2-watt 120-ohm wire-wound resistor molded in bakelite and used in an audio amplifier occasionally exploded like a firecracker. Normal power dissipated in the resistor was considerably below the rating. Investigation disclosed that momentary line faults resulted in line voltages of 110 appearing across the resistor. Ohm's law explains. This 1/2-watt resistor was asked to handle 100 watts under these conditions, and the resistor refused! All components will handle some overload, but probably not a 200-times overload.

Quite often, narrow-tolerance (1 percent) resistors are specified when the designer really wants a resistor that is stable within 1 percent, which means

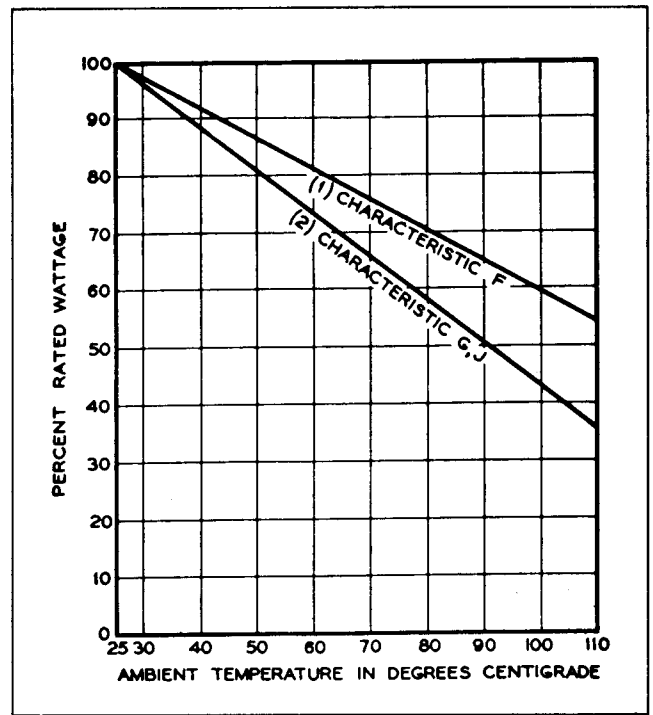

Figure 8-46. Derating curve for high-ambient temperatures

simply that its resistance does not vary with temperature, humidity, frequency, voltage, or power. The absolute value may not be so important — the circuit can be designed for this value — but it should not vary much once it is installed.

A 1-watt deposited-carbon resistor of 1 percent tolerance was changing enough to impair performance.

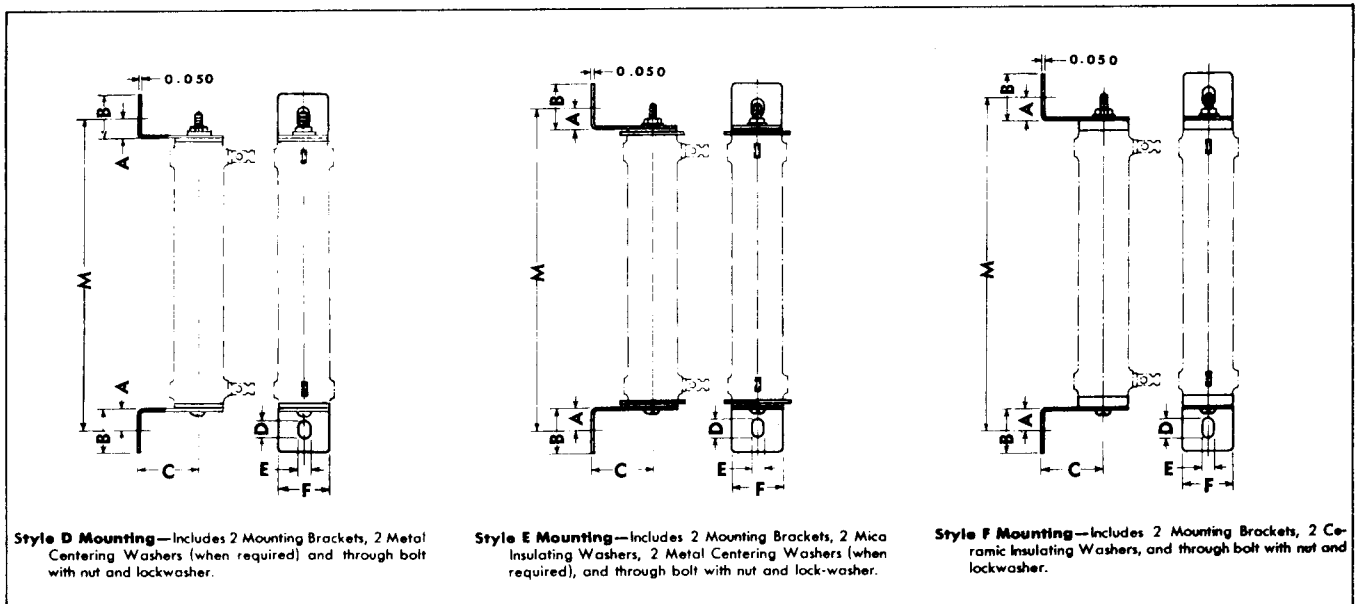

Figure 8-47. Through-bolt horizontal type mounting

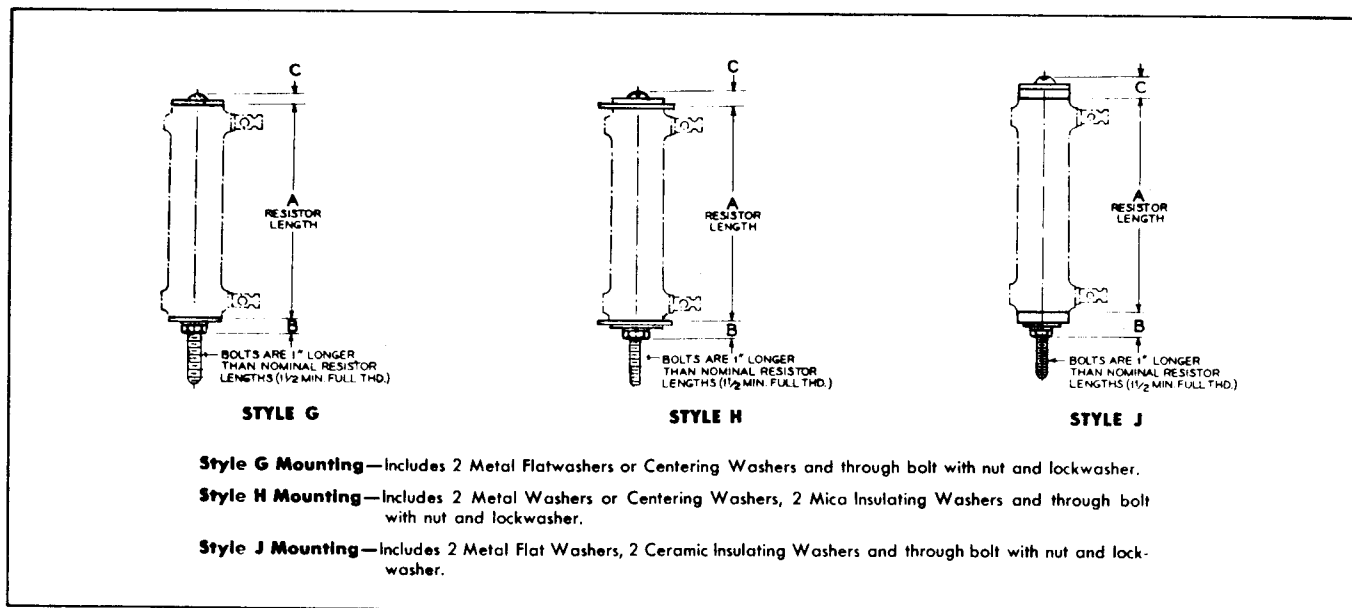

Figure 8-48. Through-bolt vertical mounting

The change was about 3 percent to 4 percent. Operating at full load, this change is normal for a deposited-carbon resistor, which has a temperature coefficient of 200 to 600 parts per million. At full load, the temperature rise was about 25 C. The difficulty here was the confusion in the designer's mind between close tolerance and stability. In this case, a resistor of lower temperature coefficient or a larger deposited-carbon resistor should have been used.

And, of course, there is the other classic example, probably without any foundation in fact, of the test model that almost caused a major air crash. The reason was that in making a last-minute change, a serviceman had used a resistor that had been soldered in and out of many other equipments. As a result, its resistance bore no relation whatever to its color code marking.

In another case, capacitors were continually blowing up. The test equipment supplied with the apparatus consisted of a low-frequency oscilloscope.

Using this instrument, it was proved that the sum of the d-c and peak a-c voltages across the capacitors was not enough to cause the trouble. But a high-speed oscilloscope quickly showed that occasional rapid and high-voltage surges appeared often enough and at the proper instant to overload the capacitors, with resultant failure.

Thus, it can be seen that components cause unreliability — but the responsibility is not solely that of the supplier of the components — the user has some responsibility, too.

Much progress is being made to develop components that will tolerate new and more rigorous environments, but their characteristics must be studied and known by the designing engineer. They should not be taken for granted.

Specifications. The following MIL or JAN specifications control the purchase of the various types of resistors at the present time.

Resistor-Suppressors, Suppression (Radio-Frequency Interference)	71-1585(1)
Resistor-Thermocouple Lead Spool (Supersedes AN-R-13a)	MIL-R-7790
Resistors, External Motor (High-Voltage, Ferrule Terminal Type)	JAN-R-29(4)
Resistors, Fixed, Composition (Insulated)	MIL-R-11A(1)
Resistors, Fixed, (Composition Film, Very-High-Frequency) (With Supplement No. 1 dated 31 December 1952)	MIL-R-10683A
Resistors, Fixed, Composition, Uninsulated	MIL-R-15401A(2)
Resistors, Fixed, Film (High-Stability)	MIL-R-10509A(1)
Resistors, Fixed, Film, High-Stability	MIL-R-4277(USAF)
Resistors, Fixed, Wire-Wound (Accurate) (With Supplement No. 1 dated 21 March 1952) (Supersedes 71-4926)	MIL-R-93A(1)
Resistors, Fixed, Wire-Wound (Low-Power)	JAN-R-184(5)
Resistors, Fixed, Wire-Wound (Power-Type) (With Supplement No. 1 dated 20 March 1953)	MIL-R-26B

Resistors, Fixed, Wire-Wound (Precision High-Temperature)  
 Resistors, Thermocouple Lead Spool (See Bulletin 351)  
 (Superseded by MIL-R-7790)  
 Resistors, Variable, Composition  
 Resistors, Variable Wire-Wound (Low Operating Temperatures)  
 Resistors, Variable (Wire-Wound, Power-Type)

MIL-9-9444  
 AN-R-13a  
 JAN-R-94(2)  
 JAN-R-19(6)  
 MIL-P-22A(1)

### CAPACITORS

The Vitro report /24/ showed that capacitors represented 26.9 percent of the total component parts population of some 20 million and represented 13.7 percent of the total failures for the period studied. The greatest number of failures occurred among fixed paper capacitors (41.8 percent), fixed micas (40.6 percent), and fixed ceramics (6.9 percent). The greatest cause of failure was short circuits, followed by leaky units and by open-circuited units. The highest percentage of failures occurred among capacitors of low population.

Under the Navy-Bell Laboratories study, /2/ 457 capacitors were returned to the laboratories for inspection. Insulation failure (electrical leakage) accounted for 239 of the units tested. Of these, 128 were silver micas in which the trouble was traced to silver migration. Design weakness was indicated as the chief cause of insulation failures in the second largest group, fixed paper units, (88 out of 111 failures).

Reliable Capacitors. Experience of the Bell system and Western Union has indicated that capacitors which are properly made, properly chosen for the job, and properly employed will have long life.

In September 1950, the first submerged d-c telegraph repeater was installed in a deep sea cable of Western Union at a point 170 nautical miles from the coast of Newfoundland. After four months, the repeater was hauled up. Some modifications were made and it was returned to the sea bottom. As of February 1952, it had been in continuous operation since 5 July 1951. /25/

Oil-filled paper-foil capacitors were chosen for the repeater after tests had demonstrated that they would give satisfactory performance when operated under pressure. Pressure increased the capacitance, most of the change occurring in the first 500 psi and reaching a total of about 3 percent at 8,000 psi. Pressure increased the voltage at which breakdown would occur. The units were rated by the manufacturer at 600 volts dc for a life of one year. The individual units were carefully tested prior to inclusion in the repeater. Since capacitor life varies inversely as about the fifth power of the voltage, and since the repeater unit capacitors were to be operated at voltages of 150 or less, long life was expected.

Capacitor Information for Vendor. Aside from the usual characteristics — voltage, insulation resistance, tolerance, and so on — the manufacturer of a capacitor that is to be used in military equipment wishes to know a great deal about the application and conditions of use. This enables him to give proper

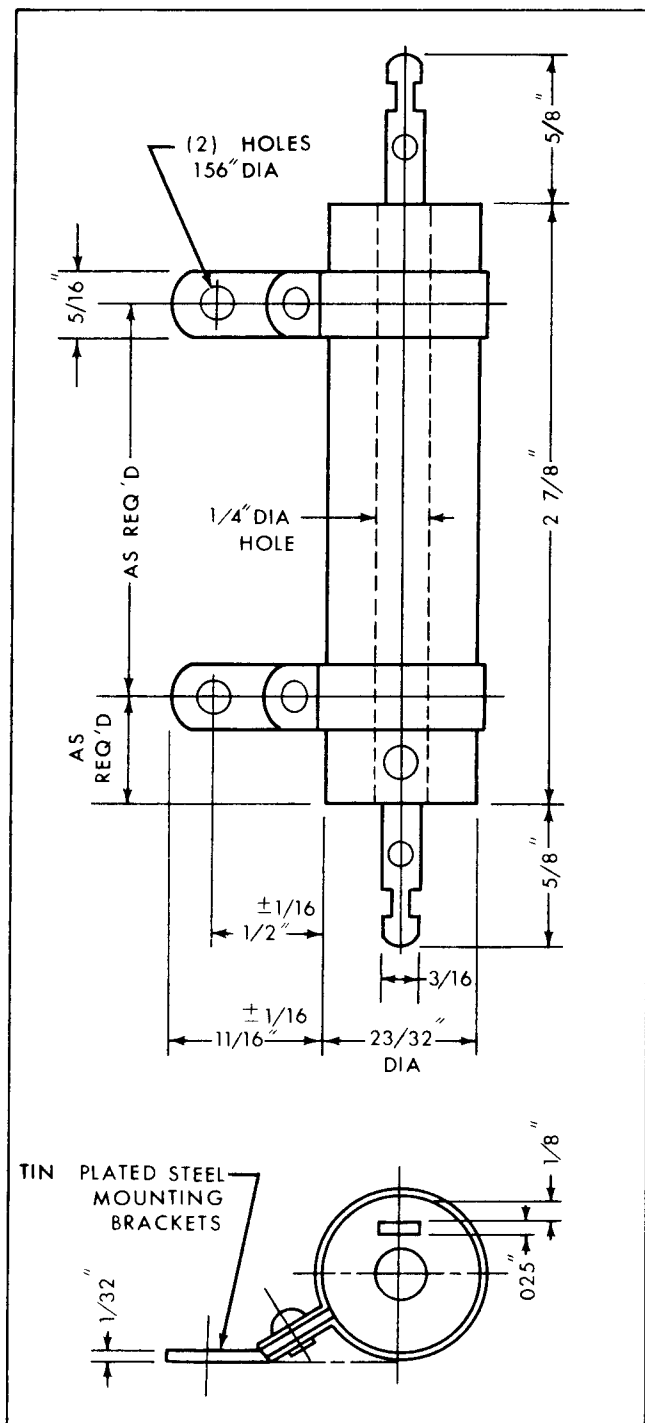

Figure 8-49. Mounting on clamps

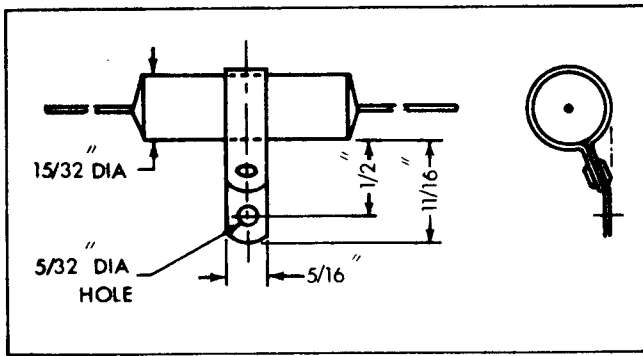

Figure 8-50. Mounting on single clamp or wire leads only

advice about the unit and assures him that the units finally recommended will do the job. Some of the questions to which the vendor wishes answers will force the equipment designer to know a great deal about the equipment. Following are some of the items that affect the design of various capacitor types.

**Electrical.** Type of power supply circuit  
Power supply rating (amperes at volts)  
Ripple voltage (peak to peak) and frequency  
Ripple current and frequency  
Coupling between sections  
Magnitude and duration of pulses  
Magnitude and duration of reversed voltage

**Mechanical.**  
Operating position of terminals  
Altitude requirements  
Method of mounting  
Vibration test  
Shock test  
Salt spray test  
Immersion test  
Humidity test

**Discharge and Pulse Capacitors.**  
Percent discharge  
Percent voltage reversal  
Peak and rms currents  
Total discharges desired  
Discharges per second  
Waveform of voltage  
Load impedance  
Time on rated voltage

**A-C Applications.**  
Percentage harmonics and frequencies  
Peak surge voltage and frequency of occurrence  
Rms current and frequency  
Inductance limit  
Impedance vs. frequency  
Temperature rise limit  
Normal line voltage variation  
Temperature coefficient  
Retrace  
Minimum Q

It is worth noting that insistence on small capacitors may force the vendor to use thin paper, and thus to increase the chances of failure over a larger unit, in which the manufacturer could employ dielectric of greater breakdown voltage. Thus, the manufacturer should be given some freedom in establishing case sizes.

## MICA CAPACITORS

Foil vs. Silver Micas. It has been recommended /26/ that foil types of mica capacitors be employed wherever their characteristics are acceptable and that silver micas be used only where the temperature coefficient and stability dictate their employment. Case sizes smaller than CM-40 in Characteristics C, D, and E are generally silvered micas. Silver micas in Case CM-15 are sometimes chosen because of their small size, although the stability and temperature coefficient in these cases is not the controlling factor in their choice. The following ratings are recommended:

1. Do not exceed the 300-volt d-c rating of silver micas.
2. Unless otherwise specified, maximum peak a-c or pulse voltages should be 250 for both silver and foil micas.
3. Unless otherwise specified, for any combination of a-c and d-c voltage, the peak value should not exceed 250 volts for both silver and foil types.

Since the quality of mica capacitors depends upon the quality of the mica — and this means careful inspection and manufacture — an occasional poor product may come from well-qualified vendors. In general, however, both silver and foil micas are satisfactory when properly manufactured, properly inspected, and properly used.

## CERAMIC CAPACITORS

A relative newcomer to the electronics field, ceramic capacitors consist essentially of a ceramic dielectric with metallic electrodes intimately bonded by firing at an elevated temperature. This type of structure is very versatile; units can be tailored physically and electrically so that a large variety of configurations and characteristics are possible. Ceramics now exist in tubular, disc, stand-off, and feed-through types. They are of the general purpose type or their varying temperature coefficients may be used for compensation purposes.

Temperature Characteristics. The dielectric constant of the material employed is under control of the manufacturer, who can produce dielectrics of very high dielectric constant, making possible high capacitance in small volume. The higher the dielectric constant, however, the greater the temperature sensitivity of the completed unit. The following gives an idea of these factors.

## Ceramic capacitors /27/

Maximum capacitance change from 25 C value (percent)				
Dielectric constant (K)	Temperature (C)			
	-55	-40	+65	+85
1,200	-10	-7.5	-7.5	-10
1,700	-20	-15	-15	-20
3,500	-70	-60	-35	-60
6,000	-90	-80	-45	-65

Therefore, a capacitor incorporating a K=1,200 material may provide a higher minimum value over a wide operating temperature range than a unit of identical size incorporating K=6,000 material. For example, a 5,000 mmfd, K=6,000 capacitor and a 1,000 mmfd, K=1,200 capacitor (identical in size) would provide, at -55 C, 500 mmfd and 900 mmfd, respectively.

The materials with dielectric constants greater than 2,000 are also more limited in operating voltage gradient and, therefore, do not provide as much size advantage in higher voltage capacitors. Aging rate generally increases as dielectric constant is increased. Therefore, while the high dielectric constant capacitors find wide application within their limitations, the designer should appreciate that, as with all other components, size advantage is inherently coupled with performance restrictions.

**Temperature-Compensating Series.** This series covers a range of temperature coefficient of capacitance from +100 to -5,600 parts per million per °C. These capacitors are characterized by high Q, high insulation resistance, and excellent moisture resistance and aging stability. Standard capacitance tolerances range from ±1 percent or ±0.1 mmfd (whichever is greater) to ±20 percent.

Capacitance values range from about 1 to 5,000 mmfd, depending upon size, temperature coefficient, and voltage rating. The standard working voltage is 500 volts dc, but ratings as high as 6,000 volts are available.

**General Purpose Series.** This classification is a very broad one, covering types intended for use in circuits where power factor is not critical and where moderate capacitance changes caused by temperature variations and aging do not impair circuit operation. This classification includes capacitors employing high dielectric constant materials that provide large capacitance ratings per unit volume over a restricted temperature range. These capacitors may be operated over a temperature range of from -55 C to +85 C. This classification also includes capacitors of the same type and characteristics already described under the temperature-compensating classification, except that capacitance and temperature coefficient tolerances are broader.

Standard capacitance values range from about 5 to 18,000 mmfd at a working voltage of 500 volts dc.

Common capacitance tolerances are ±10 percent, ±20 percent, and GMV (guaranteed minimum value). Voltage ratings as high as 6,000 volts dc are available over a more limited capacitance range. Ratings up to 30 kilovolts are also available for specialized applications.

It is not feasible to publish sufficiently detailed performance characteristics to cover all applications of these capacitors. For example, voltage and current ratings at radio frequencies cannot be stated concisely because of their dependence upon such related factors as capacitance, power factor, operating frequency, and d-c bias. For this information, and for information concerning critical performance requirements or unusual operating conditions, the circuit designer should consult a reputable manufacturer.

**Ceramic Trimmer Capacitors.** These consist essentially of a disc-type ceramic rotor and base, the mating surfaces of which are lapped to optical flatness. Electrodes are fired onto both parts so that capacitance may be changed by varying the amount of overlap. Capacitance change per degree of rotation is approximately constant. Standard styles are available with temperature coefficients of capacitance ranging from zero to -650 (±200) parts per million.

These trimmers show excellent stability over a wide range of operating conditions. A maximum operating temperature of 85 C is recommended. Operating temperatures as high as 125 C are possible, but consultation with the manufacturer is advisable.

Typical capacitance ranges vary from 1.5 to 7 mmfd as a minimum to 8 to 50 mmfd as a maximum, depending upon dielectric and style employed. Voltage ratings as high as 500 volts dc are available. Q at 1 megacycle is 500 minimum.

The following precautions should be observed during handling and assembly to prevent unnecessary impairment of performance of these capacitors.

1. Keep in original container until used.
2. Exercise reasonable care during handling to avoid breakage of the ceramic dielectric.
3. Avoid contamination from perspiration, excess soldering flux, and so on, as such materials may promote corrosion and, hence, lead to premature failure in service.

## BUTTON MICA CAPACITORS

The button or disc mica capacitor is a small, high-quality unit intended primarily for operation in v-h-f and u-h-f ranges. It is composed of a stack of circular silvered mica sheets firmly encased in a metal housing. The high potential terminal is connected through the center of the stack, while the other terminal contacts all points around the outer electrodes. This compact coaxial design minimizes the electrical path length between center terminal and chassis. The use of relatively heavy and short



terminals results in minimum overall inductance. This type of capacitor, therefore, is well suited for v-h-f and u-h-f applications.

This is a high-stability, low-loss capacitor. The design makes possible a wide variety of mounting styles and terminal arrangements, many of which are standard. Available capacitance values range from 15 to 8,100 mmfd (refer to Table 8-7), with tolerances as close as  $\pm 2$  percent. Maximum working voltages are 350 volts ac, 500 volts dc. The standard maximum operating temperature is 85 C, although special types are available for operation up to 125 C.

While this capacitor will withstand considerable abuse, like the ceramics it must be handled with proper care. Thus:

1. Keep capacitors in original container until used.
2. Insofar as possible, avoid distorting shell and terminals during handling and assembly operations.
3. Do not disturb seal.

4. Solder as quickly as possible to minimize overheating of the seal.
5. Avoid contamination from perspiration, excess soldering flux, and so on.

Silver Migration. During the Navy-Bell Laboratories program, 152 silver mica capacitors were returned for inspection. Of them, 128 had low insulation resistance, and of these, 119 had a "migrating conduction path." It has been rather firmly established that silver, or silver-plated materials, in contact with organic insulating materials in presence of d-c potentials and moisture is prone to trouble from "silver migration." Studies continue on this program to find a long-range solution.

Migration does not occur if the applied potential is alternating rapidly enough. Moisture, unipolar potential, and time seem to be the essential ingredients of this trouble, which causes colloidal silver chains to form through the insulation (especially in reinforced phenolics), causing a blackening of the insulation, followed by great reductions in dielectric strength, by lowering of insulation resistance, and often in the failure of the unit. /28/ /29/

Table 8-7. Capacitor characteristics

Characteristic	Ceramic capacitors		Button mica capacitors	
	Temperature compensating	General purpose		
Capacitance range (mmf)	min max	1 5,000	5 18,000	15 8,100
Tolerance (percent)	min max	$\pm 1$ $\pm 20$	$\pm 10$ -0, +100	$\pm 2$ $\pm 20$
Dielectric constant	min max	10 800	100 6,000	6.0 7.0
Voltage range	min max	350 6,000	350 6,000	350 ---
Temperature coefficient (ppm per °C)	min max	+100 ( $\pm 30$ ) -5,600 ( $\pm 1,000$ )	-330 ( $\pm 500$ ) $\pm 15,000$	-20 +100
Temperature range (°C)	min max	-55 +125	-55 +125	-55 +125
D-c leakage resistance at 25 C (megohms)		10,000 min	10,000 min	10,000 min
Power factor at 25 C (percent)		0.1 (at 1 Mc)	2.5 (at 1 Kc)	0.07 (at 1 Mc)

Specifications. The following JAN or MIL specifications control the purchase of various types of capacitors at the present time.

Capacitors, Air-Dielectric, Variable (Trimmer Capacitors)	JAN-C92(5)
Capacitors, Bypass, Suppression (Radio-Frequency Interference)	71-1667(1)
Capacitors, Ceramic-Dielectric, Variable	JAN-C-81(2)
Capacitors, Dry-Electrolytic (Aircraft Grade)	71-1116
Capacitors, Dry-Electrolytic, Polarized	JAN-C-62(4)
Capacitors, Fixed, Ceramic-Dielectric (General Purpose)	MIL-C-11015A(1)
Capacitors, Fixed, Ceramic-Dielectric (Temperature-Compensating)	JAN-C-20A(6)
Capacitors, Fixed, Electrolytic (AC, Dry-Electrolytic, Nonpolarized)	MIL-C-3871(1)
Capacitors, Fixed, Electrolytic (AC, Dry-Electrolytic, Nonpolarized), Style CJ72	MIL-C-3871/1
Capacitors, Fixed, Glass-Dielectric	MIL-C-11272A
Capacitors, Fixed, Glass-Dielectric, Style CY 10	MIL-C-11272/1
Capacitors, Fixed, Mica-Dielectric, Button Styles	MIL-C-10950A
Capacitors, Fixed (Paper- or Mica-Dielectric)	32412-B
Capacitors, Fixed, Mica-Dielectric (with Supplement No. 1 dated 24 March 1953)	MIL-C-5A(1)
Capacitors, Fixed, Paper-Dielectric, Direct-Current (Hermetically Sealed in Metallic Cases) (with Supplement 1A dated 7 July 1953)	MIL-C-25A(1)
Capacitors, Fixed, Paper-Dielectric (Nonmetallic Cases) (with Supplement No. 1 dated 13 April 1953)	MIL-C-91A
Capacitors, Electrolytic, Tantalum, DC, Foil Type and Slug Type	MIL-C-25102

## CONNECTORS /30/

Electrical connectors have become so essential in the construction of electronic equipment that they must receive the closest attention at design and in later maintenance operations if a high order of reliability is to be realized. The timesaving advantages of sectionalized manufacture and plug-in assembly are lost if the connectors develop faults of any kind. In maintenance, the use of connectors on electrical and electronic equipment permits quick removal and replacement of critical units, so that a minimum of operating time is lost. Such maintenance is performed at top speed, usually, and without regard for any lack of ruggedness in the connection device. Hence, mechanical reliability is as important as electrical integrity.

Electrical Considerations. Generally, the first consideration in design or in changes made in connectors during maintenance replacement is electrical. Connectors are designed to carry specified maximum current at specified maximum voltage per contact, and there should be no trouble either with overheating or with electrical breakdown so long as those ratings are not exceeded. The AN family of connectors is probably the most widely used group in electronic and control apparatus. Specification MIL-C-5015, which covers them, is specific with respect to both current and voltage ratings for the contacts. Table 8-8 shows the voltage and current maximum rated values for all of the standard AN types.

In the AN Series, the contact sizes are given in terms of the maximum wire size that can be accommodated by the solder cup at the rear end of the contact. Actually, the size 20 and size 16 contact pins have the same diameter at the forward end — 0.0625

inch nominal, but the solder cup end of the size 20 contact will accept nothing larger than a size 20 wire and is smaller in diameter than the corresponding cup on the size 16 contact. All of the other contact sizes increase in diameter with each step down in designating number, just as is the case in wire sizes.

The efficiency with which current is passed between a pin and its mating socket contact is measured in terms of the millivolt drop through the pair of contacts.

The safe voltage rating for connectors in the AN Series is established on the basis of service application, with the lowest value applied to connectors for instrument use in which both the voltage and current will be low. Here, the only mechanical requirement is that the creep distance across the insulation between contacts must be at least 1/16 inch. The "A" 1/16 inch as the closest spacing through air between contacts is the most common class within the series.

Catalogs published by the manufacturers of AN connectors and the AN insert drawings issued by the Aeronautical Standards Agency for the Armed Services show the contact sizes and the service rating for each connector. If these documents are not available, and connectors are on hand, it is a simple matter to determine the safe current and voltage operating conditions by comparing contact pins with known wire sizes and by measuring the contact spacing at the solder cup end of the connector. Ultimate equipment reliability can be assured by remaining within the specification ratings for current and voltage as shown in Table 8-6.

Table 8-8

Current and voltage ratings assigned to AN connectors  
under Specification MIL-C-50515B

Current rating contact size amperes	20	16	12	8	4	0		
	10	22	41	73	135	245		
Service			inst	A	D	E	B	C
limiting operating	DC		250	700	1250	1750	2450	4200
voltages at sea level (see notes 1 and 2)	AC		200	500	900	1250	1750	3000

1. Transients were not considered in calculating these values.
2. Limiting operating voltages at 50,000 feet altitude are approximately 25 percent of the sea level values.

The materials used in the manufacture of the AN Series connectors are constantly being improved in an effort to improve reliability. Contacts, which originally were brass, are now made almost entirely of bronze alloy to ensure good spring quality along with good conductivity. They are heavily silver plated, and one manufacturer has added gold over the silver as a further step to assure excellent electrical contact between mated units. The dielectric insulation, steadily improved in the past ten years, is now required to be stable dimensionally throughout a long service life, as well as superior in electrical qualities in the presence of high relative humidity and elevated temperatures. The new diallyl phthalate resin molding compounds are replacing shrinking melamine under the B revision of MIL-C-5015 to add to the dependability of these electrical connectors.

The aluminum connector shells are now required to be cadmium plated and chromate conversion coated for increased corrosion resistance and improved electrical conductivity, and also for better radio shielding.

All of these steps have made the potential reliability of electrical connectors greater than before. Yet the final achievement of reliability still rests with the technician who is responsible for the soldered connections which join the cables and their conducting wires to the connectors.

**Soldering.** Soldering technique has much to do with reliability. An excess of solder can cause trouble of several types. Any solder outside the solder cup on a contact reduces the air spacing between contacts and lowers the breakdown potential between contacts. Also, excess solder runs back into the strands of stranded conductors, making them more vulnerable to vibration breakage than would be the case when the application of solder is limited to the contact solder cup and the conductor immediately inside it.

It is essential that only noncorrosive solder flux be used in assembling connectors to wiring harnesses. Rosin core solders are satisfactory. Paste type fluxes should never be used. The cor-

rosion resulting from the use of an improper flux may take months to develop, or it may not appear until the connector has been exposed to high humidity for several weeks. By that time, the connector may be part of a complex assembly, the operation of which can be ruined by leakage through corrosion products between contacts.

**Moisture-Prevention Techniques.** During World War II and for several years thereafter, the Armed Services required that connector assemblies be packed with silicone grease to prevent the entry of moisture or any other contaminating material. That practice has now been discontinued because of the tendency for the silicone grease to pick up dust and dirt and because of an apparent reaction between the grease and ethylene glycol derivative type hydraulic fluids used on aircraft. It has been found that maximum reliability is achieved by utilizing insulation unaffected by periodic exposure to high humidity. The adoption of diallyl phthalate dielectric materials fulfills this requirement.

For applications which involve exposure to very severe moisture conditions, the E-class connectors in the AN Series may be used, or the standard types may be employed with all open sections filled with potting compound. Thiokol rubber is one of the pourable compounds now employed for this purpose. The potting technique can be utilized with any type of connectors that have a backshell or are designed so that a casting enclosure can be formed around the solder terminals.

Where the E-type AN connectors are used to exclude moisture, great care must be taken in assembly to avoid entrapment of moisture carried into the connector by capillary action through imperfectly sealed resilient interface surfaces.

Where a resilient backing grommet is used in the E-type AN connectors to enclose the individual contact solder cups and conductors at the rear of the connector insert, great care must be taken to pull all conductors through the grommet simultaneously as the grommet is pushed forward against the

back of the connector insert. Failure to do this will cause kinking of one or more conductors ahead of the grommet and can cause shorts between contacts or failure of the backing grommet to seat and seal against the back of the connector insert.

Another essential precaution with the E-type AN connectors, where used, is the maintenance of correct contact positioning, particularly in the pin contacts when the wired connector is finally assembled. Twisting of the backing grommet or of the conductor bundle by the cable clamp can cause the contacts at the front of the connector to spew or skew out of position so that they will not enter the mating connector contacts correctly. Pin-style, E-type AN connectors should be checked carefully for this problem before wiring assemblies are released from inspection.

Hermetically sealed connectors are available in many forms. The true hermetic seals are of the fused type, in either glass or ceramic, and all have shells that can be solder-sealed to the equipment containers on which they are used. For maximum reliability, the limit of applied voltage must be established on the length of the leakage path between contacts. Where individual glass seals are used, the width of metal between the seals must be subtracted from the creepage path distance in determining the real creep distance and from it the true voltage rating.

The connectors discussed so far have been units covered by Specification MIL-C-5015B or that mate with them, such as the sealed types.

A large number of other connectors used within and external to electronic equipment are covered by Air Force Specification MIL-C-8384 (USAF). The same care in selection for application must be exercised with these units as has been outlined for AN connectors if full reliability is to be achieved.

The voltage ratings of Table 8-7 apply, and the proper rating for a given connector is readily determined by checking the spacing and the creep distance across the dielectric between the contacts. Current ratings are established on the basis of contact cross section area and, in any event, should not exceed the values listed in the specification.

The small hex-shaped connectors covered by MIL-C-8384 (USAF) use contact pins with a diameter of 0.040 inch that will safely handle up to 5 amperes. They are widely used within equipment to connect subassemblies that may be removed as units for servicing.

Ribbon-type connectors are employed principally in rack and panel construction where the low insertion and withdrawal force provided by the ribbon contacts simplifies installation and servicing of rack-mounted units. They are available in a variety of contact combinations and styles between 8 and 32 contacts.

Pin and socket connectors are used chiefly within equipment for subassembly connection and are available in a wide variety of contact numbers and styles.

R-F Connectors. These connectors must maintain electrical continuity and at the same time preserve the impedance characteristics of the cable with which they are used. The match between connector and cable becomes more important as the frequency increases, and begins to be critical consideration above 100 Mc.

The u-h-f type of connector, widely used below 100 Mc, does not incorporate the constant impedance design built into other plugs. No provision is made, for example, for continuation of the cable shield through the plug without change in diameter. The contact pin has a much larger diameter than the cable center conductor.

Class C plug is a typical constant impedance unit. In use, care must be taken to see that the cable dielectric is firmly seated against the dielectric insert within the connector body. Any air gap at this point will produce an impedance discontinuity that will be serious above 100 Mc.

Care in assembly of r-f connectors to r-f cables is a basic ingredient of reliability, just as it is on all other connectors.

## TRANSFORMERS, R-F COILS, AND INDUCTORS

Transformers. The Bell Laboratories-Navy Component Reliability Program/2/ indicated that manufacturing defects and operating conditions accounted for about half each of the total number of failed transformers examined in the Laboratories. /31/ Manufacturing defects consisted of nicked wires, which caused open circuits; absence of sleeving and required insulation; poor potting; use of corrosive soldering flux; and poorly soldered seams. Better inspection and control of the manufacturing operation would eliminate most of these troubles. Failure in operation was largely in burned-out coils, usually resulting from the failure of some other component. The use of fuses or circuit breakers would have prevented such transformer losses.

Transformer Corona Test. Use of an oscilloscope for revealing presence of corona in filament and plate transformers is given in the DuMont Oscillographer, July 1954, as developed and employed by the New Jersey Electronics Corporation.

The transformers under test for corona discharge are subjected to a voltage based on the transformer working voltages. The circuit in Figure 8-51 tests the intrawinding insulation; that in Figure 8-52 tests interwinding insulation and the insulation between winding and ground. Both employ a DuMont Type 304-A oscillograph. Filament transformers are subjected to the test performed by the circuit in Figure 8-52 only, while plate transformers get both tests. Presence of corona is made evident by r-f oscillations superimposed on the basic sine wave.

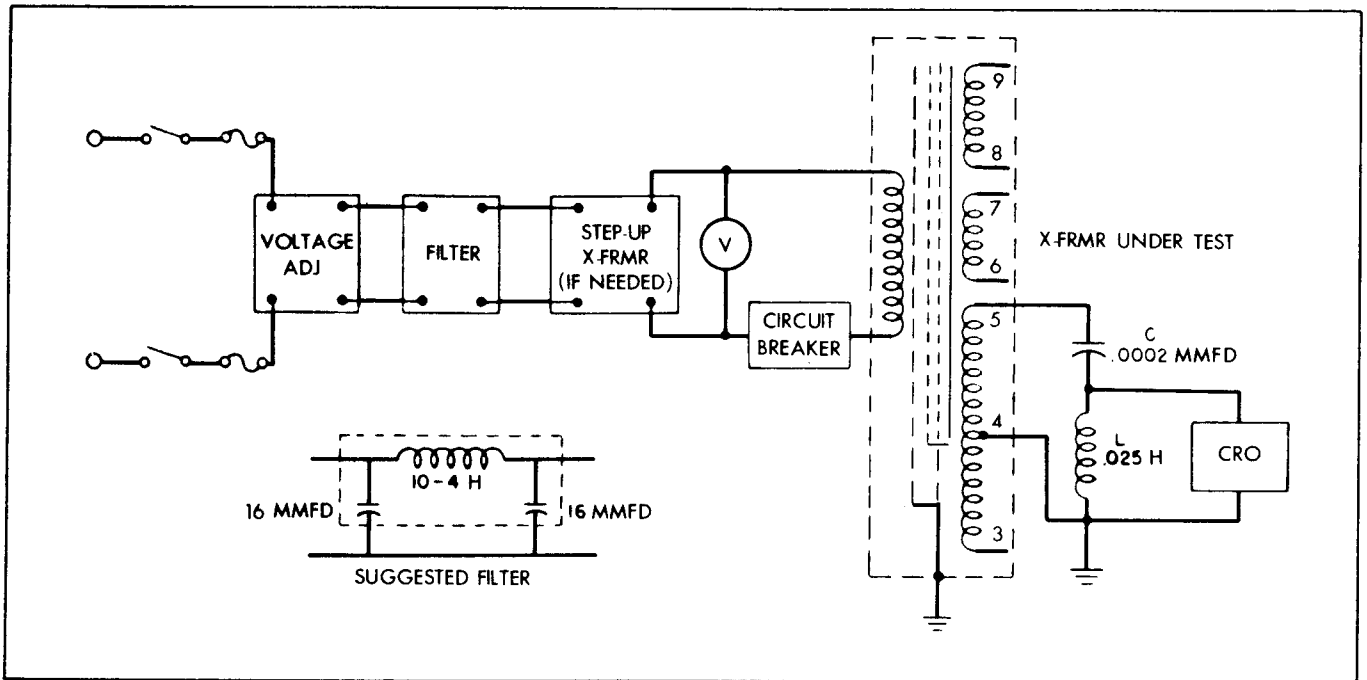

Figure 8-51. Circuit used primarily for corona-discharge tests of transformer intrawinding insulations

The tests themselves consist in connecting the transformers in either or both circuits and gradually raising the voltage up to the limit specified in the specification. The test voltage applied varies according to the working voltage of the transformer. When the voltage is to be above 700 volts, the specification formula for acceptance voltage is

$$V = 30\% (1.4 \times \text{working voltage} + 1000)$$

The specifications require that the oscillograph be sensitive enough to produce a signal 1 inch in amplitude for a 0.1 volt peak-to-peak input and the Type 304-A satisfies this requirement.

**R-F Coils.** The literature on inductors of various types of winding for various frequency ranges is voluminous, and it is surprising to discover that "Engineers have been known to disregard completely such inductor considerations as distributed capacitance and external field, and to expect unrealizable inductances and Q's for impractical sizes." /32/

Only a few sources need to be investigated to learn a great deal about the distributed capacitance and Q of the several types of winding and at the same time to be able to gather a considerable bibliography on the subject. /33/

**Distributed Capacitance.** This characteristic of all coils increases the equivalent inductance and resistance when operated at frequencies below the natural frequency of the coil and, of course, restricts the tuning range with a given variable capacitor. The effect is most pronounced at the high frequencies, where the tuning capacitance is small. For practical solenoids the values of distributed

capacitance will run from 10 to 13 for the long-wave region of the spectrum, from 3 to 7 for medium wavelengths, and from 2 to 5 for short waves.

Medhurst /34/ gives the following formula and states that it gives values within 5 percent of the true capacitance.

$$C_d = HD \text{ (mmfd)}$$

where D is the diameter of the coil in cm

H varies as the ratio of coil length to diameter as shown below

L/D	H
50	5.8
25	2.9
10	1.32
5	0.81
2.5	0.56
1	0.46
0.5	0.5

The capacitance may be measured simply by finding the capacitance required to tune the coil to a given frequency, f, and for twice this frequency, 2f. Then

$$C_d = \frac{C_f - 4C_{2f}}{3}$$

If the coil is attached to its circuit by long leads, the effective distributed capacitance will be increased by the capacitance of the hot lead to ground. A single No. 20 SWG wire has a capacitance of 0.215

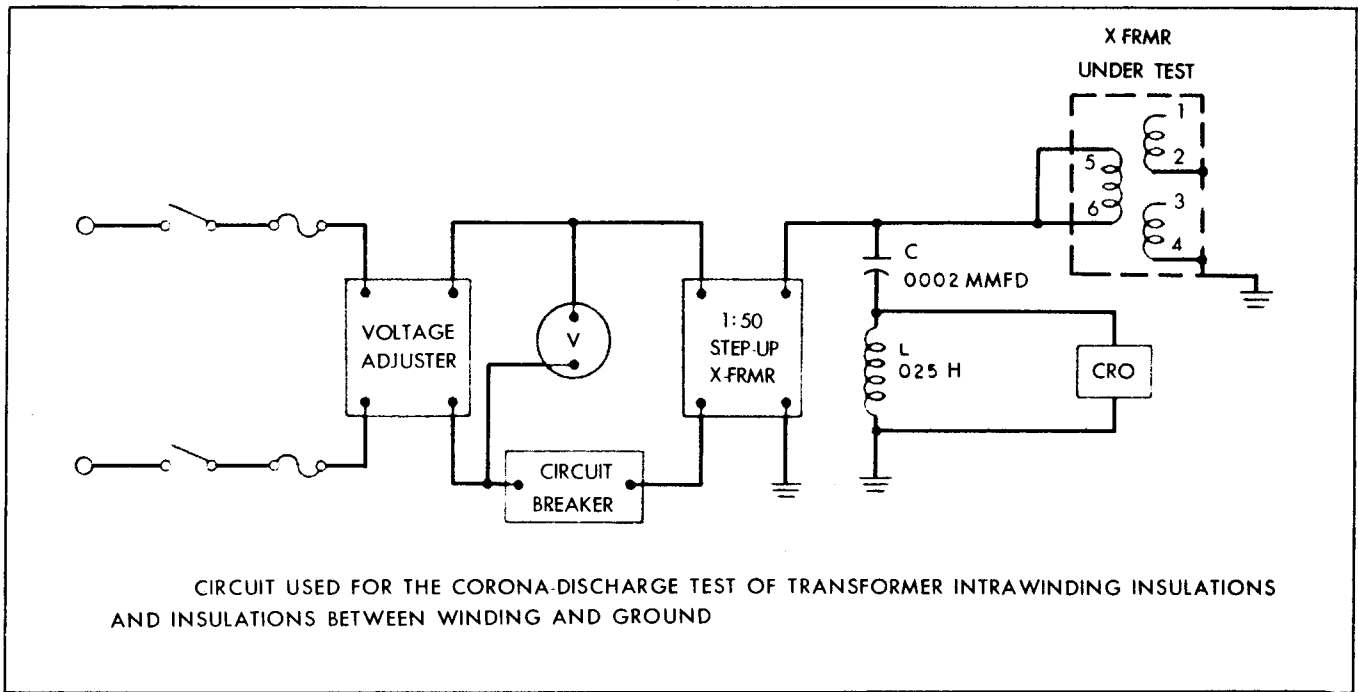

Figure 8-52. Circuit used for the corona-discharge test of transformer intrawinding insulations and insulations between winding and ground

mmfd per inch; a No. 12 SWG wire has a capacitance of 0.28 mmfd per inch. The lead capacitance must be added to the distributed capacitance of the coil to determine the total effective coil capacitance.

A formula Medhurst gives the capacitance as follows:

$$C_d = 5.08 r \left[ 0.0563 \left( \frac{\ell}{r} \right) + 0.38 \sqrt{\frac{r}{\ell}} + 0.08 \right] \text{ mmfd}$$

where  $r$  and  $\ell$  are the radius and length in inches.

Thus, a 350- $\mu$ h coil with 1-inch radius and  $1/r$  of 2 has a capacitance of 2.34 mmfd.

**Effect of Shielding.** Putting an r-f coil in a shield has the effect of putting a short-circuited turn of wire around the coil. The shield acts as a secondary of a transformer, reflecting into the coil an impedance that is the equivalent of a resistance and a negative inductance. Thus, the resistance is increased, the inductance is decreased, and  $Q$  goes down. If the radius of the coil is equal to or less than one-half the radius of the shield, not too great a drop in  $Q$  will occur.

Any material in the field of the coil will absorb energy and increase the resistance of the coil. Insulation that may absorb moisture should not be used.

**Selection and Specification of R-F Coils.** In addition to the basic parameters that outline the normal characteristics of r-f coils and transformers, the manufacturer of the units must know the following factors: /35/

#### Environment — operation and storage

1. Temperature
2. Humidity
3. Vibration and shock
4. Salt spray or other atmosphere
5. Weather protection required
6. Altitude
7. Any other unusual environmental condition, such as blowing sand.

The effects of these factors upon the inductors are as follows:

**Temperature** — may cause warping, melting, binding, change in dielectric properties, cracking, and change in frequency stability.

**Humidity** — rusting, electrolysis, seizing, changes in conductivity, electrical leakage, voltage breakdown, loss of  $Q$ , loss of circuit sensitivity, and change in bandpass characteristics.

**Vibration** — loosening or breaking of parts, leads, and connections, detuning, loss of sensitivity.

**Salt Spray** — similar to humidity but much more severe.

**General Considerations.** If circuit stability is important, as in an oscillator or discriminator, so that small changes in inductance or capacitance cause large or important changes in operation.

1. Use as large a capacitance as practicable, but maintain a reasonable inductance.

2. If L and C are such that slight changes in value cause large changes in frequency or other parameter, then all components must be selected for best stability, the mechanical assembly must be rigid, and hermetic sealing is advisable.

The designer must determine that all proposed parameters are compatible, that is, that such things as bandwidth, Q, and coupling are interdependent, and that one factor cannot be specified without recognizing its effect on the other factors.

The original designs and the experimental setup should be made with nominal components, but the effect of using other inductors, that is, those of normal manufacturing tolerances, must be determined. Among other things, the mechanical fit of the parts is as important as the electrical characteristics. The tuning range of a tuned transformer, for example, is often ignored or is specified without allowance for manufacturing requirements.

## RELAYS

The Vitro study indicated that out of a total population of 20 million components, there were 135,000 relays, and that of the failure reports studied, about 1,000 relay failure reports were investigated. During the same period, 15,547 relays were issued as replacements. About 20 percent of the failures were attributed to open coils and about 11 percent to unstable operation. The other relays failed for other reasons but in small percentages.

The greatest number of failures among the 82 relays investigated by the Bell Laboratories were due to open contacts because of poor adjustment, dirt, or bent contact springs. Open coils accounted for 15 percent of the 82 relays returned to the Laboratories for study.

It is not surprising that relays fail in military service, but it is surprising that so few fail, when one considers the number used, their complexity, and the severe conditions of use. Much work is being done to improve the reliability of relays and to inform engineers of their proper use. Reduction in the total number of types or models required by the military designers would relieve the situation greatly. Lack of information of what relays do under varying environmental conditions is probably the greatest single cause of relay trouble. "Unlike the simple capacitor or resistor the relay is more prone to failure because of its intricate electrical and mechanical design." /36/

The many electrical and mechanical factors of relay design, manufacture, and use are so interrelated that it is difficult as yet to set down anything but the bare ground rules for proper usage. Sumner points out the antagonism that exists between such requirements as high coil resistance (for use in tube plate circuits) and space (which limits the insulation that may be used). These requirements work against each other. It is possible that a relay designed for lower temperature operation will last

longer at elevated temperatures because the lower temperature unit may have better insulation.

The problem of contact arcing, with consequent pitting and corroding contact welding, is being studied, and there is considerable empirical data in the literature. The use of resistive-capacitive filters and dry rectifiers in reducing arcing troubles is well-known, but the final word has not yet been said on these and other techniques.

The simple fact that some relays resist vibration better when mounted or supported in one direction rather than in other orientations is often overlooked. This happens because other mechanical factors entering into the mounting problem are more apparent at the design and manufacturing stage. Convenience or available space usually control where and how the relay will be mounted. Sumner /36/ gives some useful data on proper orientation of telephone-type, plunger-type, and rotary-type relays.

There is, as yet, no satisfactory definition of the end of life for a relay. If it is supposed to last through 40,000 operations, does this mean that the armature falls off or that its contacts will be welded together at the end of this period?

Considerable information will be found in the proceedings of the Symposium on Electro-Magnetic Relays. Here it was pointed out that most of the standard relays stand up under high- and low-temperature conditions; that sensitive relays fail most often at high temperatures; that moisture troubles are very prevalent because of electrolysis; that impurities from the hands — perspiration and natural oils — or from the atmosphere in which the relay must function cause many troubles; and that at moderate temperatures the buildup of contamination is so slow that little trouble can be expected, while high temperatures — due to ambient temperature or due to heavy currents in the leads or at the contacts — cause much faster contamination buildup.

Relay Contact Arc Suppression. When the contacts of a relay open, the area of contact carrying the current decreases, thereby increasing the current density, increasing the power that must be dissipated in small area, and increasing the heating effect accordingly. If an arc forms, as evidenced by a colored discharge (blue-green or blue), it is evidence of ionized metal. This indicates that some of the contact metal has melted. In time, the contacts become pitted, the contact area becomes limited, and the contacts may be welded together by the generated heat.

Contact arcing should not be permitted, not only for the reason cited above, but because it produces transients, if the load is inductive, creating radio interference. In addition, the high negative overshoot voltage occurring at contact break in an inductive circuit may produce voltages high enough to ruin the insulation and cause breakdown. When the inductive load is opened, the current continues to flow for a short time, either across the gap or through the stray capacitance, or both, and may produce as much as 1,000 volts, even if the relay is a small one.

The current continues to flow until the contact gap finally is great enough to break the circuit. Speed and length of contact break have a bearing on the length of time the current flows. High-speed opening reduces the time. Thus, double-break contacts halve the time the arc flows, other considerations being equal.

R-C Suppression. A capacitor across the contacts or across the load will reduce the voltage at the moment the contact break occurs; but this capacitor will look like a dead short when the contacts close, so that a heavy inrush of current occurs. To limit this current inrush, resistance may be added in series with the capacitor. The value of resistance should be as small as possible; the capacitor should be as large as possible. The following formulas are taken from Engineering Note E-401 of the Servomechanism Laboratory, MIT, which contains considerable material on this subject.

If the load is inductive, then the R-C circuit should make the load look like a pure resistance to the contacts. In general, the resistance should be of the order of 1/2 to 1/4 the load resistance. To make the load look like a resistance

$$RC = \frac{L}{R_L}$$

where L is the inductance of the load and  $R_L$  is the load resistance. Thus, it will be necessary to know the load inductance. If this load consists of small relays having an operating speed of from 5 to 15 milliseconds, the 60-cycle inductance will be sufficiently accurate to calculate the value of C above.

To determine the inductance, use a variable autotransformer to furnish power to the relay coil, measure the current through the coil and the voltage across it when the relay just pulls-in. The inductance at this point is what is wanted and may be found from

$$L = \frac{\sqrt{Z^2 - R_L^2}}{377}$$

where  $Z = \frac{E}{I}$  and  $R_L$  is the relay coil resistance measured by an ohmmeter.

If, now, R is chosen as  $\frac{R_L}{4}$ , the required capacitance may be found from

$$C = \frac{4L}{R_L^2}$$

If this capacitance value is unreasonably large, a smaller value will have to be used, but the value of R will have to be increased. If an electrolytic capacitor is used, choose one with a voltage rating near the supply rating, so that its capacitance will be correct. An examination of the situation with an oscilloscope is desirable at this point to determine if sufficient arc suppression has been accomplished and if reverse voltages in excess, say, of 10 percent of the capacitor rated voltage are being applied to the capacitor. Electrolytics heat up if the reverse voltages applied are much above this value. Usually,

an adjustment of the resistance employed in the R-C circuit will conclude the job.

Note that these are optimum values of R and C. The capacitor may be increased in value, but no increase in suppression is obtained, and a decrease in relay release time or decrease in voltage decay across the inductive load will result. The increase in release time may be judged by the approximation that it is equal to the time constant RC.

Arc Suppression by Rectifier. A nonlinear resistance, such as a selenium or copper-oxide rectifier, may be employed to suppress arcs. This is simpler than the use of RC combinations, although not capable of such complete suppression, since its characteristic does not change until some reverse voltage has built up. Thus, the negative voltage produced at the moment of contact opening in an inductive circuit is not completely suppressed.

Selenium rectifiers may be subjected to considerable overload for short periods without damage. The rectifier current rating may be chosen as 1/10 the load current if the duty cycle of the load (relay) is low and 1/4 the current if the duty cycle is high. The rectifier may be soldered directly across the coil terminals of most relays.

If the chief trouble is an inductive load, and other factors are unimportant, use a rectifier; if such matters as relay timing, high current, small contacts or low melting-point contacts are important, then use R-C suppression.

Unless there are other reasons for placing the suppression circuit or rectifier across the contacts, suppression should take place at the load. Arc suppression at the contacts interferes with resistance continuity checks and makes the circuit more difficult to trouble-shoot.

#### VIBRATOR SELECTION AND USAGE/37/

In approaching the designing of vibrator power supplies, the most essential factor for the designer to keep in mind is that a vibrator mechanism is essentially a vibrating switch, designed and constructed to operate automatically at a predetermined frequency by electromagnetic action. The operation and functioning of this switch is fixed by the vibrator manufacturer to obtain the most reliability and longest life possible.

Vibrator Operation. In operation, there is a definite time interval between the opening of one set of contacts and the closing of the opposite set of contacts. This produces a discontinuity in the waveform, during which time the applied voltage is reduced to zero. The ratio of the "on contact" time to the total time is referred to as the time efficiency of the vibrator and is established by the design of the vibrator mechanism itself in order to produce the expected reliability and long life. If this time efficiency is too low, there will be a resultant reduction in overall power efficiency and output of the system. If this time efficiency is too high, the accumulation of small variations that occur in the manufacture of the vibrator and those that arise from normal wear



result in excessive fluctuation of operating performance. Thus, a vibrator mechanism must be considered in the same relationship as a tube, and it must be recognized that the vibrator manufacturer cannot make a variation in time efficiency to increase or decrease the output of the circuit without affecting the life and reliability of the vibrator. Any changes in output must be done in the transformer design by obtaining the proper turns ratio at the time the circuit is designed. Since various mechanisms being manufactured today will vary from 70 percent to 90 percent time efficiency, it is essential that the designer consider all of his potential sources for vibrators and be sure that his circuit is designed to permit the tolerances of output that will result from the various time efficiencies of the mechanisms being considered.

Waveform Considerations. The basic difference between a vibrator power supply system and that of an a-c source lies in the shape of the voltage waveform produced. The output of a rotating a-c generator has a waveform essentially that of a sine wave in which the instantaneous value of voltage is continuously varying and in which no discontinuities appear during the complete cycle. The output of a vibrator system has a rectangular-shaped wave in its ideal form and a somewhat trapezoidal shape of wave in its practical use. The designer must bear in mind the difference in rms and average voltage and currents between these two wave shapes in order to design his circuits and transformers to have the proper wire sizes and so forth. In addition, it can be recognized that it is necessary with the steep current wave front associated with the vibrator power supply system to use a power source that is capable of delivering high demand current, or the output of the system will be affected accordingly. Also associated with the vibrator power supply system is the making and breaking of the contacts that produce transient voltages. The designer must be cognizant of these high transients in order to provide sufficient insulation in his transformer and timing capacitance of sufficiently high voltage rating to withstand these continual transient conditions.

Timing Capacitance. Practically all vibrator power supply systems have a vibrator working in the primary circuit of a transformer, the primary of which is center tapped and so connected that the flow of current controlled by the vibrator will produce an alternating magnetic flux in the core. Since this transformer is an inductive load connected to the d-c circuit through the vibrator contacts, high induced voltages would be generated at each make and break of the contacts, unless some means of control is provided. These high induced voltages, if not controlled, would not only cause a breakdown of the insulation, but also would result in severe arcing of the vibrator contacts and thus shorten the life of the vibrator.

To control these high induced voltages during the vibrator "off contact" interval, it is necessary to connect a capacitor of proper value across one of the transformer windings. This value of capacitance combines with the effective inductance of the transformer winding to form a tuned circuit, which is set

in shock oscillation at each opening of the contacts. By properly selecting the value of capacitance to match the transformer and vibrator characteristics, the resulting oscillation can be made to perform the useful function of reversing the induced voltage, making it coincide with the voltage applied to the transformer by the closing of the vibrator contacts on the succeeding half cycle.

The value of this timing capacitance is very critical and must be selected with particular care in regard to both the circuit and the vibrator mechanism. This interdependence of the vibrator, transformer, and timing capacitor in producing satisfactory performance and good vibrator life is the basis for the general recommendation that all vibrator power supply design data, including the components themselves, be submitted to a vibrator manufacturer for analysis and approval before the vibrator is approved for use in the power supply.

Suggestions for the Equipment Designer. The following suggestions should be of material value in vibrator power supply design.

1. The buffer or timing capacitance can be placed in the circuit in either the primary or the secondary side of the transformer. If it is placed in the secondary side, its capacitance is reflected in the vibrator portion of the circuit by the square of the turns ratio of the transformer. The common procedure is to place the capacitor in the secondary side in order to utilize a capacitor that is small both in capacitance rating and physical size. In some cases, where the power supply is to produce either an abnormally low voltage or an extremely high voltage, it is desirable to use a tertiary or "buffer" winding to enable the designer to utilize a capacitor of more practical capacitance and voltage rating than would be possible if such a winding were not used. When such a winding is used, the designer must recognize the square wave that is being dealt with and allow sufficient current-carrying capacity in the tertiary winding to handle satisfactorily the current that will flow in this buffer circuit.
2. In designing circuits for use with 12-volt or higher power sources, a phenomenon that is not prevalent in six-volt circuits is encountered. This is described as a "starting flare" characteristic of the vibrator. This results from a saturation of the transformer on the start cycle of the vibrator, thus drawing an abnormally high excitation current, so that the vibrator contacts are burned before the vibrator becomes properly started in the circuit. There are numerous ways of overcoming this difficulty, involving patented circuitry, relays, and the like; but in most cases, the practical consideration is to design the transformer

- with sufficient inductance in the primary circuit, which is then combined with a buffer or timing capacitor utilized in the primary circuit to accomplish good reliable starting. In the event that a primary buffer is used, it is also common practice to utilize an additional capacitance in the secondary circuit to provide the proper timing for the vibrator. The primary buffer is selected to meet the starting requirements. The second function is to time the vibrator circuit.
3. Self-rectifying vibrators can be utilized to accomplish high efficiencies, but caution must be taken not to exceed the manufacturer's voltage rating on the portion of the vibrator in the secondary circuit. It is customary to use such vibrators for circuits with outputs not exceeding 3 to 400 volts at nominal input voltage. Use on higher output voltage circuits is normally avoided because of the inherent danger of voltage arc-over or breakdown in the vibrator as a result of the high voltage being handled.
  4. Vibrator power supply circuits will give the best performance and longest and most reliable life when utilized with a capacitor-input filter. The use of the choke-input filter or the use of a vibrator circuit as an inverter creates additional difficulties at the vibrator contacts. Normally, additional circuit precautions must be taken if the designer feels that such use must be made of the vibrator.
  5. The input impedance to a vibrator power supply should be kept as low as possible to obtain maximum performance. It should be recognized, however, that in the case of high-voltage input circuit, it is necessary to maintain a minimum impedance in the primary circuit to accomplish satisfactory starting. The use of r-f chokes in the input leads is often necessary, and in these cases, the choke should be sufficiently bypassed to prevent excessive contact erosion on the vibrator contacts. Recommended practice is to keep the value of such chokes below 30 microhenries.
  6. The designer should keep in mind that the battery charge operating a vibrator power supply has many times, percentage-wise, the variation in voltage from that normally encountered on a-c operation. In other words, a 6.3-volt battery can vary from a low of 4.5 volts to as high as 8 volts when under charge. Thus, the designer must consider the extreme fluctuation of input voltage encountered by the vibrator power supply and take adequate precaution to ascertain that his circuit will operate satisfactorily at the low battery voltage, and that he has enough safety factor in his design to assure safe, reliable operation at the extremely high input voltage encountered.
  7. High ambient temperatures adversely affect the life and reliability of a vibrator. Therefore, proper ventilation should be provided, so that the vibrator will operate in an ambient temperature not to exceed 85 C.
  8. When the vibrator power supply is to be mounted on the same chassis as the receiver or associated equipment, precaution should be taken to locate the vibrator, transformer, and rectifier as far away as possible from the r-f section of the associated equipment. The power supply should be well shielded and securely grounded. It is recommended that r-f grounds be made at only one point on the chassis, in order to prevent ground-current radiation. Leads carrying the r-f current should be as short as possible and run close to the chassis. Critical leads should be shielded, and r-f chokes should be located very close to the vibrator portion of the power supply to reduce effectively the interference that the vibrator power supply could create in the set or associated equipment.
- Vibrator Selection. The selection of the proper vibrator to be used in the designing of a circuit requires a comparison of the various mechanisms that are available and a consideration of the end results expected. The choice between an interrupter and a self-rectifying vibrator should be made according to the types of service desired, the operating efficiency necessary, and the limitations of the various vibrator mechanisms themselves. It is strongly recommended that the designer use a standard, available mechanism as a basis for his circuit design, for in this manner, he will obtain the most reliable performance in life. The use of special vibrators or vibrators especially adjusted for a particular use should be avoided; such vibrators are unavailable from many sources, and the special adjustment required may result in less than optimum performance, which could have been obtained had the design been modified to permit the use of a standard mechanism. In addition, the following items should be considered in the selection of a vibrator for any particular circuit.
1. Vibrators are normally rated at 4, 6, 12, 24, and 32 volts. Circuits should be designed to use these standard voltage vibrators and, while it is possible to use one vibrator for two consecutive input voltage ratings by use of appropriate dropping resistors, the designer should not attempt to utilize one vibrator for more than two such voltages. In all cases where equipment has been designed to use the vibrator on three input voltage variations, considerable difficulties have been encountered in the proper drive of the of the vibrator, and the results in general were unsatisfactory.

2. The current rating of a vibrator is in general reduced adversely as the voltage rating is increased. Many inexperienced designers expect a vibrator to handle as much current at 24-volts input as it could at 4-volts input, but the manufacturers' rating sheets show that this is not true. In judging the input current handling ability of a vibrator, one should obtain the manufacturer's ratings and see that these are not exceeded in making the design.
3. The standard frequency rating of vibrators is  $115 \pm 7$  cps. The designer should use a vibrator of this frequency wherever possible. While special frequencies have been used, such frequency variations generally result in a deteriorated performance and nonavailability of more than one source for such vibrators.
4. The vibrators will give satisfactory performance in a range of temperature from  $-55$  C to  $+85$  C. Any use of vibrators beyond this temperature range will result in deterioration of performance and, therefore, it is desirable that the equipment be designed in such a way as not to exceed this temperature range.
5. Vibrators have been, and can be, supplied in a variety of base arrangements and types and sizes of enclosures. However, in general, the industry has standardized particular basing arrangements, enclosures, and sizes for particular uses. The designer should keep these standardized vibrators in mind, since this will facilitate procurement.
6. It should be recognized that the output voltage of any circuit is a function of the time efficiency of the vibrator and the turns ratio of the transformer, together with the efficiency of the rectification means. The vibrators of various manufacturers will vary in time efficiency, dependent upon the particular mechanism furnished by a manufacturer. The designer should take extreme care in seeing that representative vibrators from all potential sources are checked in his circuit to be sure that the circuit will function properly. The precaution is repeated that the attempt to alter a particular vibrator design to overcome a circuit deficiency generally results in impaired and unsatisfactory performance.

## SYNCHROS AND SERVOS

No rotating machines were returned to the Bell Laboratories during the period of their Navy contract /2/ and, therefore, no reports on this type of equipment will be found in the terminal report on the Components Reliability Program. The preliminary

report on the reliability program conducted by Vitro /1/ showed that 4 motors out of a total population of 180 in radar SR-6 had failed. Report No. 25 /24/, however, states that 18,150 replacements had been made for a total population of 5,500 self-synchronous motors. No breakdown or explanation of this 3 to 1 replacement figure is given.

Data on the failure rates for synchros and servos, therefore, is meager. It must be presumed that failures occur, and the following notes /38/ must be considered as advisory only.

Synchros. There are two basic types, torque synchros and control synchros. Both contain a stator core mounted in a frame and a rotor core mounted on a shaft. One or more windings is on each core. The current for the rotors must be conducted to the synchro lead terminals through slip rings and brushes. The input or transmitter synchro and the output or receiver synchro are connected together electrically and to the power source in such a way that when the input shaft is turned, torque is developed in the receiver, and the output shaft turns to the proper position. The interconnection may or may not contain tube or magnetic amplifiers.

The torque produced by the receiver synchro approaches zero as the error approaches zero and the accuracy of follow-up is dependent upon the amount of friction present and the rate at which the torque approaches zero. Friction is a limiting factor, and for extreme accuracy, it must be kept as low as possible.

Control Synchros. Systems using the synchro only as a control element overcome some of the problems that occur with torque synchros. Here, the synchro geared to the input shaft is called a control transmitter and the synchro geared to the output shaft is called a control transformer. When an error exists, the control transformer develops a voltage that is proportional to the sine of the error angle. The phase of this voltage reverses when the error angle changes from positive to negative. This voltage is amplified and supplied to a servo motor geared to the output shaft and driven in such a manner that the error is reduced to zero. As the error angle approaches zero, the voltage from the control transformer approaches zero.

Control synchros can be much smaller and lighter than torque synchros, and systems using two synchros geared to the input shaft, one turning much faster than the other, and two similar synchros geared to the output shaft, are capable of extremely good accuracy.

Synchro Troubles. Corrosion is the principle cause of trouble, with temperature being an additional problem. If moisture can enter the windings, it may cause insulation breakdown between the windings or between winding and frame. The air gap between rotor and stator is relatively small, and failure will result if corrosion settles on the outside of the rotor or the inner surface of the stator. Corrosion on the slip rings or brushes will prevent

satisfactory operation. Improper lubrication of the ball bearings is another cause for failure.

Manufacturers are continually improving these rotating instruments toward the achievement of units that will tolerate greater vibration and high temperatures.

Synchro control transmitters and control transformers, resolvers, induction potentiometers, and differentials must be selected properly. The following items will aid the manufacturers in interpreting the requirements of the servomechanism designer.

1. Type of synchro.
2. Excitation voltage and frequency.
3. Physical size limitations.
4. Required input and output impedance.
5. Maximum power input in watts.
6. Angular function required and accuracy tolerance.
7. Shaft configuration.
8. Environmental conditions involved.
9. Face mounting requirements.
10. Type of connection to be used.
11. Transformation ratio between the voltages on the several windings.
12. Vibration to be encountered.

The reliability of a synchro lies somewhere between that of a static transformer and an electronic chassis. The ball bearings and slip rings form hazards to reliability that the transformer does not possess. With proper design and use, synchros will not compromise the reliability of an automatic control system.

Servomotors. During operation, a servomotor is continually reversing, changing speed, starting, and stopping. It is being driven by an amplifier, which operates from the error signal, and the motor is continually being driven to bring the error to zero. In many cases, the inertia of the control motor itself is the largest part of the system inertia and therefore controls the system response. Since system designers are continually striving for more rapid response, the torque-to-inertia ratio in the motor is of extreme importance.

If the control motor does not respond in a linear manner to the amplifier, stability troubles are encountered.

The a-c servo control motor differs from the standard industrial type motor in several important respects. It is basically a two-phase motor. One

phase, called the fixed phase, is excited continuously from one a-c service at a fixed voltage. The other phase, called the control phase, is excited from a service 90° out-of-phase with the fixed phase service. The control-phase voltage is continually adjusted up and down and reversed in phase by the control amplifier. The control motor seldom, if ever, operates as a true polyphase motor, since it will operate in this manner only with one specific control-phase voltage. Under normal conditions, the fixed phase usually draws about the same amount of power, regardless of the control-phase voltage. This power is approximately the power required at locked rotor. The control motor is wound with a fixed number of poles. The number of poles and the supply frequency determine the synchronous speed of the motor, which is the speed at which the magnetic field in the motor will revolve when the fixed and controlled phases are fully excited. Normal industrial induction motors run within 3 to 5 percent of synchronous speed. The servomotor is seldom, if ever, used at any speed above 50 percent of synchronous speed.

In the servo control motor, it is necessary to have considerable torque available when the motor control-phase voltage is suddenly reversed, with the motor operating at speeds between zero and one-half of synchronous speed. This torque, of course, is used to reverse the direction of the motor rapidly. The requirement for torque under this condition of operation leads to a very high motor resistance in comparison to industrial motor practice. Since all of these special requirements of the servo control motor tend to reduce the efficiency below that of the industrial induction motor, some steps must be taken to recover some of the losses. The stator is made considerably larger than a comparable industrial induction unit. These servo control motors operate quite satisfactorily in small sizes, that is, in outputs up to about 10 mechanical watts. In larger sizes, the efficiency problem makes this type of design impracticable.

The servo control motor should produce no torque when the control voltage is zero. As the control voltage is raised from zero, the control motor should produce a smooth, uniform torque independent of rotor position, increasing as the control voltage is increased. These requirements make it necessary in the design of the motor to use extreme care with regard to flux distribution, rotor homogeneity, slot combinations, skew, and air gap. Since the requirements are for relatively high rotor resistance and low inertia, most small motors use cast aluminum squirrel cage construction. The control of the casting of these squirrel cage rotors is one of the important problems in the manufacture of servo control motors.

Servo Motors Failures. Service troubles are usually due to one of the following causes.

1. Corrosion in the air gap between rotor and stator.
2. Breakdown of electrical insulation.
3. Bearing failure.

It is usually necessary to use an extremely small air gap between rotor and stator to obtain acceptable performance. The result of using a small air gap is that minute particles of foreign matter or traces of corrosion on either stator or rotor surface can cause a failure. The magnetic laminations of some of these motors are, therefore, made of high-nickel iron in an effort to reduce corrosion. The surfaces of the rotor and stator should be coated with corrosion-preventive material.

Fortunately, progress in insulation techniques has kept up with the rate at which system designers demand smaller and smaller servos and their resultant crowding of windings. Therefore, it is possible to obtain small servomotors with far better insulation breakdown resistance than is found in small conventional motors. The servomotor, however, still is a power device — unlike the synchro — and must dissipate considerable heat. The user should provide adequate areas for conducting and dissipating this heat, using convection wherever possible. Excessive temperature is the primary cause of insulation failure in these instruments, with humidity a close second.

The servomotor is very dependent upon its bearings. Since it is invariably used with a gear train that involves friction, and since friction is the chief factor limiting the accuracy of the system, bearing care is important. It is usually necessary to select the lubrication on the basis of friction-torque developed, which usually does not result in the longest possible life. Great care must be exercised in the mounting of the bearings in the servomotor to ensure that no additional friction is created in the

mounting. New insulating materials and bearing lubricants are making it possible to produce a servomotor that will operate at temperatures of 100 C and higher.

The servomotor has a relatively high degree of reliability if properly applied and used. Both synchros and servomotors are instruments, and should be treated with the care and consideration that fine instruments require. They are delicately adjusted at the factory and normally it is impossible to make any internal adjustments in the field. In case of a failure, the instrument should be replaced and the defective unit returned to the factory for repair.

Some of the important things to be specified in connection with servomotors are as follows.

1. Voltage and frequency.
2. Physical size.
3. Stalled torque required.
4. Maximum speed unloaded.
5. Maximum inertia permissible.
6. Maximum control watts available.
7. Mounting face requirement.
8. Shaft or pinion required.
9. Environmental conditions.

## REFERENCES

1. Electronic Equipment Reliability Report, Technical Report No. 45 (Summary), Vitro Corporation of America, Contract NObsr 52215, 31 March 1953. See Report No. 25 for statistical data on this Navy survey.
2. Final Report, 15 July 1953, Bell Telephone Laboratories, Component Reliability Program, Contract No. NObsr-52480.
3. Taylor, Dennis, "The Reliability of Nucleonics Instruments," paper presented at Industrial Electronics Convention, 9 July 1954, Oxford, England and to be published in the Journal of the British Institution of Radio Engineers.
4. Carhart, R. R., "Survey of Current Status of the Electronic Reliability Program," Report No. RM-1131, The Rand Corp., Santa Monica, Calif., August 14, 1953.
5. Carhart, R. R., "Fundamental Concepts of Reliability in Guided Missiles," Convair Lecture Series, Summer 1953.
6. The bulk of this material was prepared by A. L. Wilson and Norman B. Ritchey, Sylvania Electric Products Co., Kew Gardens, N. Y.
7. Acheson, Marcus A., "Electron-Tube Life and Reliability -- Variation of Life Performance with Usage Conditions," National Conference on Airborne Electronics, May 1954.
8. Investigation of Electron Tube Reliability in Military Applications, Aeronautical Radio, Inc., BuShips Contract No. NObsr-52372, January 4, 1954.

## REFERENCES (Cont)

9. Techniques for Application of Electron Tubes in Military Equipment, United States Air Force Air Research and Development Command, Wright Air Development Center, Wright-Patterson Air Force Base.
10. Acheson, Marcus, and Eleanor M. McElwee, "Concerning the Reliability of Electron Tubes," Proceedings of the IRE, Vol. 40, No. 10, October 1952.
11. Acheson, Marcus A., "Electron Tube Contact Potential Phenomena," Engineering Memorandum, 6th issue, August 30, 1954, Sylvania Electric Products, Inc.
12. Jervis, E. R., "Reliability of Electron Tubes in Military Applications," Proceedings of the IRE, Vol. 42, No. 6, June 1954.
13. "Electron Tube Grid Currents," Application Engineers of the Advisory Group on Electron Tubes, Tele-Tech, November 1954.
14. Radiotron Designers Handbook, 4th Edition, p. 113.
15. Miller, J. M., "Dependence of the Input Impedance of a Three-Electrode Vacuum Tube upon the Load in the Plate Circuit," Bureau of Standards Bulletin No. 351, 1919.
16. Freeman, R. L., "Use of Feedback to Compensate for Vacuum Tube Input Capacitance Variations with Grid Bias," Proceedings of the IRE, Vol. 26, November 1938, p. 1360.
17. Merrington, M., and C. M. Thompson, "Tables of the Percentage Points of the Inverted Beta (F) Distribution," Biometrika, Vol. 33, 1933, p. 73.
18. Langstroth, Frank, Agenda for the Fifth Meeting, RETMA, Electronics Application Committee (Reliability), Washington, D. C., November 30, 1954.
19. Good, L. H., "When Are Transistors Practical?" Engineers Digest (RCA), January-February 1954.
20. Rockett, Frank, "Fixed Resistors Show Stability Improvements," Electronics, September 1954, p. 132.
21. Marsten, Jesse, Radio Engineering Handbook, 4th Edition, 1950, p. 98.
22. Sloanker, R. D., and B. L. Stone, "Component Parts Requirements and Evaluation for Large-Scale Computer Applications," Proceedings, 1954 Electronic Components Symposium. Copies are obtainable from RETMA, 500 5th Ave., New York City.
23. Data supplied by Leon Podolsky, Sprague Electric Co., North Adams, Mass.
24. Report No. 25, 1 November 1951, Vitro Corporation of America, Electronic Equipment Reliability Program.
25. Cramer, C. H., and P. H. Wells, "Submerged Telegraph Repeaters, Current Developments and Applications," Proceedings of the Radio Club of America, Vol. 29, No. 3, 1952.
26. Bulletin No. 45, Aircraft Radiation Laboratory, Wright Air Development Center, 17 February 1954.
27. Data supplied by Byron B. Minnium, Erie Resistor Company, Erie, Pa.
28. Paine, B. B., "Silver Migration in Electronic Equipment," Electronic Applications Reliability Review, No. 3, RETMA, 1954.
29. Kohman, G. T., "Silver Migration in Dielectrics," Conference on Electrical Insulation, National Academy of Sciences, National Research Council, Pocono Manor, Pa., October 18, 19, and 20, 1954.
30. Data supplied by R. M. Purinton, Consulting Engineer, Boston, Mass.
31. Walter, G. E., "Progress in Size and Performance of Electronic Transformers by a Better Definition of Life Requirements," Proceedings, Electronic Components Symposium, May 1952. See also Hamilton, R. L., and G. E. Walter, "Determination of Transformer Life," Proceedings, Electronic Components Symposium, May 1954.
32. Smith, J. Roy, "Inductors and Their Application," Reliability Design Handbook, Naval Electronics Laboratory, San Diego, Calif.

## REFERENCES (Cont)

33. Sturley, K. R., Radio Receiver Design, John Wiley and Sons, Inc., Second Edition, 1953. See also Radiotron Designers Handbook, Radio Corporation of America, Fourth Edition, Harrison, N. J.
34. Medhurst, R. G., "H-F Resistance and Self-Capacitance of Single Layer Solenoids," Wireless Engineer, February-March 1947.
35. Data supplied by Francis J. Fratar, F. W. Sickles Division, General Instrument Corp.
36. Sumner, Milton R., "Misapplication of Relays in Complex Airborne Electronics Equipment," Proceedings, Electronic Components Symposium, May 1954.
37. Data supplied by Albert Tollefsen, P. R. Mallory and Co.
38. Cripps, Ray H., American Electronic Manufacturing Co., October 7, 1954.

## BIBLIOGRAPHY

- Acheson, Marcus A., "Electron Tube Contact Potential Phenomena," Engineering Memorandum, 6th issue, August 30, 1954, Sylvania Electric Products, Inc., New York City.
- Acheson, Marcus A., "Electron Tube Life and Reliability -- Variation of Life Performance with Usage Conditions," National Conference on Airborne Electronics, May 1954. Copies obtainable from Sylvania Electric Products, Inc., 1760 Broadway, New York City.
- Acheson, Marcus A., and Eleanor M. McElwee, "Concerning the Reliability of Electron Tubes," Proceedings of the IRE, Vol. 40, No. 10, October 1952.
- Dumont Oscillographer, July 1954.
- "Electron Tube Grid Currents," Application Engineers of the Advisory Group on Electron Tubes, Tele-Tech, November 1954.
- Ferris, W. R., "Input Resistance of Vacuum Tubes as UHF Amplifiers," Proceedings of the IRE, Vol. 24, January 1936.
- Freeman, R. L., "Use of Feedback to Compensate for Vacuum Tube Input Capacitance Variations with Grid Bias," Proceedings of the IRE, Vol. 26, November 1938.
- Investigation of Electron Tube Reliability in Military Applications, General Report No. 1, January 4, 1954, ARINC, Bureau of Ships Contract NObsr 52372, Index 110231.
- Jervis, E. R., "Reliability of Electron Tubes in Military Applications," Proceedings of the IRE, Vol. 42, No. 6, June 1954.
- Merrington, M., and C. M. Thompson, "Tables of the Percentage Points of the Inverted Beta (F) Distribution," Biometrika, Vol. 33, 1933.
- Miller, J. M., "Dependence of the Input Impedance of a Three-Electrode Vacuum Tube upon the Load in the Plate Circuit," Bureau of Standards Bulletin No. 351, 1919.
- Minutes, Symposium on the Application of Tubes in Guided Missiles for Maximum Reliability, sponsored by the Panel on Electron Tubes and published under Contract DA 36-039 SC 5597 (no date given).
- North, D. O., "Analysis of the Effects of Space Charge on Grid Impedance," Proceedings of the IRE, Vol. 24, January 1936.
- Proceedings of Symposium, Progress in Quality Electronic Components, Washington, D. C., May 1952. Copies obtainable from RETMA, 500 Fifth Ave., New York City.
- Proceedings of the Symposium on Electro-Magnetic Relays, Oklahoma Institute of Technology, Oklahoma A & M, June 29 and 30, 1953.

**BIBLIOGRAPHY (Cont)**

Radiotron Designers Handbook, 3rd edition, Radio Corporation of America, Harrison, N. J., Chapter 7, p. 46.

See also 4th edition.

"Series Heater and Filament Strings in Military Equipment," Application Engineers of the Advisory Group on Electron Tubes, Tele-Tech, January 1955.

Stein, S. J., and J. Riseman, "Evaporated Metal Film Resistors," Proceedings, Electronic Components Symposium, May 1954. Copies obtainable from RETMA, 500 Fifth Ave., New York City.

Strutt, M. J. O., and A. Van Der Ziel, "The Causes for the Increase of Admittance of Modern High Frequency Amplifier Tubes on Short Waves," Proceedings of the IRE, Vol. 26, August 1938.

Sylvania Engineering News Letters No. 97 and 98.

Technical Data for Armed Services Preferred List of Electron Tubes, Armed Services Electron Tube Committee.

Terman, F. E., Radio Engineering, 2nd edition, McGraw-Hill Book Co., New York City.



# CONTENTS

## chapter nine

### **interference**

**Interference Reduction at the Transmitter**

**Interference Prevention Techniques**

**Shielding**

**Bypassing and Filtering**

**Output Filters**

**Power Line Filters**

**Low vs. High-Impedance Filters**

**Harmonic Suppression Filters**

**Circuit Grounding**

**Interference Reduction at the Receiver**

**Limiters**

**Wave Traps**

**Phase Cancellers**

**Audio Filters**

**Common Impedance Troubles**

**Jamming**

# chapter 9

## INTERFERENCE

Electronic equipment today performs so many related duties that it is becoming customary to group the equipments together in "systems." The advantages of such grouping are the greater ease of intercommunication among equipments and among operating personnel, compactness of housing, and simplification of facilities. But grouping in limited areas of apparatus performing many different functions brings up the problem of mutual, and other, interference.

At a radar site, for example, there may be an early warning radar, a heightfinder, a search radar, IFF, communications services such as c-w, phone, teletype, ground-to-plane phone, point-to-point phone, facsimile – all competing for space in the radio spectrum and all pouring their energy into the ether.

The equipment designer has a twofold problem: he must design equipment so that it works properly and effectively with other directly related equipment and at the same time, he must so design his equipment that it does not interfere with, or be interfered with by, other equipment with which it has no direct relation.

The problem is acute, since radio communication is possible only because modern receivers are exceedingly sensitive and, for this reason, are prone to pick up interference from any source of radio energy.

Transmitter Interference. At the transmitter, interference is produced in several ways, aside from the primary purpose of the equipment. Harmonics of the fundamental frequency can escape from the transmitter to cause interference many miles away. Parasitic oscillations may cause interference on virtually any frequency. Mutual interference between antennas may cause trouble.

Receiver Interference. At the receiver, interference may arise from several causes. These are (1) man-made noise from motors, diathermy apparatus, fluorescent lamps, arcing contacts, leaky insulators, television receivers, and so on, and (2) radiation from radio transmitters to which the receiver may or may not be tuned.

Although much can be done at the receiver to minimize unwanted interference, the proper place to kill such interference is at the source. The several techniques for reducing interference, both at the source and at the receiver, are discussed below.

### INTERFERENCE REDUCTION AT THE TRANSMITTER

Modern radio transmitters are highly complex. They usually consist of low-power low-frequency stages, buffers and frequency multipliers, drivers, modulators, and final amplifiers. None of the energy from any of the low-frequency stages should be permitted to escape from the transmitter cabinet. No stage should be permitted to oscillate or tend to oscillate and produce parasitics thereby. The final stage is usually driven hard to achieve the maximum power output and is prone to produce harmonics. Even though the energy in these higher frequency emissions may be low, it is potent.

An improperly designed or operated transmitter may create interference locally and at distant points on frequencies both lower and higher than the basic fundamental frequency.

Interference Prevention Techniques. Although it is possible to de-bug an existing transmitter that is creating interference, it is much easier to do this job in the design stage. Some useful design principles that should be observed are indicated below:

The techniques are of three sorts.

1. Shielding of the transmitter to prevent direct radiation.
2. Bypassing and filtering of all power supply leads, key leads, and so on, so that energy from the cabinet is not conducted out of the cabinet except via the antenna leads.
3. Filtering the r-f output so that harmonics and other frequencies cannot escape via the transmission line to be radiated by the line or the antenna.

**Shielding.** A well-shielded transmitter cabinet is the first step. If direct radiation from the transmitter exists, it will not do much good to try to plug up the power lead holes in the chassis or filter the r-f output lines.

The value of shielding increases with the thickness of the material, the square root of its conductivity, the square root of its permeability, and the square root of the frequency. Therefore, choose the shield to attenuate the interference at the lowest desired frequency. If the shield must be self-supporting, it will probably be thick enough for all except very low frequencies.

Table 9-1. Shield thickness to produce 33 db attenuation at 1 Mc

Metal	Relative conductivity	Minimum thickness in mils
Aluminum	0.61	13
Brass	0.25	20
Copper	1.00	10
Magnesium	0.37	16.5
Silver	1.05	10
Steel	0.035 to 0.6	25 to 55
Tin	0.15	26
Zinc	0.29	18.5

A solid aluminum wall produces an attenuation, due to absorption, of 2.6 db per mil at 1 Mc; thus, a shield 22 mils thick will produce a loss of about 57 db, and since the loss increases as the square root of the frequency, the attenuation is 570 db at 100 Mc. Additional losses occur because of reflection.

A layer of flexible metal braid produces about 45 db at 1 Mc, but a second layer provides only 25 db more loss, except at high frequencies, where it produces about the same loss as the first layer.

Proper shielding implies that the transmitter box or cabinet is electrically tight. The ideal is a solid, highly conductive box with no holes in it. This is rather impractical, since power must get into and out of the box; it must have handles, doors, lids, ventilating ducts, and so on. Furthermore, the individual

pieces of cabinet metal must be joined. The joints or seams must not present a high impedance to the flow of radiation through them. They must be electrically excellent connections, free of paint, rust, scales, and the like, so that the inside of the cabinet looks like one continuous sheet of high-conductance material. One method of joining two pieces of shielding is shown in Figure 9-1, and there are other methods for performing the same useful function.

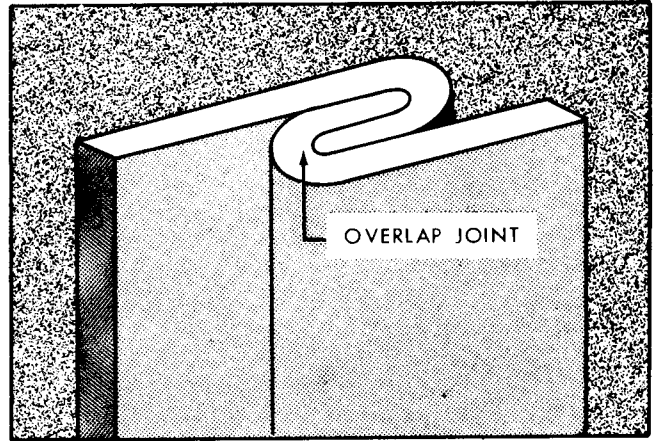

Figure 9-1 Cabinet panel seams

Radiation will escape from a transmitter cabinet through any hole. Therefore, air vents and other orifices should be covered on the inside of the cabinet with a fine metal screen, preferably of high-conductivity copper. This screen must be bolted to the cabinet and must be electrically well connected to the cabinet. (See Figure 9-2.)

Punching a hole in the cabinet or chassis and running in power wires is very bad practice unless proper precautions are taken. Not only has a hole been made through which energy will escape, but electrical conductors have been placed through the hole, conductors that will act as transmission lines to carry the energy to a location where it is unwanted.

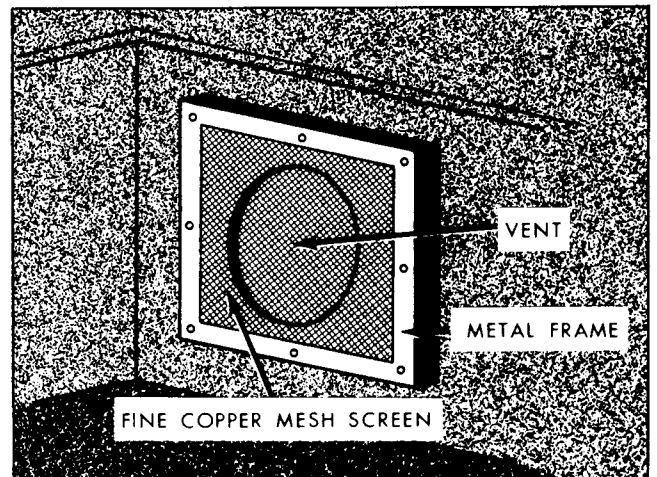

Figure 9-2. Air vent in cabinet wall

Power connections should be run in shielded cable or conduit and should terminate in male-female connectors, so that the shielding has good electrical connection to the metal cabinet. If, then, the proper wires are suitably bypassed and filtered on the inside of the cabinet, it will be much easier for the unwanted energy to stay inside the cabinet than to get out and travel along the power wires.

Modern practice is to shield fully meters that are inserted in the front panel of a transmitter. Doors and lids, or other necessary openings for service, must be arranged so that when shut, there is good electrical connection of the entire periphery of the movable part with the cabinet proper. Metal mesh or fingers of metal are useful for this purpose. The mating surfaces must be clean, and equal pressure around the periphery is desirable.

**Bypassing and Filtering.** If the shielding of an existing transmitter is so good that direct radiation from the chassis or cabinet has been eliminated, it is possible that the transmitter will not cause sufficient trouble to force the operator to go to further measures. But if the transmitter is in the design stage, the additional steps are highly desirable.

One of these steps is to bypass and filter all power supply leads. By using capacitors that are small in size and have the shortest possible leads, low-impedance paths are provided for r-f currents to flow to ground (the inside of the metal cabinet) in preference to flowing along the supply leads outside the cabinet. The shortest possible length of supply lead should be exposed inside the cabinet between the bypass capacitor and the external lead. If, in addition to the capacitor, a choke is inserted in this short inside length of supply lead, r-f currents find not only an easy path to flow away from the leads, but a high-impedance path along the lead.

The purpose of such filtering is to attenuate r-f currents and to keep it out of any external wiring. Feed-through capacitors are vastly superior to ordinary mica or paper bypass capacitors for this purpose.

Use of shielded hookup wire for all power leads, key or microphone leads with adequate grounding of the braid at several points, will aid in keeping r-f energy out of such connections. Naturally, any wires going from one piece of equipment to another must be shielded and filtered. Details of r-f filters are given below. Some of the ways in which interference is created between electronic equipments are cited below.

**Some Case Histories.** A control cable going from the receiving location to the transmitter site had one unused wire in it. At the transmitter end, the ungrounded wire acted as a pickup antenna, and at the receiving site, the ungrounded wire acted as a transmitting antenna.

In a ground station, h-f and v-h-f equipment

were fairly close together. The h-f transmitter was designed to work directly into the antenna, and not through the means of a shielded or balanced transmission line. The antenna lead brought the transmitted signals directly into the receiving location and caused much trouble at 12 Mc, the approximate intermediate frequency of the v-h-f receiver. In this case, transmitter design should have enabled it to work into a low-impedance line with the antenna at any desired distance away from the v-h-f receiver. It was found that considerable 12-Mc voltage existed along the control and power wires that connected the receiver and transmitter locations.

The modulator of a search radar was shielded but not adequately grounded; surplus pulse cable was just wound up and clamped near other wiring; the a-c lead from modulator to an external blower was shielded, but the ground connections were long enough to pick up trouble; the coaxial antenna cable for loran passed through the interference field and brought noise directly into the receiving location.

A single-wire interphone system caused much interference, which was easily cleaned up by installing a two-wire system. Any one-wire-plus-ground communication or power or control circuit is virtually sure to cause trouble.

A television receiver created much trouble, which was found to be due to the fact that the chassis was about 1/2 wavelength in physical length at the disturbing frequency and acted as a good antenna.

**Output Filters.** All transmitter amplifiers have harmonics. The job is to keep these harmonic currents out of the transmission line and antenna, so that they cannot radiate. A balanced line is of no help, because of capacitive coupling to the tank of the transmitter. Such coupling will produce current flowing down the balanced line at the harmonic frequency, the line acting more or less like a single-wire feeder. A filter in this line will help, provided it is of the type shown in Figure 9-3. A Faraday screen between tank and pickup coil is additional insurance.

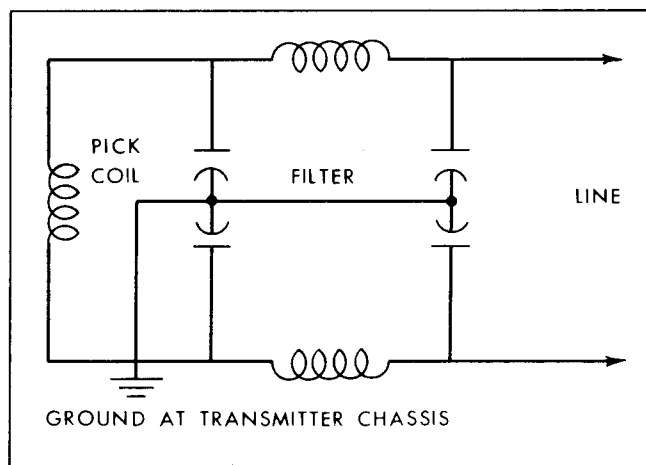

Figure 9-3. Capacitive harmonic coupling to a two-wire transmission line

It is easier to filter an unbalanced transmission line, such as a coaxial. The filter will be simpler than that required for the balanced line. And the coaxial line itself will be shielded.

Now, if undesirable r-f currents can be prevented from getting onto the coaxial shield and can be kept inside the cabinet, and if the filter is properly protected from r-f fields, it is likely that all interference trouble from the transmitter will be prevented. See Figure 9-4 for the proper way to install coaxial line to keep r-f current from reaching the outside world via the line shield. The common type of construction shown in (a) offers little shielding to the harmonic currents flowing on the chassis and link. Part of this undesirable current will be transmitted on the

outside of the coaxial line to other parts of the equipment. However, if the equipment is constructed as shown in (b), with a top shield and bottom plate, this situation is avoided. Punching a hole through a shield and passing coaxial line through it (c) is perhaps the poorest method of all. This method only tends to frustrate any shielding that is put in. /1/

In general, line filters are of two types. In one type the filter acts like a quarter-wave line and is designed so that it has high impedance to a certain harmonic of the transmitter frequency. In the other case, it is a low-pass filter, which attenuates all frequencies higher than that of the transmitter. This type is more desirable. It may be permanently installed at the transmitter output. The harmonic type must be changed if, for example, the fourth harmonic of the transmitter is to be employed instead of the second.

**Mutual Interference.** Wherever possible, transmitting and receiving sites should be well separated. Such location makes it possible to use more frequencies without getting into mutual interference problems, enables the operators at the receivers to copy weaker desired signals, and reduces man-made noise at the receiving site. At a transmitter "park," mutual interference is a prime consideration in layout.

**Antenna Separation.** At a transmitter site, antennas should be separated from each other by appropriate distances to avoid mutual interference. Considerable research in this area has been accomplished, but as yet precise information on appropriate spacings is not available. Generally, if possible, a half wavelength separation at the operating frequency should be used. If the transmitters have about equal power but operate on appreciably different frequencies, separations of a 1/4 wavelength are satisfactory. If the antennas are fed with open-wire lines, minimum coupling between lines will result if the separation between lines is about 8 times the separation between wires in a given line. Single wire with ground return is never recommended if freedom from mutual interference is desired. Such interference can result from cross modulation of one transmitter by the other.

While modern receivers are relatively free from spurious responses ("birdies"), it is possible for a strong transmitted signal to correspond to one of the weak spurious receiver responses, with the result that the operator may be confused or even have trouble in copying a desired signal on or near this frequency. For this and other reasons, it is highly desirable to separate transmitters and receivers.

Considerable information on avoiding or correcting mutual interference may be found in TM 11-486, Electrical Communications Systems Engineering.

**General Rules to Follow at the Transmitter.** To prevent a transmitter from interfering with services other than those directly associated with the transmitter, the design engineer should:

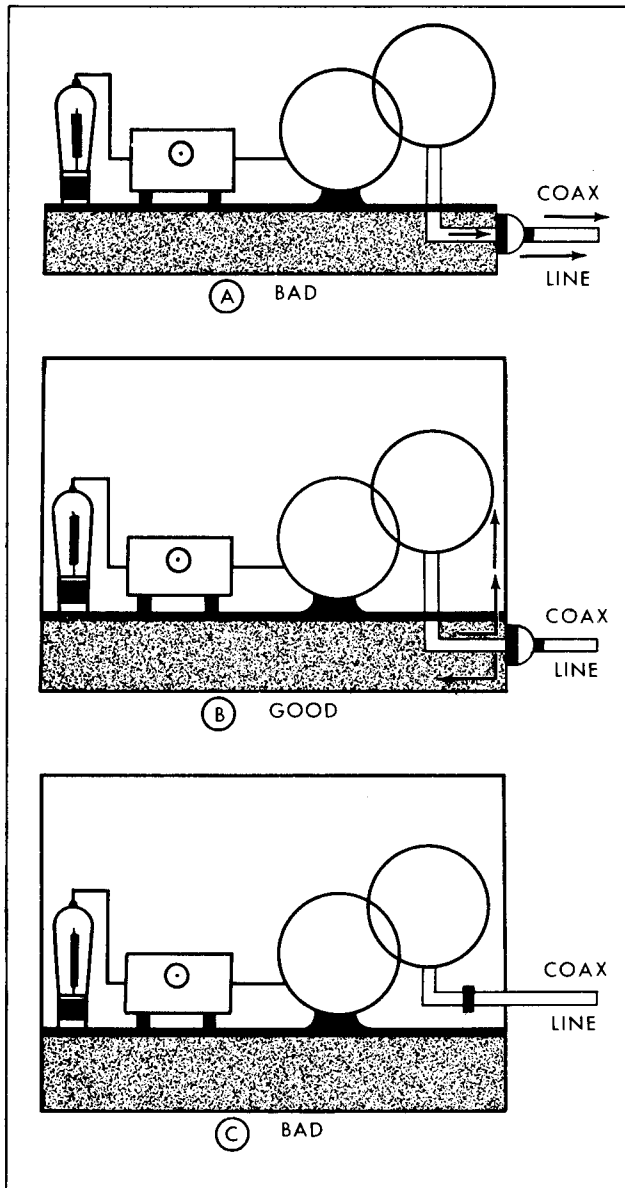

Figure 9-4. Right and wrong ways of connecting coax to an r-f amplifier

1. Shield the transmitter and all its parts.
2. Use shielded hookup wire for all power and low-frequency leads inside the chassis and cabinet. Ground the braid of this wire in several places.
3. Bypass all power and low-frequency wires with small capacitors, using leads as short as possible.
4. Filter the power and low-frequency leads with chokes.
5. Run interconnecting wires between equipments in shielded cable and use adequate grounding.
6. Use low-pass or harmonic filters in the r-f output between transmitter and transmission line.
7. Use balanced transmission line or, better, coaxial line, between transmitter and antenna or between antenna and receiver.
8. Avoid bundling together a bunch of transmitting and receiving power leads.
9. Guard against parasitics in the transmitter.
10. Employ proper spacing between transmitting and receiving antennas. Orientation of these antennas with respect to each other will help in holding down the amplitude of the interference.

**Power-Line Filters.** /2/ Merely bypassing power leads to ground will help keep unwanted r-f interference from getting out of a transmitter cabinet. A real job of filtering, using both chokes and capacitors, is much better practice. Such filters will

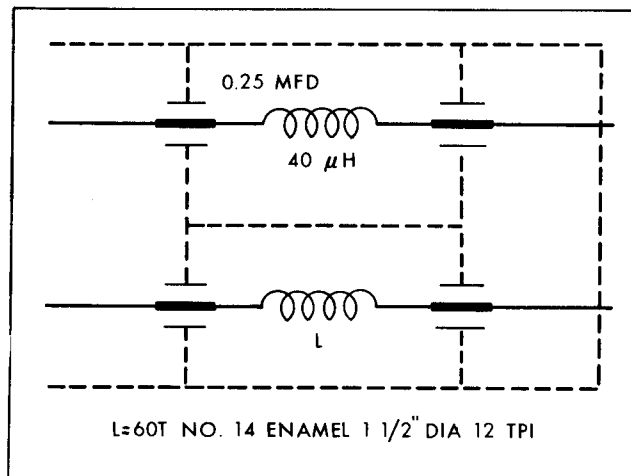

Figure 9-5. Filter to keep radio frequencies out of power wires

make low-frequency and power leads "cold," so that they do not conduct r-f energy from the transmitter to other locations.

The filter shown in Figure 9-5 can be employed for this purpose, or it can be used at the receiver to keep unwanted radio currents out of the receiver chassis. It will provide about 40 db attenuation over the long-wave and medium-wave broadcast bands and over the TV bands, and will be good up to and beyond 150 Mc. The feed-through type of capacitors do not become resonant until about 100 Mc. Beyond that, they act as series-resonant circuits to ground and provide high attenuation. The loss to r-f currents falls off slowly after the capacitors go resonant.

In general, it is better to use low-pass or high-pass filters instead of band-pass filters, unless the ratio of upper to lower cutoff frequency is less than 2 to 1.

**Low- vs. High-Impedance Filters.** If the source of interference has a low impedance to the interfering currents, a low-impedance filter network will have higher currents through its input than if a high-impedance filter were used.

If the source has a high impedance to the interfering currents, a high-impedance network will permit a greater voltage across the circuit than is permitted by a low-impedance network.

A capacitor-input filter provides more attenuation, in general, than an inductance-input circuit, but if it is desired to reduce the unwanted currents before the application of the network, the inductance-input filter should be used. The inductance decreases currents to all frequencies, including those that are causing the trouble. These types of filters are commonly used in power supplies.

Noninductive capacitors should be employed in all cases of r-f filtering. For shunting currents to ground, employ the single-terminal type with case grounded. (See Figure 9-6.) Always use minimum possible lead length to keep inductive reactance low and resonant frequency high. (See Figure 9-7.)

Coils for r-f filters need not have high Q. If the Q is of the order of 5 to 10, the coil will be good enough. The distributed capacitance must be kept low. This may be accomplished by connecting several coils in series so that the various capacitances of the individual coils are in series. Since this also lessens the inductance of the coil, because it eliminates some of the mutual inductance between the turns of different coils, a compromise must be found. Multilayer coils should be avoided because of their high distributed capacitance.

If the wire size is twice that required by the power current to be carried, a safety factor high enough will be provided.

#### Harmonic Suppression Filters. Details of

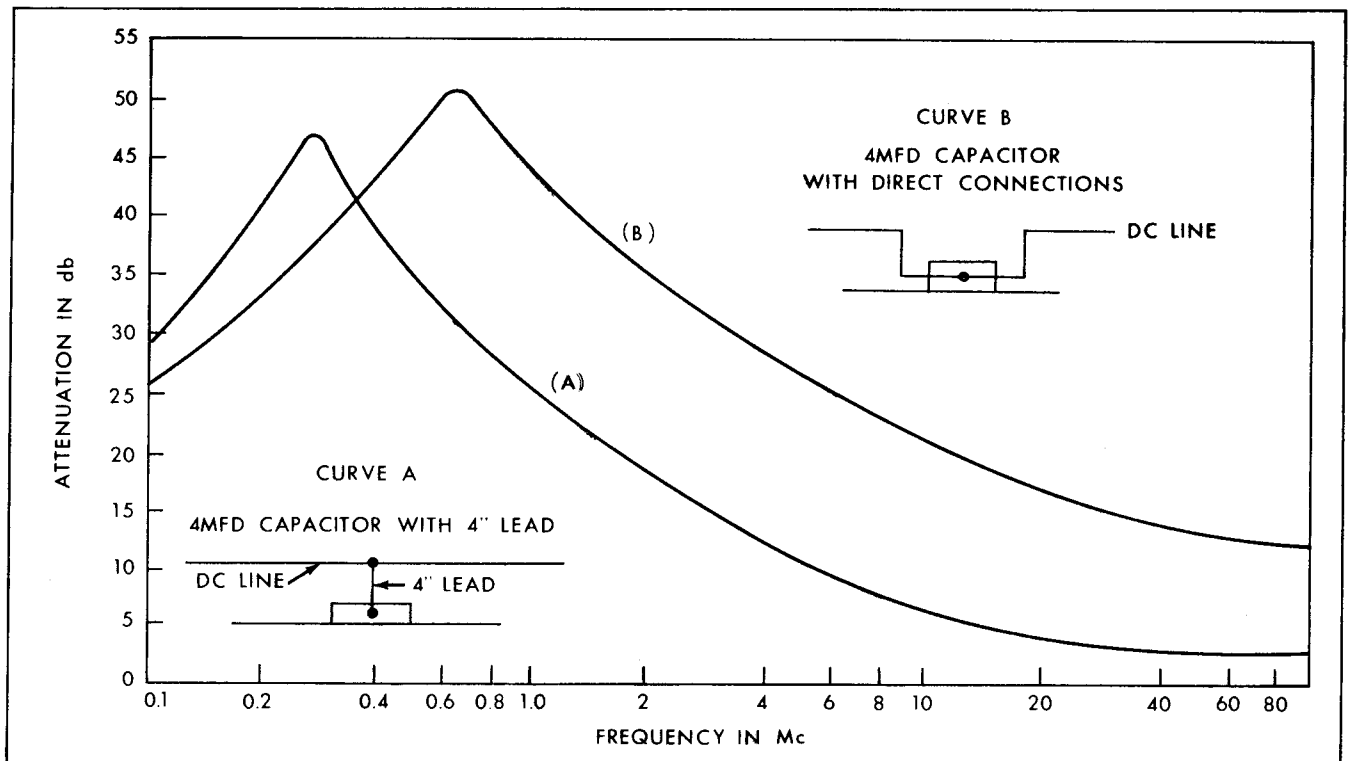

Figure 9-6. Difference in capacitor attenuation with different arrangement of leads

amateur radio field. These networks are inserted between the transmitter and the antenna transmission line, or between the line and the antenna. Of course, from the standpoint of keeping unwanted harmonics at home, the best place is at the transmitter end of the transmission line.

In designing such filters, use a cutoff frequency 1.5 times the fundamental frequency. General requirements for such filters are:

1. In the passband, the filter should act merely like a section of the transmission line, that is, have the same impedance as the line and, therefore, cause little or no loss in power.
2. The attenuation should be 60 db or more between 1.10 above and 4 times the cutoff frequency, and not less than 30 db at between 4 and 10 times the cutoff frequency.
3. In the passband, the VSWR should be less than 1.10 over the whole band; no greater loss than 1/2 db should be caused.

If still greater attenuation is required, it is better to use more than one complete filter, instead of trying to build a single filter satisfying the requirement.

At frequencies above 70 or 80 Mc, use sections of transmission lines as filters.

Proper placement of power-line filters is important. It is futile to install them in such a way that the output leads are exposed to r-f fields, or so that the output and input leads are coupled to each other. The energy in the input leads can easily infect the output connections so that the benefit of the filter is partially lost. Shielding the output wires is highly desirable.

**Circuit Grounding.** No part of a metal chassis of a transmitter should be allowed to carry r-f current. Otherwise, the chassis is likely to be a splendid radiator of energy. The way to prevent this kind of trouble is to make all grounds to a single point on the chassis. For example, a tank circuit with several points grounded should never have actual ground connections distributed over the metal chassis. If this latter practice is carried out, then some part of the tank current is sure to flow through the chassis, causing coupling to other parts of the transmitter. This will present feedback troubles, which are difficult to locate. Chassis and shields should not be used for electrical conductors. All parts of the chassis should be electrically "cold" to all radio frequencies.

A radar, of course, is a prolific source of radio interference. Much can be done to hold down such troubles if careful design and common sense are utilized.

In a particular case, a radar modulator of the line type produced a sharp peak of about 140 microvolts of noise at 2 Mc along the power line, and

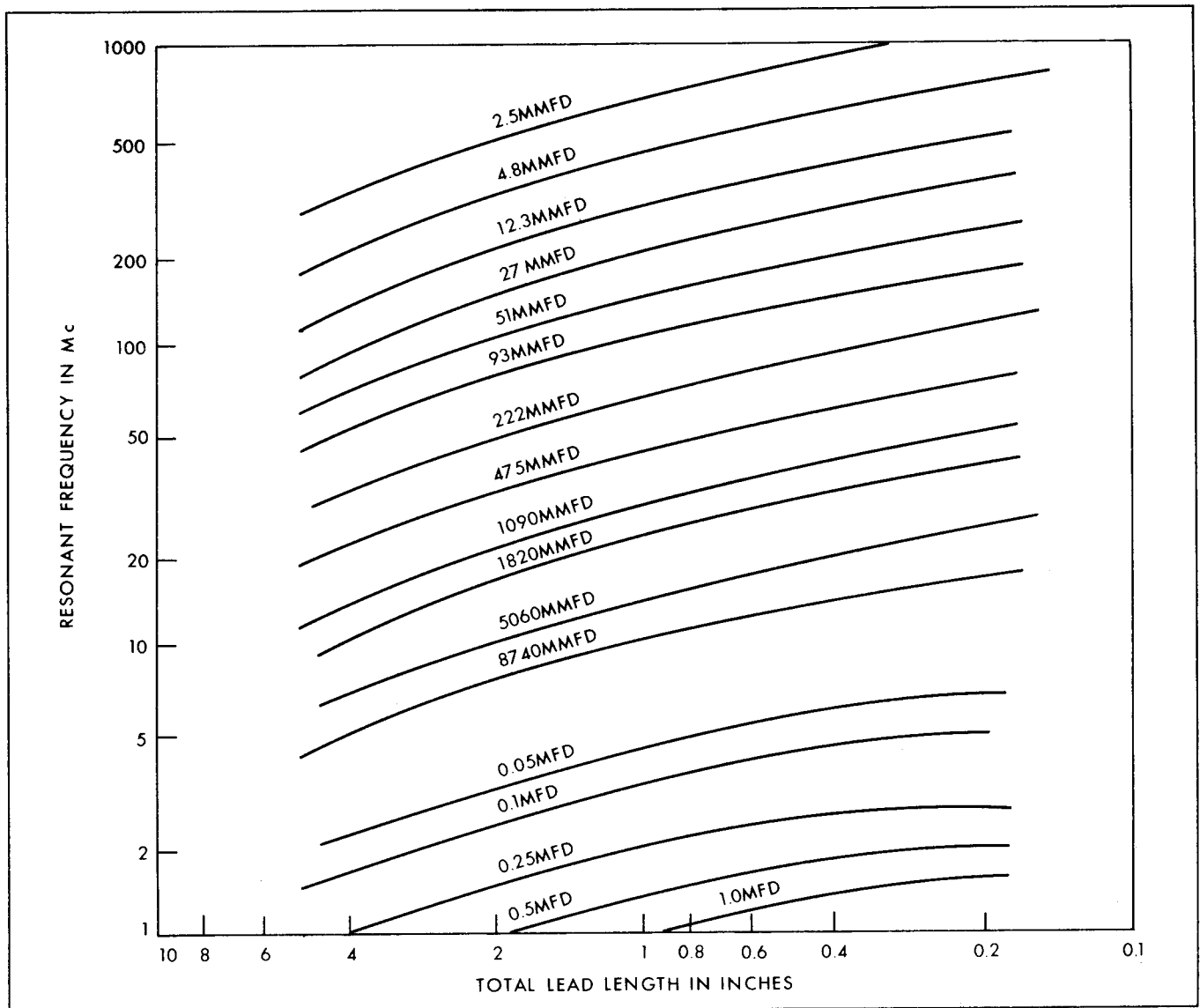

Figure 9-7. Series resonance of small capacitors as a function of lead length

this noise spread over the band from 1 to 3 Mc. A single copper shield was placed between the the primary and secondary of the windings of the filament and plate circuit power transformers. Primary leads were kept as far as possible from the thyatron and at right angles to other wiring. The primary leads were shielded with copper tubing from the transformers to the point where they left the modulator case. The tubing was grounded. A partition separated the rectifier and the thyatron. All this reduced the interference along the power line to about 50 microvolts in the range from 0.2 to 20 Mc.

It must be remembered that  $1/4$  or  $1/2$  wavelength is not very long at the high frequencies, and that ground wires of this general magnitude, or sections of shield between ground points of this length, may become quite efficient radiators.

#### INTERFERENCE REDUCTION AT THE RECEIVER

Although the best place to reduce inter-

ference of any kind is at the source, much can be done at the receiver location. Modern communications receivers are of very great sensitivity, often being required to deliver a recognizable and readable signal on about one microvolt, and must often do this in the presence of fields of hundreds of volts per meter of off frequency interference. The receiver must be well shielded, so that direct radiation from nearby transmitters cannot get into any of the r-f, i-f, or other circuits to cause interference. The power supply leads, including the a-c line cord, should be filtered at the receiver, and at times, it helps to run these wires in grounded shield.

If the noise at the receiver location can be reduced by a factor of 3 db, the effect is the same in the useful output of the receiver as if the transmitter power had been doubled – the signal-to-noise has been improved by 3 db. Doubling the power of a transmitter can be very costly in size, weight, money, and com-



plexity, whereas small, low-powered components may lower the noise at the receiver.

**R-F Interference.** Even if the receiver is adequately shielded and has filtered power leads, it still may have to exist in the vicinity of powerful local transmitters. Then the operator must use local and external means to reduce the interference. The techniques that may be employed are wave traps inserted at the antenna binding post, limiters, blanking circuits, phase-cancelling circuits, or audio filters.

Limiters and blanking circuits are useful when the interference is of large amplitude pulses with pulse length short compared to their period. Wave traps are useful if the interference consists of a narrow band of frequencies. Phase cancellers are useful only if the character and path of entry are known precisely. Audio filters are useful only when the interference consists of a small number of fixed audio-frequency components.

**Limiters.** Using a separate limiter is better practice than employing the limiting properties of an existing tube whose real job is something else. Limiters are most effective when the selectivity after the limiter is greater than before the limiter. A simple series limiter is shown in Figure 9-8.

Actually, they are useful only in receivers with some r-f gain that rectify at a level of at least

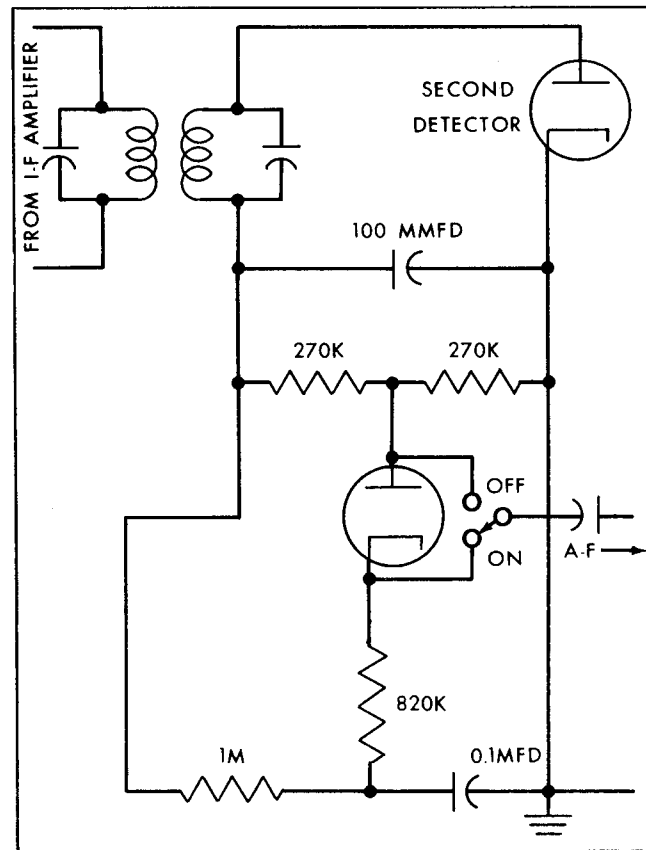

Figure 9-8. Series limiter

0.1 volt. They are good for reducing interference having a low pulse repetition rate. The ideal situation is low prf and wide bandwidth. With v-h-f receivers having natural wide bandwidth, a series limiter will provide 30 to 35 db of attenuation to unwanted pulses.

Limiters provide considerable protection against natural static and ignition noise. Parallel limiters do not seem to be as useful, in general, as the series type.

**Wave Traps.** An antiresonant wave trap inserted in the receiver antenna lead is a very old trick and is still very useful. If the desired and undesired frequencies are close to each other, use low L/C ratio and high Q; if the two frequencies are far apart, Q has little effect on the rejection ability of the network and a Q of 10 is sufficient.

A series-resonant circuit across the receiver antenna post and the ground post should have high L/C ratio and high Q. Typical constants for the amateur bands are given in Table 9-2.

Table 9-2. Wave trap data

Freq. in Mc	Capacitance in f	Inductance in H	Coil Design 1 in. by 1 in.	
			Turns	Wire size
3.5	140	16	32	22
7	100	6	19	22
14	50	3.5	14	18
21	35	2.2	12	18
28	25	1.5	9	18

Wave traps or filters tuned to radar frequencies and located at the receiver input will reduce the incoming voltage and prevent shock excitation of the input circuit. Quarter-wave stubs connected between antenna post and the receiver case and made of

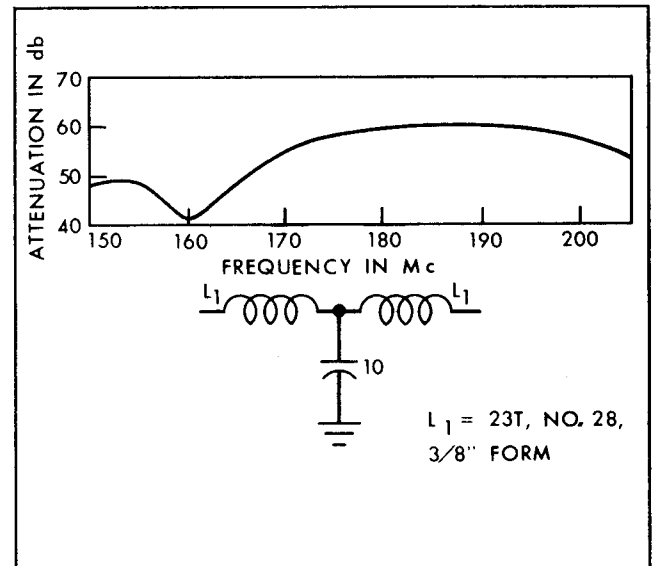

Figure 9-9. Low-pass filter useful for receiver protection

twisted-pair or parallel wires with the far end open are good to v-h-f and u-h-f below about 600 Mc. Wave traps made from coaxial line have sharp cutoffs, and for this reason are not so useful.

A simple low-pass filter shown in Figure 9-9 has a high attenuation over the band of 150 to 200 Mc and beyond.

The value of feed-through capacitors is shown in Figure 9-10.

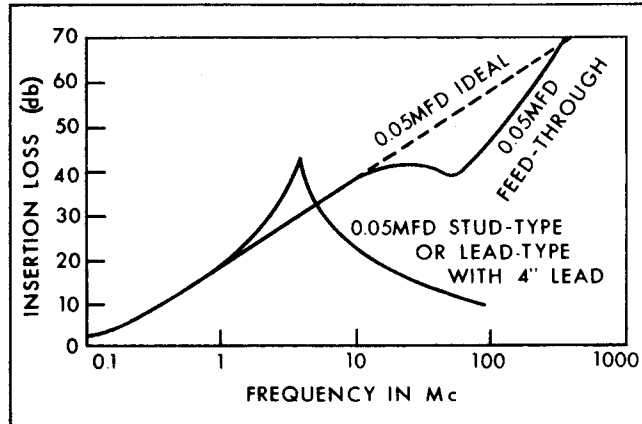

Figure 9-10. Curves of insertion loss as a function of frequency comparing feed-through and lead-type capacitors with ideal capacitors

In several types of aircraft, the following types of wave traps are being used successfully to reduce interference from IFF and similar systems operating at frequencies about and above 50 Mc.

1. An r-f choke, designed to resonate with its distributed capacitance, is installed in the antenna circuit of the communication receiver. Such a coil consists of three series windings of 15 to 30 turns each, depending on the interfering frequency, wound on a bakelite form roughly 3/8 inch in diameter and 4 inches long.
2. A quarter-wave open-circuited stub is connected between the antenna post and ground of the communication receiver. This stub consists of No. 18 solid copper, insulated, push-back type wires, about 1/4 wave long and twisted about 9/10 of their length, the remainder serving as leads. The stub should be cut back experimentally until maximum interference reduction is obtained. This point is critical, and the wires should not be cut back more than 1/8 inch at a time to make sure that this point is not missed. A short length of coaxial cable may be used instead of the twisted wires. Its length must be adjusted by trial and error in the same way as

3. A three-section parallel-resonant series wave trap constructed from coaxial cable, similar to the r-f choke, may be inserted between the antenna relay and the receiver antenna post. Each section is approximately one-quarter wave long and short-circuited. The exact dimensions are determined by trial and error.

Other techniques being used to reduce interference under similar conditions are listed below.

1. All pulse cable shields are grounded at the connectors. (It was found that in some cases only one of the shields was grounded because of greater ease of assembly, a practice which resulted in the loss of much of the shielding effectiveness.)
2. A suitable filter is installed in series with the a-c lead from modulator to external blowers.
3. The modulator and receiver transmitter is placed as far as possible from other radio equipment, especially the liaison and radio compass receivers. These receivers should be in a separate compartment, if possible.
4. The pulse and high voltage cables should not be bundled with, run parallel to, or placed less than one foot from, other radio and aircraft wiring. At least an 18-inch separation should be maintained for cable lengths over 20 feet.
5. All wiring associated with the radar set must be well isolated from other aircraft wiring.
6. Modulator and receiver-transmitter units are located so that pulse cable lengths are held to a minimum.
7. Since the pulse cables are prefabricated in fixed lengths, extra cable is sometimes coiled to take up surplus. In case this is necessary, the coil should be placed in isolated compartments and adequately spaced from other wiring.
8. All radar components should be properly bonded to the aircraft or other "ground" structure. The modulator and receiver-transmitter units should have at least two such bonds of shortest practicable length.
9. The a-c lead from modulator to external blowers should be filtered with a

portion of the lead between modulator and the filter shielded and grounded with short leads.

10. In case interference due to penetration or leakage of the pulse cable shield is encountered, the interference may be reduced by grounding the shield at intervals of approximately 5 feet.

Phase Cancellers. These consist of some sort of pickup for the interfering noise, an attenuator, and a phase shifter. The output is fed to the receiver along with antenna currents which also contain unwanted signals. They are only useful over a narrow band and are complex.

Audio Filters. These devices will, in general, only decrease the annoyance to the operator of the unwanted noise; they will not eliminate it. For example, a filter tuned to the pulse repetition frequency of a radar will reduce the strength of the undesired noise and its harmonics but will not add appreciably to the intelligibility of the desired signal. Filters reduce operator fatigue.

Receiver Design. As in transmitters, careful ground techniques within the receiver chassis will pay off. The chassis should not be allowed to carry any oscillator current. The field of the oscillator coil should not be coupled to the chassis or shield. The coil should be long compared to its diameter or should be wound on a high permeability form to confine its field. The coil should be spaced at least two coil diameters from the shield, which should be of high-conductivity copper. It must be remembered that coils tuned by varying the position of an iron core have much larger fields at the high-frequency end of the tunable band.

At a minimum frequency of 80 Mc, a minimum thickness of copper of about 0.003 inch will produce an attenuation of about 80 db.

If the receiver circuits can fully use the available bandwidth (as in F-M), a wide band will permit greater discrimination against noise. Another advantage of the wider band is the fact that pulses entering the circuit are not distorted and lengthened. That is, a pulse entering a circuit whose bandwidth is narrower than the frequency spectrum of the pulse will cause the receiving circuits (often the intermediate frequency) to ring at the resonant frequency of the circuit. But a wide band also permits more noise to enter the system. These requirements are contradictory. The designer must compromise between the desire to permit more interference to enter the system and to rely on effective limiting to suppress it later, or to limit the interference coming into the system by using narrow bandwidth but then to be without means of limiting it at some later point.

It is surprising how much interference a good receiver can tolerate if it is adequately shielded, if it has a good limiter, and if it has an avc of short-time constant, so that it recovers quickly after a burst of locally-generated noise hits it—a local keyed transmitter for example.

It is also surprising how much trouble small defects in design can produce. For example, an unshielded oscillator coil is near the front panel of the receiver. In adjusting any of the knobs, the operator can throw an incoming signal completely out of the passband by changing the distance between the panel and coil. If this oscillator coil is near any shield that may get warm from nearby tubes, then drift is absolutely certain, no matter how well-regulated may be the power supply to the oscillator tube. The coil inductance is made up, in part, by the metal in the shield; that is, the coil inductance is not the same inside a shield as it is out in free space. Variations in the position of the shield, therefore, change the inductance of the coil and change the tuning of the oscillator.

Man-Made Noise. Man-made noise is unpredictable, sporadic, and virtually uncontrollable except when it is generated by equipment over which radio personnel have some cognizance. The ways in which it can be reduced at the source are documented and well-known. The Broad approach is stressed here, and the reader is referred to the literature for greater detail:

Some of the rules that are useful in keeping man-made noise to a minimum are:

1. Get rid of the noise at the source, if possible.
2. Avoid fluorescent lamps where a sensitive receiver must be used, especially if operation in the 50-Mc region is necessary. Such noise is very difficult to clean up.
3. Do not permit an antenna relay to be in the same cabinet as the receiver input. Or, if necessary, install the relay in a shielded compartment with all leads well bypassed and filtered.
4. Do not bundle together receiver and transmitter leads.
5. Be careful to avoid unwanted coupled circuits; that is, do not tolerate any unwanted common impedance between circuits that are not to be coupled.
6. Use a-c motors instead of d-c motors wherever possible. If fractional horsepower d-c motors must be employed, put them in shielding boxes and filter the

leads. Dynamotors are prolific sources of noise, because they have two commutators.

7. Use vacuum-tube switching circuits, instead of relays or vibrators, wherever possible.
8. Keep the number of leads entering a receiver to the lowest possible number.
9. It is not sufficient merely to reduce the duration of an arc — it must be prevented. Use capacitance and resistance in series across the gap; the capacitance holds down the voltage so that arcs don't start, and the resistance both damps out any arcs that may occur and provides a means for dissipating the magnetic energy that exists before the contact is opened.

**Interference Aspects.** The direct cause of man-made and radio noise is coupling of some sort between the source and the receiver, or by radiation. The coupling means are magnetic and electrostatic. Any wire carrying a current has a magnetic field, and any other wire in that field will have currents induced in it from the source field. It is worth noting that the direction of the current flowing in the coupled circuit can be reversed by changing the orientation of the coupled wires, and by that means, interference can be eliminated or reduced in many cases. Trouble from capacitively coupled circuits is not so easily balanced out, since the current flowing in the coupled circuit depends only upon the voltage in the source. Changing the orientation will only change the magnitude of the induced current, not its direction.

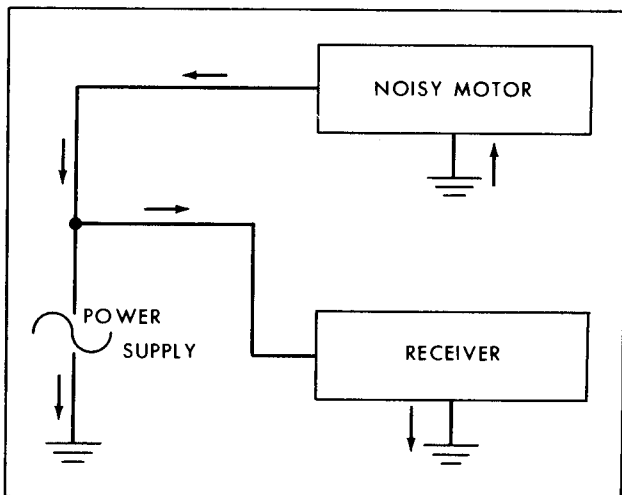

Figure 9-11. One way for noise to get into a radio receiver

**Common-Impedance Troubles.** Figure 9-11 shows in a very elementary way how noise from motors or other sources can be brought directly into a receiver via the power leads. Here, a motor and a

receiver get power from the same circuit. The noise currents from the motor have two ways to complete the circuit to ground: one through the power supply system, and one through the receiver power leads that bring them in proximity to the receiver input circuit. Proper filtering of both motor and receiver power leads not only provides a short and direct path to ground of the motor noise, but prevents it from entering its own power supply leads.

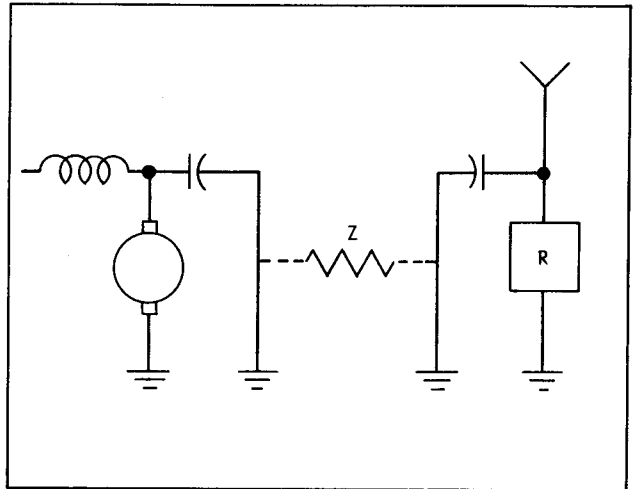

Figure 9-12. Unwanted motor noise coupled to circuit

In Figure 9-12 the noise-carrying wires are capacitively coupled to the receiving system wires.

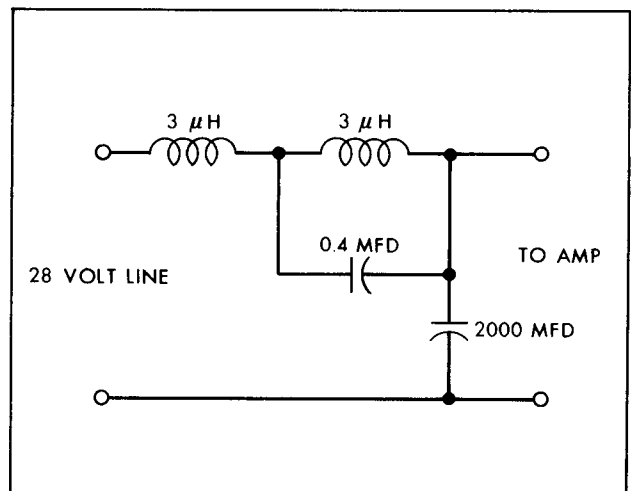

Figure 9-13. Filter to remove 4,000-cps interference

**Line Filters.** To be most useful in attenuating man-made noise, line filters must be placed very close to the exit of power wires from the equipment, or inside the equipment case or cabinet. Even a few inches of wire between the source and the filter will radiate. If possible, keep the noise from getting out of the machine; get rid of it at the source.

Filter leads or filter coils must not be permitted to be in any interference field. For example, the output leads of the filter should not be coupled to the input leads where the noise is strong. These statements are applicable to r-f filters as well as to low-frequency noise filters.

It is worth noting that shunt capacitance will produce the same attenuation as series inductance, with less weight and volume, but that capacitance across a source will actually increase source currents of interfering frequency (because it lowers the impedance these currents flow through), whereas series inductance lowers currents at all frequencies.

Figures 9-13 and 9-14 illustrate a simple filter employed to eliminate 4,000-cps interference in an interphone amplifier. This trouble was caused by a 28-volt motor by conduction via the d-c bus, where 4.4 volts at this frequency was measured.

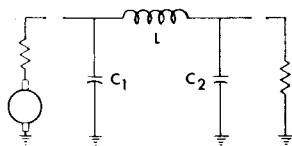

**Remarks**

Determine wire size for coil from table on right.

Voltage rating of capacitors should be about twice generator or load voltage. (50 volts recommended for 28 volt systems.)

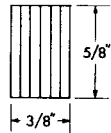
Freq. range	L	C <sub>1</sub>	C <sub>2</sub>
150 Kc to 20 Mc	12 turns single cotton enameled magnet wire on 3/4" diameter form, close wound; laminated iron core 3/8" x 5/8" with sufficient length to accommodate winding; laminations 0.025" thick 	4 mfd Single terminal (grounded metal case)	1.3 mfd Single terminal (grounded metal case)
20 Mc to 100 Mc	10 turns enameled magnet wire on 1/2" diameter form, space wound (equivalent to diameter of conductor)	0.5 mfd Single terminal (grounded metal case)	0.01 mfd mica (leads as short as possible)
100 Mc to 150 Mc	8 turns enameled magnet wire on 1/4" diameter form, space wound (equivalent to diameter of conductor)	500 mmfd mica (leads as short as possible)	500 mmfd mica (leads as short as possible)

Max current in amps	Wire size	Diameter in mils	k*	
			EN & SSC	DSC & SCC
1.5	22	25.3	37	34
2	21	28.5	32.9	29.8
4	18	40.3	23.7	22.0
6	16	50.8	18.9	17.9
10	14	64.1	15	14.2
15	12	80.8	12	11.5
25	10	102	9.6	9.3
40	8	128	7.6	7.4
70	6	162	----	----
100	4	204	----	----
175	2	258	----	----

\* Approximate only, since thickness of insulation depends on type of insulation and manufacturer.

EN - Enamel  
SSC - Single silk covered  
DSC - Double silk covered  
SCC - Single cotton covered

Figure 9-14. Design data for 4,000-cps filter

**Jamming.** The main purpose of antijamming circuits is to prevent receiver saturation. Manual adjustments are impractical because it is quite impossible to follow the rapid fluctuations in jamming with a manual control. A signal of 80 db above normal receiver interference level, coupled with 50 db of clutter, would appear as a 30 db signal if the receiver gain were properly reduced. With normal gain, how-

ever, the signal would be invisible, since the clutter would saturate the receiving system. This is particularly true in the case of an intensity-modulated indicator, such as a plan position indicator. When the beam intensity is increased too much, the focus is destroyed, and the spot is said to "bloom." The plan position indicators have a small dynamic range, around 10 to 20 db, and therefore require a limiter stage in the preceding video amplifier. This prevents strong signals from causing blooming.

Four types of circuits are useful against jamming and clutter:

1. Sensitivity time control circuit. These circuits control the receiver gain as a function of time after the initial radar pulse. The gain is reduced when the radar pulse is first sent out and then gradually increased to normal value as deter-

without strong directional characteristics, such as sea or land surfaces.

2. Automatic gain control circuits. An instantaneous automatic gain control rapidly decreases the gain of an intermediate-frequency stage when the stage output increases beyond a value determined by the circuit constants. This action prevents stage saturation. It is advisable to protect the last two or three i-f stages with this type of control. The circuit usually operates with a time constant of about 20 microseconds.
3. Short-time-constant networks. The coupling between the second detector and first video stage is provided with a very short-time-constant network. The network serves to remove or attenuate, by differentiator action, the d-c and low-frequency components encountered in continuous-wave or low-frequency modulated jamming. The time constant is usually made equal to the radar pulse width.
4. Bias-control circuits. These circuits automatically supply to the second detector a bias that prevents the high-frequency components of interference-modulated jamming from saturating the video section. The circuit can be designed with a short-time constant. For this reason, a delay network is also necessary,

so that individual signals will not be reduced in amplitude, that is, cut off too soon.

5. MTI. These circuits are used to eliminate clutter. Fast moving targets are presented to the scope, but signals caused by clutter are cancelled out.

The short-time-constant and the bias-control circuits are most effective when used in conjunction with the instantaneous automatic gain control circuit. At frequencies below the points where the short-time-constant circuit cuts off, the fast-time-constant and instantaneous gain control are an effective combination against jamming by modulated or unmodulated continuous waves. Modulated jamming and most types of clutter, especially that caused by clouds, are best controlled by a combination of bias and instantaneous automatic gain control.

High-power pulsed radar systems operating near each other can readily cause mutual interference, even though there is considerable separation of their operating frequencies. The radar receiver does not offer sufficient attenuation for extremely strong off-frequency signals. Interference may also be caused by pickup of the large video signals radiated from a nearby modulator. Blanking circuits have offered the most effective solution to this type of interference. A receiver gating pulse is developed and applied to one or more intermediate-frequency grids and synchronized with the transmitted pulse of the interfering set.

## REFERENCES

1. Grammer, G., "Eliminating TVI With Low-Pass Filters," QST, February 1950.
2. Much of the information in the remainder of this chapter is based on material that appears in Design Techniques for Interference-Free Operation of Airborne Electronic Equipment, Frederick Research Corporation, for U. S. Air Force, Wright Air Development Center, p. 19, 1952.

## BIBLIOGRAPHY

"Analysis of the Response of an Ideal Band-Pass Element to Periodic Quasi-Impulsive and Pulse Repetitive Phenomena," Electronic Interference Analyzer, Rome Air Development Center, 29 February 1952.

"Cabinet Shielding Techniques," Electronic Interference Analyzer, 4 March 1952.

Davis, Arthur S., "Design and Operation of Audio Filters for Suppression of Periodic Pulse Noise," Electronic Interference Analyzer, 28 April 1952.

"Design Data for Spherical Seat Couplings," Electronic Interference Analyzer, 1 January 1952. Reprinted from article dated 3 February 1948, Electronics Division, BuShips, Navy Department.

Design Techniques for Interference-Free Operation of Airborne Electronic Equipment, Frederick Research Corporation, for U. S. Air Force, Wright Air Development Center, 1952.

Electrical Communication Systems Engineering, TM 11-486, 25 April 1945.

Elimination of Radio Interference in Aircraft, and the Prevention and Elimination of Certain Electrical Interferences in Missiles, NavAer 16-5Q517, Report No. R53A0511, General Electric Co.

Gait, John James, "Interference in Communication Receivers from Radar D-C Pulses," RAE Technical Note No. Rad. 342, Royal Aircraft Establishment, Farnsworth, England, December 1945; also in Electronic Interference Analyzer, Rome Air Development Center, 14 March 1952.

"Notes on Design of Radar Systems Which Do Not Cause Radio Interference," AAF Air Technical Service Command, Engineering Division Technical Note, Serial No. TN-TSERR-1, Issue No. 2, 25 April 1945.

"Radio Interference Bibliography," Electronic Interference Analyzer, 1 March and 1 April 1952. Extensive bibliographies from worldwide sources.

Radio Interference Suppression Techniques, Coles Signal Laboratories, November 1950.

# CONTENTS

chapter ten

## **automatic production techniques**

Automatic Production of Electronic Equipment

Military Need for Automatic Production

Different Philosophies

Project Tinkertoy

Auto-Sembly

Requirements for the Automatic Production of  
Military Electronic Equipment



# chapter 10

## AUTOMATIC PRODUCTION TECHNIQUES

As previously discussed in the chapter on Mechanical and Environmental Factors, a designer's knowledge of electronics must be supplemented with an understanding of the mechanical and environmental factors that may affect his equipment if this equipment is to have the optimum reliability. Although these considerations fall in different engineering fields, the nature of electronic design is such that they still are his responsibility.

One other consideration falling in this same category shall now be discussed, namely, manufacturing. The problems that arise here are primarily the concern of the production engineer but the reliability of the equipment may be enhanced or degraded by the requirements specified by the designer.

This chapter attempts to acquaint the designer with various manufacturing techniques and to show how they may affect his present and future work.

### AUTOMATIC PRODUCTION OF ELECTRONIC EQUIPMENT

Referred to by some as one of the main-springs for a second industrial revolution, the complete mechanizing of electronic equipment production is an idea that captures the interest and fires the imagination of the designer, the production engineer, and even the ordinary layman. The idea itself is by no means new but, until a few years ago, its practical application could well be called a futuristic dream.

Like so many other instances of progress made in the past, this advancement had to wait for technological improvements in allied fields before becoming a reality. The automatic production of components came first, with the manufacture of resistors probably being foremost in this field. Then followed the development of such techniques as miniaturization, subminiaturization, and unitization. Finally, with the

acceptance of the various techniques used for printed wiring, the stage was set for the automatic production of electronic equipment.

The British Sargrove machine, patented in 1943, was probably the first large-scale attempt in this field. Starting with a plastic plate, the machine used a spraying-milling technique to produce the wiring, resistors, capacitors, and inductors on a flat surface. /1/ Automatic testing and hand insertion of some of the larger components followed.

Intended to supply the vast Chinese and Indian markets, the machine had a production potential of 500,000 sets a year but, because of the large capital investment required, could not operate economically on runs of less than 100,000. Besieged with such problems as excessive rejects for its manufactured components, and confronted with the loss of its foreign market, the machine became a victim of international politics and financial shortcomings, and was ultimately dismantled and stored. Nevertheless, Sargrove's early work pioneered the way, and the lessons learned from it have been of inestimable value in subsequent development. Today, further work is being carried on in England at the Telecommunications Radio Establishment in Malvern.

In the United States, the earliest semimechanized techniques were probably those applied to the ordnance proximity fuze in 1945. /2/ This consisted of depositing conductive paint through a silk screen stencil onto a ceramic plate. Commercial applications of this development soon followed, with the advancement of hearing aid production being most noteworthy. Today, automatic production programs are being sponsored by the three branches of the military, while organizations such as General Electric, Bell Laboratories, Stanford Research Institute, and Sylvania have initiated studies, either independently or in conjunction with various government agencies.

Why Automatic Production? A certain amount of salesmanship is necessary to prove that a new design or technique is sound and offers practical advantages. Discussions must be held, articles written – in short, the idea must be publicized. Once accepted, however, this new idea requires more than publicity to transform it into a physical reality. To understand why, one need only look at the very competitive electronics industry.

Few serious attempts have been made toward a completely mechanized electronic equipment assembly process. /3/ The high initial investment evolving from the complexity of the machinery required has been the prime deterrent. The specialized nature of the production process has also been a difficult situation to resolve, since experience has shown that many standard manufacturing processes employing only a moderate degree of automaticity are often incapable of economically accommodating relatively small design changes. Electronics today often requires many extensive design changes over relatively small periods of time to keep pace with rapidly expanding military and industrial applications. With these factors in mind, it is understandable that electronic equipment assembly methods have generally not progressed much further than those of hand operations employing convenient jigs, fixtures, and hand tools.

And so, if left to its own devices, a member of the electronics industry would probably accept automatic production when it felt it could better its competition by doing so or fall behind the competition by not doing so. While these reasons are plausible from the business standpoint, there are military and economic factors that enter the picture and, as such, must also receive consideration.

Military Need for Automatic Production. A current military problem is that of having vast quantities of electronic equipment when needed. A similar problem faced this country at the beginning of World War II, when industry could not produce enough radar, sonar, communications equipment, and other such devices with sufficient rapidity. /4/ Planes were sent into combat and warships into battle zones without vital electronic equipment, with the result that in far too many instances, the armed forces fought World War II with World War I arms.

At the present time, there is a considerable difference between the population of our country and that of our potential enemies. To offset this difference, we must capitalize on our technical skill and industrial might, so as to multiply each man's effort to a high degree. Machinery must be developed whereby a military electronic device developed today can be put into high production within a few weeks instead of the months and years which have been necessary.

With the ever-increasing uses of electronics, and the astronomical quantities needed for any future war, it is painfully evident from available statistics that sufficient factory workers will not be available.

The production so necessary for our survival will be possible only if the current output per worker can be increased.

Economic Need for Automatic Production. The economic need is well stated in a recent report published by the General Electric Company. /5/ According to this report, economic and industrial analysts conclude that to maintain the present rate of increase of living standards in this country, the output of goods and services per worker must increase by 43 percent between 1950 and 1960. The major portion of this increase can only come through new developments, such as automatic production.

Laborsaving Techniques. Today, then, both military urgency and economic motives demand more fully mechanized construction, and newly developed techniques have provided a good start in this direction. /6/ Some of the methods applicable to lessening labor requirements in electronic equipment manufacture are listed below. It will be noted that the first two items represent older methods, the use of which is being extended on modern equipment. The latter four items, however, represent substantially new trends.

1. Mechanized component construction
2. Division of equipment into subassemblies
3. Multiple-component units
4. Prefabricated circuits
5. Components of specialized form
6. Mechanized connection of components

Mechanized Component Construction. For a long time American production of electronic components has employed mechanized processes to a significant extent. Steady progress has been made during and since the war in this direction. Examples are improved machinery for winding paper capacitor elements, and for processing and testing resistors. The now popular high dielectric constant ceramic capacitors represent newer components inherently well adapted to mechanized processing. A more radical departure from conventional practice is represented by a large production machine for building vitreous enamel capacitors. /6/ It is believed by some that machines of this type might be modified to produce a variety of components and small assemblies thereof.

Division of Equipment into Subassemblies. A well established method of facilitating production is to divide an equipment into subassemblies, thus providing for ready access and for specialization among factory workers. Present trends to the use of packaged subassemblies are consistent with retainment of the production advantages of the subassembly approach. In the nonmechanized production of some of the modern hearing aids, the subassembly device is used, since provision must be made for accessibility.

Multiple-Component Units. The rapidly increasing use of functional multiple-component units, which contain two or more capacitors, resistors, inductors, miniature sockets, and other elements, constitutes a most satisfying trend, contributing to reduction in time and manpower requirements in the electronics equipments manufacturing plants. The trend to the use of such units in assembly has several desirable attributes. Part of the traditional assembly function is taken from the equipment manufacturing plant and placed in the component manufacturing plants, where there is greater experience in the use of mechanized construction techniques. Tendencies to standardize the use of such functional units as these should result in a still greater degree of mechanized construction. The more complex of the multiple component units are already being produced by printed circuit techniques.

Prefabricated Circuits. Without question, printed circuit techniques will ultimately contribute extensively to the possibilities of mechanized manufacture of electronic equipment, and there is definite possibility that substantial portions of circuits may be fabricated by methods similar to present printed circuit techniques. At present, the comprehensive manufacture of components in circuits does not appear ready for adoption in mass production.

Components of Specialized Form. Work on specialized components has already made possible a reduction in the amount of labor required to insert them into prefabricated panels by hand. Examples of such developments are the use of leadless components, such as tubular or rod resistor units; the common use of leadless ceramic capacitors; the use of flat "tape" resistor elements; and the use of components with their leads bent at right angles.

Mechanized Connection of Components. Soldering of the connections, once the components have been mounted in the prefabricated circuit panels, can be accomplished in the conventional manner, using a soldering iron, much more readily than can the corresponding operation be carried out in the jumble of components on the traditional-type chassis. Of considerable interest, however, is the process of dip-soldering. /7/ In the assembly of components to prefabricated circuit panels, the connections to each panel may be dip-soldered in one operation by placing the assembly, with the prefabricated circuit side of the panel down, upon a molten solder bath. This particular operation is discussed in greater detail later in the chapter.

## DIFFERENT PHILOSOPHIES

Once the idea of full mechanized production has been accepted by the electronics industry, the next logical step is to determine what system or philosophy should be used. Generally, it may be assumed that almost anything can be mechanized — at a price. Even such intricate components as electronic tubes are produced by machine. /8/ The problem with

regard to electronic equipment assembly, however, is one of providing mechanization along with flexibility, so that different assemblies may be produced in short as well as long runs. Because of the recognized scope, complexity, and import of this problem to military electronic production, parallel investigations have been conducted by the several services.

In general, the findings of these investigations seem to represent two distinct schools of thought. One school represents a revolutionary break with existing techniques, in that practically all new components and assembly techniques are employed. The second school of thought proposes a plan that is more evolutionary in nature. Utilizing presently available techniques, such as those outlined previously, it proposes to build existing component parts into sub-assemblies by mechanical means.

No attempt will be made to review all programs under way or being contemplated. Two well publicized systems, however, will be discussed, Auto-Assembly and Tinkertoy (the latter now given the unwieldy designation of "Modular Design of Electronics" and "Mechanized Production of Electronics"). These two systems were selected because (1) they differ rather markedly in their basic philosophies, and (2) they are representative of the trend the automatic production of electronic equipment seems to be pursuing.

It would be presumptuous at this time to make a prediction as to which philosophy will be the most successful. Many of the systems are still in the development or prototype stage and further studies have to be carried out. The current state of the art can be judged by the fact that the first symposium on the automatic production of electronic equipment was held in 1954. /9/ It can be predicted, however, that aided by the genius of our present and future designers, and influenced by such factors as the cost of capital equipment and the attendant cost of supervision and maintenance, the electronics industry will adopt those methods which common sense and dollars indicate as best suited in each particular case. In combination, these factors are most powerful.

## PROJECT TINKERTOY

Sponsored by the Navy Bureau of Aeronautics, the National Bureau of Standards began a study program in 1950 to ascertain the feasibility of mechanizing the construction of electronic equipment. The result of this study was Tinkertoy, an automatic production line for the manufacture of electronic products, and a novel system of electronic design. /10/

Project Tinkertoy employs a design system called MDE (Modular Design of Electronics). This system establishes a series of mechanically standardized and uniform modules (or building blocks), which are producible with a wide range of electrical characteristics. Each module, in general, consists of some four to six thin ceramic wafers, bearing various circuits associated with an electronic stage. A num-

ber of individual modules are combined to form a major subassembly.

Utilizing, for the most part, noncritical raw materials, the production of modules and assemblies is achieved mechanically in a system called MPE (Mechanized Production of Electronics). This production line produces all the large-quantity parts except the tubes. The joining of modules together to form subassemblies may also be accomplished by machines.

#### NOTE

Those unacquainted with the details of Project Tinkertoy are referred to the material in the bibliography, and in particular to the November issue of the NBS Technical News Bulletin. This NBS publication gives a clear, step-by-step description of the entire system.

Advantages of Project Tinkertoy. Project Tinkertoy makes possible a rapid conversion from civilian to military products (and back again) on short notice and, concurrently, allows a greatly expanded production capacity. Delays caused by the need for recruiting and training new production personnel and the procurement of new mechanisms and parts are eliminated. Most of the operating "know-how" is stored in mechanical fingers and electromechanical control mechanisms, and even electronic equipment designs may be stored, ready for production, in the form of punched cards and circuit stencil screens.

Because it largely utilizes unprocessed or bulk materials, the system is comparatively free from dependence on particular components in critical supply. The Mechanized Production of Electronics results in a very high production rate. Uniformity of electronic products at a high quality level is enhanced by the mechanized production and by 100 percent automatic inspection. This affords the possibility of repair and maintenance of electronic systems by replacement of unitized packages or entire subassemblies.

Performance of equipments produced appears generally equivalent to that obtainable from conventional assemblies. Equipments produced on an experimental basis meet military environmental requirements, passing such tests as shock, vibration, temperature, and humidity established in military specifications. Moreover, the standardization and uniformity achieved by the MDE wafer-component and stacked-wafer design result in production outputs of uniformly satisfactory equipment, whose characteristics, both physical and electrical, are controlled through the 100 percent automatic inspection machines that are an integral part of the production line.

#### AUTO-SEMBLY

The problem of utilizing presently available techniques for the production of representative electronic devices has been studied by the Signal Corps

Engineering Laboratories (SCEL), who have formulated the interesting "Auto-Semby" method of construction. /9/ This method proposes assembly of conventional components to printed conductor patterns by dip-soldering. A given piece of equipment may employ several such panels assembled into decks, which are spaced apart in the overall assembly precisely as are the decks of a ship, with headroom for the components determining the deck spacing. Longer decks, as need be, provide for components that project unduly far from the mounting panel. Interconnecting pins are inserted into the decks, where they are secured in the same manner as are other components. These inter-panel connectors make the circuit, as well as the physical assembly, three-dimensional. An assembly made up in this manner may be housed or packaged by any of the usual methods. It is contemplated that casting resin embedment may often prove appropriate to secure firmly all components and panels against shock and vibration, as well as to provide hermetic sealing.

#### NOTE

For a more complete description of the Auto-Semby system, the reader is referred to the bibliography material and in particular to the special report prepared by the General Electric Co.

Advantages of Auto-Semby. In most industries, progress is a slow, gradual act. Radical change or advancement is often a financial hazard. In this respect, Auto-Semby has the advantage of being more evolutionary than Tinkertoy. It makes use of existing automatic know-how, rather than discarding it. It employs timetested components, which are produced by competing companies and designed to meet current military specifications. The automatic know-how and approved component parts are available today — they do not have to be developed.

Dip-Soldering. It might be well to discuss here a phase of current automatic know-how in order to highlight the advancements some of these techniques have made. One of the country's large producers of electrical appliances has employed an automatic dip-soldering machine in the manufacture of its television receivers since 1949. The present machine, with a rated capacity of 350 chassis units an hour, handles a 13 1/2-inch square chassis containing 424 terminal pins, each having from 1 to 4 leads. This machine consists of a flux tank, a solder tank, and an endless chain conveyor that travels over the tanks and auxiliary equipment. Cold solder is dropped into a receptacle at the rear of the machine, where it is heated to the desired temperature and then automatically fed into the solder pot at a rate designed to maintain a constant solder level. As a chassis comes off the assembly line, it is fitted into a rack on the chain conveyor, which then automatically lowers it first into the flux tank and then into the solder tank.

The conveyor stops, dwell time in the flux and solder tanks, and so on are controlled by a series

of snap-action switches and delay relays. The solder tank is maintained at a temperature of 600 F by means of a thermostatic control. Since dross must be skimmed off the hot solder surface each time a chassis is dipped, wiper blades are built into the rear of each chassis-holding fixture to accomplish this as the fixtures pass over the solder tank. Fumes from the operation are carried off by a hooded exhaust system installed over the machine.

When the soldering operation is completed, the chassis is removed from the chain conveyor and placed on a shaker table. Vibration not only shows up imperfections in the dip-soldering job but also cleans out scraps that may have fallen in the chassis during assembly.

According to K. M. Lord /7/, the following advantages have resulted from the employment of this process:

1. Increased reliability of the finished products. The hundreds of connections involved in this modern electronic unit are made with absolute uniformity in respect to the amount of solder used and the degree of temperature applied. This means a consistent, reliable chassis, resulting in superior performance. By eliminating the danger of overheating, component failure in finished receivers is sharply reduced.
2. Less wiring is required. This minimizes such problems as establishing and maintaining lead-dress and spacing in the closely packed and complex interior of the equipment.
3. Tools are not required in the manual positioning of components, in contrast to the need for crimping pliers, soldering irons, and other tools required in the assembly of the conventional chassis.
4. The time required to train personnel on the assembly line has been reduced.
5. Employee morale is improved. With the elimination of the hand soldering iron, the work is cleaner and much less tiring. Irritation from flux fumes, which accompany hand soldering, is completely absent.
6. Manufacturing costs have been reduced through the lessening of the possibility of damage to components and the margin of error in the assembly operation has been cut.
7. The reduction in the amount of wiring means an increase in the space available for components and aids immeasurably in

parts standardization.

8. Service costs to the consumer are reduced. The serviceman, in breaking one connection of a hand-soldered television receiver, may find it necessary to remove three or more individually soldered connections with several applications of heat. In a dip-soldered chassis, the service operation can be accomplished with a single touch of the soldering iron. This reduces the possibility of heat damage to delicate components, speeds up the repair job, results in lower repair costs to the owner, and causes less disturbance to the basic balance of the circuit.

Advantages such as those enumerated above, available in current production methods, are very strong advocates for the Auto-Semby method.

#### REQUIREMENTS FOR THE AUTOMATIC PRODUCTION OF MILITARY ELECTRONIC EQUIPMENT

In attempting to evaluate the advantages of Tinkertoy with those of Auto-Semby, it would be wise to consider just what requirements a system for the automatic production of military electronic equipment must meet. The manner and degree by which the two different systems satisfy these requirements may well determine which form of automatic production will prevail.

Flexibility. A primary concern of any such system is flexibility. The majority of units and sub-assemblies forming complex military electronic systems are manufactured in short run quantities. Electronics is such a fast moving art, that frequent design changes and circuit improvements are normal. Quantities of over 1,000 are unusual; the average may be around 50, and quantities as low as 20, or even 10, are not unusual. An automatic assembly system for military electronic equipment should, therefore, be designed to operate most efficiently in this quantity range. At the same time, it should lend itself to economical manufacture in reasonably large quantities. It should also be designed so that setup or preparation time and effort required to get a given assembly into production, or to change from one assembly to a completely different one, are at a minimum. Also, it should permit design changes in the assembly being made with minimum shutdown or delay. Furthermore, the cost of the machinery in the line should be in keeping with the quality and quantity of the finished product.

Conclusive information is not available at this time as to which of the two systems offers the greatest flexibility.

Mobility. For maximum effectiveness as an industrial preparedness measure, it is important that the design of the individual machines and parts making up the system be such that the machines and system may be readily dismantled, stored, and shipped, and

then quickly set up and put into operation at a new location.

Here again, precise information is not available as to which of the two systems will offer the greatest mobility.

Degree of Mechanized Operation. This, of course, is one instance where the difference in philosophy between the two systems is very apparent. The philosophy behind the Auto-Semby system might be stated as follows:

In mechanizing complex processes, such as those involved in the fabrication and assembly of electronic equipment, considerable skill and a great deal of judgement must be exercised in determining how far to go in making a process automatic. Many of the advantages of automatic production may be realized without necessarily making the machine or process 100 percent automatic. In fact, the complete mechanization of certain operations may be completely impractical, or at least initially uneconomical.

Rather than overcomplicate a special machine or system, and greatly delay its development, in an attempt to handle all conceivable variables and achieve 100 percent mechanization at the start, it is usually better to settle for something less than 100 percent and leave the special cases to be handled manually or by separate, special machines. It is important, however, that the design of the complete system be left "open-ended" insofar as possible, so that mechanization of the remainder at a later time can be fitted into the overall system with minimum change or disturbance to the basic design.

The Tinkertoy philosophy might be expressed as follows:

In deciding how far to go in making a process or system automatic, it is suggested that the lessons learned in the electronics industry itself be taken as a guide. Here, mechanization has been applied on a piecemeal basis for some time, and the results to date cannot be called spectacular. Such mechanization as does exist has frequently been developed by individual firms to satisfy their individual needs, with the result that these processes are not always applicable to the rest of the industry or compatible with each other.

Tinkertoy, on the other hand, is a thoroughly mechanized system, each step of which is compatible with the next. Through the use of the modules and ceramic wafers, product standardization and uniformity, which are a prerequisite for any automatic machine, are made an integral aspect of the lineup. This standardization and uniformity exists today – it does not have to be developed.

Standard vs. Special Components. Here is the second point on which the two systems differ basically in their philosophies. The proponents of Auto-Semby contend that, driven by stiff competition and aided by

clever design, the manufacturers of component parts have developed their product to a high degree of perfection, that these components are now available, and that their continued improvement can be expected. They further point to the difficulties of producing components in a single line that manufactures, tests, and assembles electronic equipment.

In rebuttal, it may be said that component parts are one of the first items to be in short supply during a national emergency, and that any mechanized system that cannot help alleviate this situation has only half solved the problem of the automatic production of electronic equipment. The Tinkertoy line produces all its own large-quantity component parts, with the exception of tubes, and does so by using noncritical raw materials. There is also every reason to expect that the quality of these components will improve with further development.

Conclusion. To summarize, it can be said that the automatic production of electronic equipment offers the following advantages:

1. Increases the output per worker.
2. Reduces the time required to train operators. A properly designed automatic production system can greatly reduce the lead time required to get into full production, since the machine can be programmed to perform the proper operations at maximum capacity before it is set in motion.
3. Helps avoid labor shortages during national emergencies by requiring a minimum number of skilled workers.
4. Increases the efficiency of production. Unlike the variable human being that it replaces, a machine does not get tired, strained, or bored – nor does it have to eat or rest. In fact, a machine can operate for 24 hours a day for long periods, if necessary.
5. Improves the quality of the product. Once properly set, a machine will repeat many thousands of operations with the same precision with which it performed the first. This better quality will insure better reliability.
6. Reduces the cost of manufacture through the elimination of direct labor operations combined with increases in quality and machine efficiency. /11/

It seems fairly certain that all component parts will go through some form of evolution that will make them more adaptable to an automatic process. Equipment design will probably undergo a more rapid change to take fuller advantage of subassemblies and

automatic processes. Assuming that the trend of using hermetically sealed subassemblies will continue, attention must be given to mechanizable means for these types of packaging. It appears evident that hermetic sealing through use of resin embedment is likewise amenable to mechanized production and should cost less than metal containers. Additional test points will probably be required within an equipment to provide a more thorough circuit check and a more complete testing.

Regardless of the changes that occur, the electronic designer must be thoroughly aware of the advancements in automatic processes and must be prepared to take full advantage of them in his work.

## MINIATURIZATION

As previously pointed out in the chapter on Mechanical and Environmental Factors, the number of functions being performed electronically is becoming so great and their operation so complex, that the utility of electronic equipment is being seriously threatened by sheer bulk. /12/ From the logistics angle, any reduction of weight and size will mean tremendous savings in transportation, both for military and commercial purposes and necessary stockpiles of strategic and critical materials can be reduced.

Major Problems. In the past, the primary requirement of the electronics engineer was to develop an operating circuit and to engineer it for production at a competitive level. Miniaturization, if any, was incidental and was achieved mainly through the use of smaller components, if and when they became available. The component engineer, in turn, depended largely upon the development of new materials for his success in miniaturization. New materials were, however, in the province of the chemist, metallurgist, and physicist, who in general were not particularly concerned with, or cognizant of, electronic requirements.

Fortunately, enough wartime requirements, such as the proximity fuze, had the element of size so intimately linked with the performance requirements that miniaturization could not be overlooked. As a result, impetus was applied to the full-scale development of subminiature tubes, and with their availability, psychological barriers to miniaturization began to disappear at an increasing rate. Design engineers have been placing greater demands upon the component engineers and are working even more closely with them. Shapiro reports that the development of 14 new components enabled NBS to design a 12-tube receiver that occupied 55 cu in. /13/ Both design engineers and component engineers in turn are adopting a more active attitude toward the materials engineer. Rather than wait passively for a new material, and then see how it could be used electrically, more and more requirements are being placed for the development of new materials with specific electrical properties.

Production. From the production standpoint, the design engineer must remember that the assembly,

test, and inspection of miniaturized equipment is a somewhat specialized technique. Figure 10-1 shows the type of tools now required for working on miniaturized

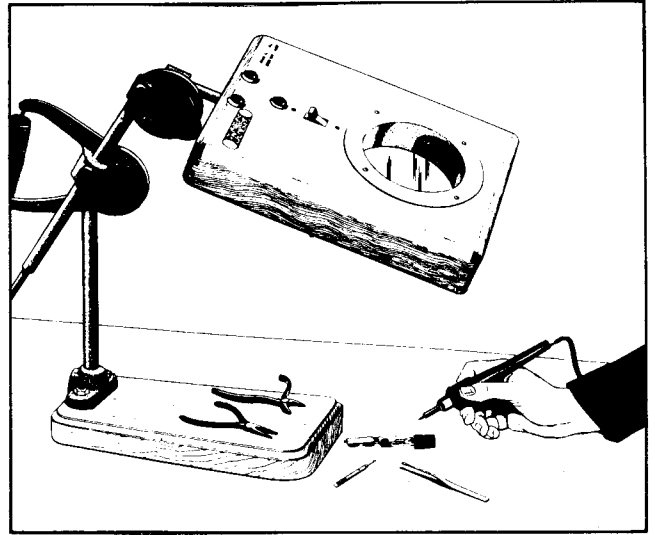

Figure 10-1. Magnifier and tool types required for work on miniature unitized assemblies

units, using present techniques of assembly. It can be seen that the production problem is similar to that encountered by the instrument and watchmaking industry. This by no means implies that the electronic industry could not adapt itself, but it does definitely mean that assembly and inspection personnel will require more training; in some cases personnel with special aptitudes will have to be selected. Such personnel will be more expensive and, in an emergency, it is highly questionable whether they will be available in sufficient numbers, or whether they can be trained rapidly enough.

A current approach to this problem, which greatly excites the imagination, is to devise production processes that do not require this extensive handling of individual components and their hand assembly into equipments. Such a radical change from established production procedures and assembly line techniques, of course, raises additional new problems, but these are by no means unsurmountable. Any new assembly technique, however, must successfully meet these problems if it is to be acceptable to the electronics industry.

There are at present three assembly techniques that have established themselves as being conducive to miniaturization. They are unitized or cellular construction, printed circuits, and casting or encapsulation. These techniques, along with automation, are discussed elsewhere in this book.

## REFERENCES

1. Brunetti, Cleo, T. R. James, and E. R. Van Krevelen, "Automatic Production in the Electronics Industry," Airborne Electronics Symposium, Dayton, Ohio, 1954.
2. Gerhold, R. A., "Printed Circuits and the Automatic Factory," National Electronics Conference, Chicago, Ill., September 30, 1952.
3. Mechanized Production of Miniature Electronic Packaged Subassemblies Using Modular Construction, Final Report - Letter Contract: NObs-5235, Melpar, Inc., Alexandria, Va., February 28, 1953.
4. Rives, Tom C., Brigadier General, U. S. Air Force (Retired), "Automation for Survival," Proceedings, Symposium on Automatic Production of Electronic Equipment, San Francisco, Calif., April 1954.
5. Automatic Component Assembly System, Special Report, supplementing Quarterly Report No. 2, General Electric Co., February 25, 1954, Electronics Park, Syracuse, N. Y.
6. Electronic Equipment Construction (New Objectives - New Techniques - New Components), Terminal Report, June 1, 1950, Contract No. N7onr-32103, Stanford Research Institute, Stanford, Calif.
7. Lord, K. M., "Mechanized Dip Soldering of Television Receivers," Electronics, June 1953.
8. Gerhold, R. A., "Auto-Semby: Basis for Automatization of Electronic Equipment Production," text of paper delivered at OCSigO, Washington, D. C., March 9, 1954.
9. Symposium on Automatic Production of Electronic Equipment, sponsored by Stanford Research Institute and U. S. Air Force, April 19 and 20, 1954, Fairmont Hotel, San Francisco, Calif.
10. "Project Tinkertoy," NBS Technical News Bulletin, November 1953.
11. Warriner, Ben, Considerations in the Automatic Assembly of Components, General Electric Co.
12. Jacobs, Yale, "Fundamentals of Electronic Equipment Miniaturization," AF Technical Report No. 6105, Wright-Patterson Air Force Base, Dayton, Ohio.
13. Shapiro, Gustave, "Subminiaturization Techniques for Low-Frequency Receivers," NBS Circular 1945.

## BIBLIOGRAPHY

- Automatic Component Assembly System, Special Report, supplementing Quarterly Report No. 2, February 25, 1954, General Electric Co., Electronics Park, Syracuse, N. Y.
- Brunetti, Cleo, T. R. James, and E. R. Van Krevelen, "Automatic Production in the Electronics Industry," Airborne Electronics Symposium, Dayton, Ohio, 1954.
- Danko, S. F., "Compact Assembly Methods," Proceedings of Symposium, Progress in Quality Components, May 5, 6, and 7, 1952, RTMA, 777-14 St. N.W., Washington 5, D. C.
- Danko, S. F., and S. J. Lanzalotti, "Auto-Semby of Miniature Military Equipment," Electronics, July 1951.
- DeVore, Charles, "New Method for Electronics Production," Signal, November-December 1953.
- Electronic Equipment Construction (New Objectives - New Techniques - New Components), Terminal Report, June 1, 1950, Contract No. N7onr-32103, Stanford Research Institute, Stanford, Calif.
- Gerhold, R. A., "Auto-Semby: Basis for Automatization of Electronic Equipment Production," text of paper delivered at OCSigO, Washington, D. C., March 9, 1954.
- Gerhold, R. A., "Printed Circuit Assemblies by Automatic-Machine Systems," Electrical Manufacturing, March 1953.
- Gerhold, R. A., Printed Circuits and the Automatic Factory, Signal Corps Engineering Laboratories, Fort Monmouth, N. J.



**BIBLIOGRAPHY (cont)**

Henry, R. L., and C. C. Rayburn, "Mechanized Production of Electronic Equipment," Electronics, December 1953.

Klass, Philip, "Experts Study Progress in Automation," Aviation Week, March 8, 1954.

Mechanized Production of Miniature Electronic Packaged Subassemblies Using Modular Construction, Final Report - Letter Contract: NObs-5235, Melpar, Inc., Alexandria, Va., February 28, 1953.

"Printed Circuit Information Within SCEL," Information Bulletin 165A, Components and Materials Branch, Squire Signal Laboratory, Fort Monmouth, N. J.

"Project Tinkertoy," NBS Technical News Bulletin, November 1953.

Rives, Tom C., Brigadier General, U. S. Air Force (Retired), "Automation for Survival," Proceedings, Symposium on Automatic Production of Electronic Equipment, San Francisco, Calif., April, 1954.

Symposium on Automatic Production of Electronic Equipment, sponsored by Stanford Research Institute and U. S. Air Force, April 19 and 20, 1954, Fairmont Hotel, San Francisco, Calif.

Warriner, Ben, Considerations in the Automatic Assembly of Components, General Electric Co.

# CONTENTS

## chapter eleven **equipment publications**

Relationship Between Designer and Writer

Designer's Responsibility for Equipment Publications

Types of Equipment Publications

Equipment Manual Specifications

Necessary Information

Proper Liaison

Time Element

# chapter 11

## EQUIPMENT PUBLICATIONS

In the preceding chapters, various aspects of reliability have been discussed and, to a large extent, found to be technical problems that usually involve the design engineer. Now we shall consider a phase of reliability which, though semi-technical in nature, still requires the consideration of the electronics designer. This is the preparation of equipment publications.

It is axiomatic that the reliability of the finest electronic device is limited by the educational level, the skill, and the developed techniques of the people who operate and maintain the equipment. Unfortunately, we do not have enough educationally equipped personnel to operate the complicated gear that plays such a vital part in our military machine. The prospect of rectifying this situation in the near future is not particularly encouraging nor, for that matter, is the situation likely to improve during a national emergency.

Much of the equipment produced today requires specialized talents on the part of the user. This was not a serious obstacle to overcome during normal times, when only a few units of such equipment would be produced. Personnel could be properly screened, selected, given special training, and then sent into the field to operate the equipment. Such a program, however, rapidly disintegrates during periods of national stress. The production of equipment is greatly increased, personnel screening is relaxed, or eliminated, training periods are shortened, and so on.

Added to all this is the fact that even if the trained personnel are available with the proper educational background, the complexity of today's electronic equipment is often so great that no amount of training can adequately cover the entire field. Additional sources of information must be available.

What are the responsibilities of the elec-

tronics designer in a situation such as this? What can he do to help improve the situation? It is the purpose of this chapter to show how the engineer may improve the reliability record of his design through the more efficient use of a form of technical literature – namely equipment publications.

Technical literature is one of the most important media of communication and education at the disposal of the engineer. Just as he is able to learn of the mistakes and progress of others through this source, so, too, he is able to share his own knowledge with others. Unfortunately, however, equipment publications often fail to achieve their purpose because the needs and limitations of the readers are not considered by those who help prepare them. It should be realized that technical manuals are a medium of communication. These books should bridge the gap that exists between the knowledge of the man who designed the equipment and the knowledge of the man who must operate and maintain it. To span such a gap effectively, one must build a bridge of information on solid foundations of absolute accuracy and with the strength of absolute clarity. It is fatuous to believe that it is merely necessary to get rough ideas or sparse information into print to obtain the desired results.

### RELATIONSHIP BETWEEN DESIGNER AND WRITER

The complexity of electronic equipment design is so great that the writer who prepares the equipment publications usually has had nothing to do with the development of the particular design. In fact, at the beginning of his job, he may know only the formal name and number of the project. Strange as it may seem, this situation is not undesirable, but offers a distinct advantage. The writer is completely free from experiences connected with the metamorphosis of the equipment, and is primarily interested only in its final form. With the proper engineering background, he can learn every essential fact relating to the new equip-

ment. This very process is the one he must duplicate in the manual. He cannot help but recall the individual steps in his investigation which, in sequence, provided him with a full understanding of the functions and physical characteristics of the equipment. He knows which parts proved confusing and what ideas crept into place at the right time.

All this is predicted on the supposition that the correct engineering data was available at the proper time. Since the writer did not take part in the development of the equipment, he is not in a position to expand those areas where little or no engineering data is available, where the theory of operation is in doubt, or where the information given is vague or misleading. In short, the quality of the equipment publications may well be determined by the information and engineering data the designer gives the writer. A good manual may be prepared from good engineering data, but it is next to impossible to prepare a good manual from poor engineering data. An accurate manual from inaccurate raw material is an utter impossibility.

Reliable equipment publications must be just as carefully "engineered" within their field as the equipments they concern. This calls for important decisions on such matters as editorial policy, the number and kind of illustrations, the style and size of type, the quality of paper, and the type of binding. These are all decisions that fall outside the scope of responsibility of the design engineer - he should not be bothered with such details, nor should he involve himself in them. In other words, it is the duty and responsibility of the electronics engineer to design the equipment, and the duty and responsibility of the writer and his staff to prepare and publish the book. Each field is a specialty and requires the work of a specialist. The end product of equipment reliability, however, calls for cooperation and compromise between these two specialists.

#### DESIGNER'S RESPONSIBILITY FOR EQUIPMENT PUBLICATIONS

For the sake of emphasis let the statement be repeated that the electronics designer should neither assume nor be burdened with the additional responsibilities of a writer. But since the information for the manuals must originate primarily with the engineer, does it not seem apparent that the designer must be acquainted with some of the aspects of equipment publications, if his knowledge on a particular piece of equipment is to be properly communicated to those who will ultimately use this equipment? For this reason, the following suggestions are offered to the designer in order that he may properly perform his duties with regard to equipment publications.

1. The designer should be acquainted with the various types of equipment publications that will be used in conjunction with his equipment.
2. The designer should be acquainted with

the specifications that govern the equipment publications.

3. As a matter of course, the designer should provide the writer with all necessary information.
4. The designer should see that proper liaison is established and maintained between his staff and the writer and his staff.
5. The designer should be conscious of the time element that may exist between the date the manuals are slated to begin and the date the equipment is finally produced.

#### TYPES OF EQUIPMENT PUBLICATIONS

Publications for Air Force electronic equipment generally fall into two main categories, electronic equipment publications and test equipment publications. In a few instances, the latter may be incorporated in the first. Information supplied by equipment publications consists of instructions on operation and maintenance of equipment. Existing specifications usually require this information to be presented in four books, (1) operating instructions, (2) service instructions, (3) overhaul instructions, and (4) parts lists.

Operating Instructions. Operating instructions are intended to help the operator use the equipment intelligently. Both the designer and writer should realize that the operator may have a minimum of technical knowledge and, in fact, does not have to be an engineer to be a successful operator. Taking into consideration the operator's technical background and the limited availability of tools, this publication should give such information as the proper procedure for starting, operating, and shutting down the equipment, and limitations of the equipment. The amount of theory that is presented in these publications is frequently determined by the requirements placed upon the operator. Usually more theory is presented for those equipments that require personal interpretation on the part of the operator. In those cases where the operator is only required to perform mechanical or routine functions, little or no theory may be given.

Service Instructions. Service instructions cover organizational and field maintenance performed by personnel who directly support the unit using the equipment. In general, these personnel have a much better maintenance background than do operators, but it should be remembered that they may have had no previous experience with the specific equipment, and may be handicapped by the lack of special tools. Field technicians usually can replace malfunctioning or unserviceable parts, if spares are in stock, but they seldom repair such items. Service instructions should enable maintenance personnel to locate the source of trouble and to remedy the difficulty if facilities are available.

**Overhaul Instructions.** Overhaul instructions should provide detailed information for major modification, repair, or complete rebuilding of the equipment. This work usually takes place at overhaul depots where specially trained personnel may work with the proper tools. This publication should enable the user either to repair damaged equipment or to salvage usable components, which may then be used for spare parts.

**Illustrated Parts Catalog.** Parts lists or illustrated parts catalogs are intended to help locate and identify parts and to provide proper information for ordering replacements.

**Test Equipment Publications.** Maintenance of electronics equipment frequently calls for specialized test apparatus. Such apparatus in turn requires special publications (operating instructions, service instructions, and so on), which are similar in scope and purpose to the manuals for electronic equipment. However, it is usually the operator of the test apparatus who is responsible for its maintenance.

#### EQUIPMENT MANUAL SPECIFICATIONS

The designer must remember that, just as he had to follow certain government specifications in building his equipment, so, too, must the writer follow certain specifications in the performance of his duties. These manual specifications may not necessarily follow the logical engineering development of the equipment. If the designer is acquainted with these specifications, he will be less likely to make unrealistic demands upon the writer as to manner in which the information is presented.

#### NECESSARY INFORMATION

A properly qualified writer cannot be given too much information on a particular job, and for the engineer arbitrarily to decide what information is necessary and what information is unnecessary will not produce the best results. Though many designers may disagree with this statement, it is suggested that those who do, ask themselves the following questions the next time they prepare to withhold information from the writer:

1. How difficult is the equipment to operate?
2. How difficult is it to maintain?
3. What information do the people who operate and maintain this equipment need?
4. Has the writer been provided with sufficient information so that the what, when, where, why, and how of equipment operation and maintenance can be properly described?

Though the requirements for the various publications

will differ from equipment to equipment, it is recommended that all of the following information be made available to the writer:

1. A complete set of manufacturing drawings
2. Test specifications
3. Bill of materials
4. Engineering change notices
5. A copy of the specification to which the equipment was built.
6. Photographs – if any

It goes without saying that, if possible, this information should be made available at the start of the job, and that it must be technically accurate. It should also be consistent. Different designers, for example, may have their own pet titles which do not agree with official nomenclature for the various parts of the equipment. If these names are not corrected, confusion will result and time will be wasted.

#### PROPER LIAISON

One responsibility that the designer should not hesitate to assume is this—he should see to it that proper liaison exists between himself and the writer. Yet it is surprising how frequently such channels do not exist. All too frequently, the designer is prone to look down upon the writer as a necessary evil, forgetting that the final reliability of his equipment may well rest upon the production of this man.

The designer should also be responsible for the conferences that are held with the writer. During the preliminary conference, the equipment operation should be discussed in general, touching on those areas that may be especially critical or sensitive. To overwhelm the writer with too many details at this first meeting, so that future ones are unnecessary, is only to defeat the entire purpose of the conference. The number of subsequent meetings should be determined by the complexity of the equipment and the number of legitimate questions that may arise.

#### TIME ELEMENT

Ideally, equipment publications should not be started until the equipment itself has been produced. The operating procedure has then been established, the various resistance values, voltage readings, and so on, have been finalized, and the writer may work with a complete set of final drawings. But in practice, this situation does not always exist, because it is frequently necessary to send out the manuals at the same time the equipment is being shipped. It takes very little imagination to realize how difficult it is to prepare a publication under such conditions.

To help remedy this situation, it is recom-

mended that the designer set a freeze date for a certain part of the equipment and allow the writer to finish all material relating to this section. The various other parts of the equipment should then be treated in a similar manner until text has been prepared for the entire equipment. When the equipment design is at last frozen, these various sections will have to be revised, but at least some progress will have been made and a considerable part of the groundwork may have been accomplished.

#### CONCLUSION

In conclusion, it may be said that the respon-

sibility for good equipment publications is the joint concern of the designer and the writer. It is the responsibility of the designer to make the information available to the writer, and the writer's responsibility to present this information in a correct, readable style. The designer knows better than anyone else the demands, limitations, and reliability of the equipment. He must see to it that the information in the final publication is accurate and correct.

Better technical publications will increase the reliability of the equipment, and it is just as important to have reliable equipment publications as it is to have reliable equipment.

# CONTENTS

## chapter twelve **maintenance**

The Techniques

Value of Fault-Locating Techniques

Failure Prediction

Marginal Testing

Built-in Test Equipment

Design Considerations

Familiarity as a Time Saver

Accessibility

Complaints on Poor Accessibility

General Considerations

# chapter 12

## MAINTENANCE

The prime object of building greater reliability into military electronic equipment is to ensure that the equipment is in the required working condition at the required time. A secondary, but very important, object of greater reliability is to ease the manpower problem for maintenance. In military usage, these manpower requirements must be keyed to the peak rate of failure and not to the average rate of failure. The equipment must be serviced when it breaks down, not at the convenience of a radio serviceman around the corner.

It has been estimated that one man can service equipment having 250 tubes; a 2,500-tube equipment, therefore, would require 10 men just to keep the equipment at the required operating condition at the required time. This load, based on a peak rather than an average failure, is a burden of extreme proportions.

By means of certain technical tricks the peak load of emergency maintenance can be reduced; but, if this merely means that just as many man-hours are required for preventive maintenance or pre-fault testing, the total number of man-hours has not been decreased — it has been shifted in time. The bald truth is that maintenance must be reduced. Every man-hour saved from the maintenance burden is a man-hour available for more important, more productive, more interesting, and more inspiring work. The maintenance job, from the morale standpoint, is like the job of the garage mechanic — fixing up someone else's car so that someone else can have a good time.

The job of the reliability engineer, therefore, is to produce equipment that is inherently more reliable; that is, equipment requiring fewer man-hours for maintenance of any sort; and to produce equipment which can be serviced easily and quickly so that a

given number of man-hours will take care of more equipment.

The whole purpose of the chapters so far presented in this handbook is to help designers produce equipment that is inherently more reliable. The purpose of this chapter is to indicate some of the newer techniques and philosophies that have been developed to make the maintenance job easier and quicker, without excessive use of skilled manpower.

**The Techniques.** Up to within recent years, the maintenance job had two aspects only, preventive maintenance, by which routine schedules were performed on some sort of time basis; and emergency maintenance, by which the equipment was put back into proper condition once a failure had occurred. Much study has been given to these servicing aspects, both as to the human engineering involved and as to the actual efficacy of the techniques heretofore used to determine if they could be improved. These studies continue.

"To reduce the peak load of emergency maintenance three things must be done. First, fault-locating devices of sufficient sensitivity to anticipate failures must be devised. Thus incipient failures might be removed before they occur; this converts some of the emergency maintenance to routine maintenance. Second, fault-locating devices and panel layouts must be devised which will speed emergency maintenance by enabling the skilled technicians to work faster. Third, a system of replaceable packaging must be developed to permit deferment of some of the repairs. . . to a more convenient time." /1/

Fault-locating devices can be utilized to speed the process of finding where the trouble is after it has occurred and, better, to locate incipient troubles before they occur. In this meaning, fault-locating devices become part of preventive maintenance.



nance and become, in fact, fault-anticipation devices. The third item mentioned by McGuigan is, of course, unitization of equipment.

Marginal testing, so usefully employed in the large electronic computers, is a powerful form of fault prediction, and should be employed wherever possible. These several techniques are described below.

So important are these techniques that a proposed modification to MIL-E-4158 states "Built-in test equipment shall be incorporated to the fullest practicable extent to permit monitoring of performance on a 'go-no-go' basis. Techniques shall be included for assessment of overall performance of the entire equipment. The built-in test equipment shall enable rapid assessment of performance by unskilled personnel. Marginal checking techniques providing information regarding anticipated failures shall be incorporated to the fullest extent possible."

Value of Fault-Locating Techniques. In a maintenance-minimization study conducted by Stanford Research Institute for the Office of Naval Research, much effort was taken to install in a unitized radar monitoring and fault-locating circuits, apparatus, and instruments, so that the maintenance personnel would have constantly at hand the required devices. One of the simplest techniques to be found in many electronic equipments is inclusion in power circuits of a low resistance, the voltage across which will be a measure of the current flowing in the circuit. A voltmeter with part of the scale marked off in areas to show satisfactory and unsatisfactory operation, and installed so that it can be switched to various portions of the equipment, forms a simple but very useful adjunct. Other circuit features that enabled the maintenance personnel to locate faults quickly are described in the Final Report. /2/

During this program a unitized radar was constructed, so that it had the same functional abilities as a commonly-used shipboard radar. Maintenance crews were instructed in procedures for the conventional equipment and for the experimental setup.

It is worth noting that two benefits were obtained by the unitized equipment in which had been incorporated the numerous fault-locating devices. There was a saving of 33 percent in the performance-recognition time, compared to the conventionally packaged radar, and a saving reduction of 64 percent in fault-location time. Second, the maximum range of time required for the members of the crew to recognize a fault dropped from 105 minutes to 27 minutes, and dropped from 137 minutes to 48 minutes to correct the fault.

The ability of the maintenance personnel to localize the trouble quickly because of the unitized construction and because of the built-in testing devices was clearly demonstrated. Future designs will undoubtedly reflect these findings.

Failure Prediction. Muncy defines this subject as "a measurement of the quality of electronic parts, made with sufficient precision, and at the properly spaced periods so as to insure as nearly as possible that failure is not imminent. The measurement must be made without adversely affecting the part and, in some cases, while the equipment is operating normally." /3/ Much of what follows is taken from his paper.

Simple tests of current, voltage, or the effects of increments of these quantities on circuit performance have been employed for a long time. They require voltage or current jacks into which a meter may be plugged, or an intricate switching system, so that few meters may be made to do much work. The insertion of a small resistor in current-carrying leads, especially if one end of the resistor can be at ground potential, is very effective, since current may now be measured in terms of voltage by an instrument less likely to be damaged by malfunctioning. These checks allow a slow, otherwise unobserved deterioration to be watched and not allowed to proceed far enough to be detrimental to the equipment and its operation.

For large multitube systems, more sophisticated techniques have been developed. The digital computer designers have led in these developments because a single fault, lasting for only a few microseconds, can invalidate many hours of computing time. The approach usually has been to employ one section of the computer to detect out-of-limit performance in another section upon which a shift has been imposed. Large economies in switching and metering can result in the coordination of suitable diagnostic routines and simple variations in supply voltages.

The 2-mc flip-flop circuit presented in the chapter on Electrical and Electronic Factors was designed as part of the computer testing system of Whirlwind II.

A technique to test tube quality in situ is to inject a test signal as shown in Figure 12-1. High accuracy can be achieved because the check is made at normal electrode potentials. Automatic switching and measuring will speed up this kind of test to a very great extent.

Crystal diode condition, forward and backward resistance, have been measured by the effect on stage performance when a bias or gating voltage is shifted. This is illustrated at points 1 and 2, Figure 12-2.

It is well to note that when checking the quality of a part by stage performance, it is necessary to measure both an upper and lower limit, since the deterioration may be of such nature as to cause an increase in performance as well as a decrease in performance.

Marginal Testing. The theory of marginal

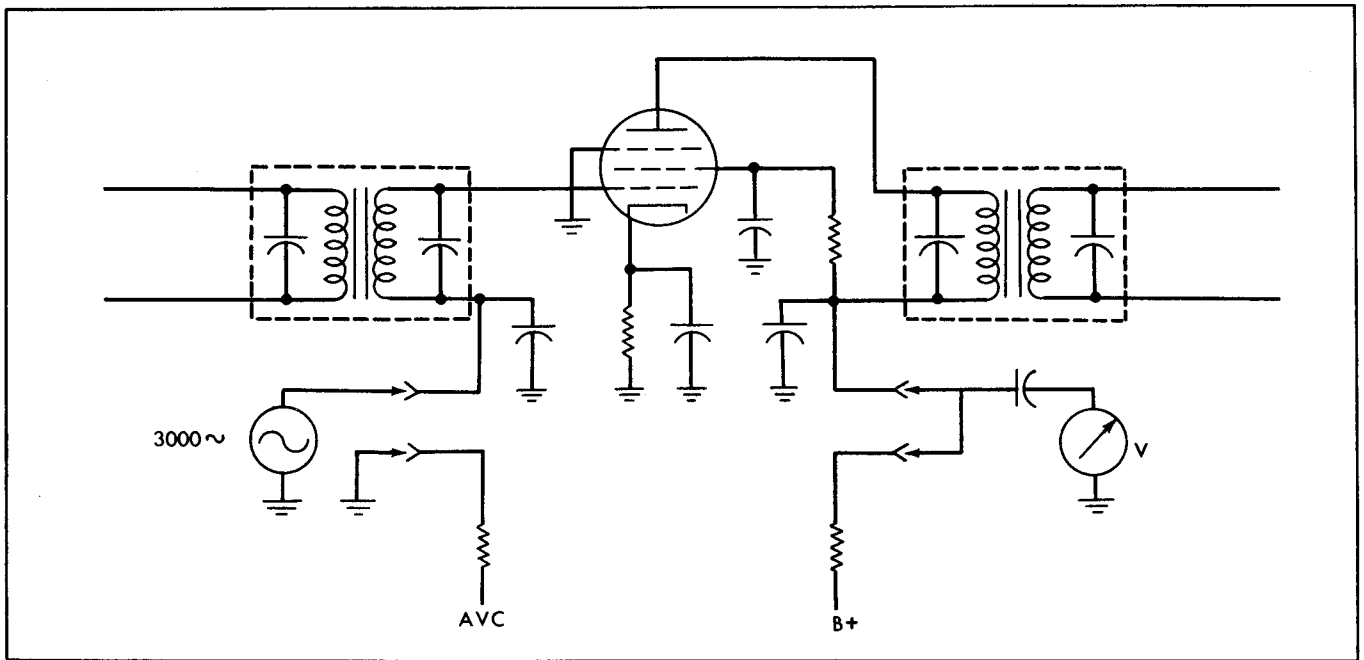

Figure 12-1. Method of testing tube quality in situ

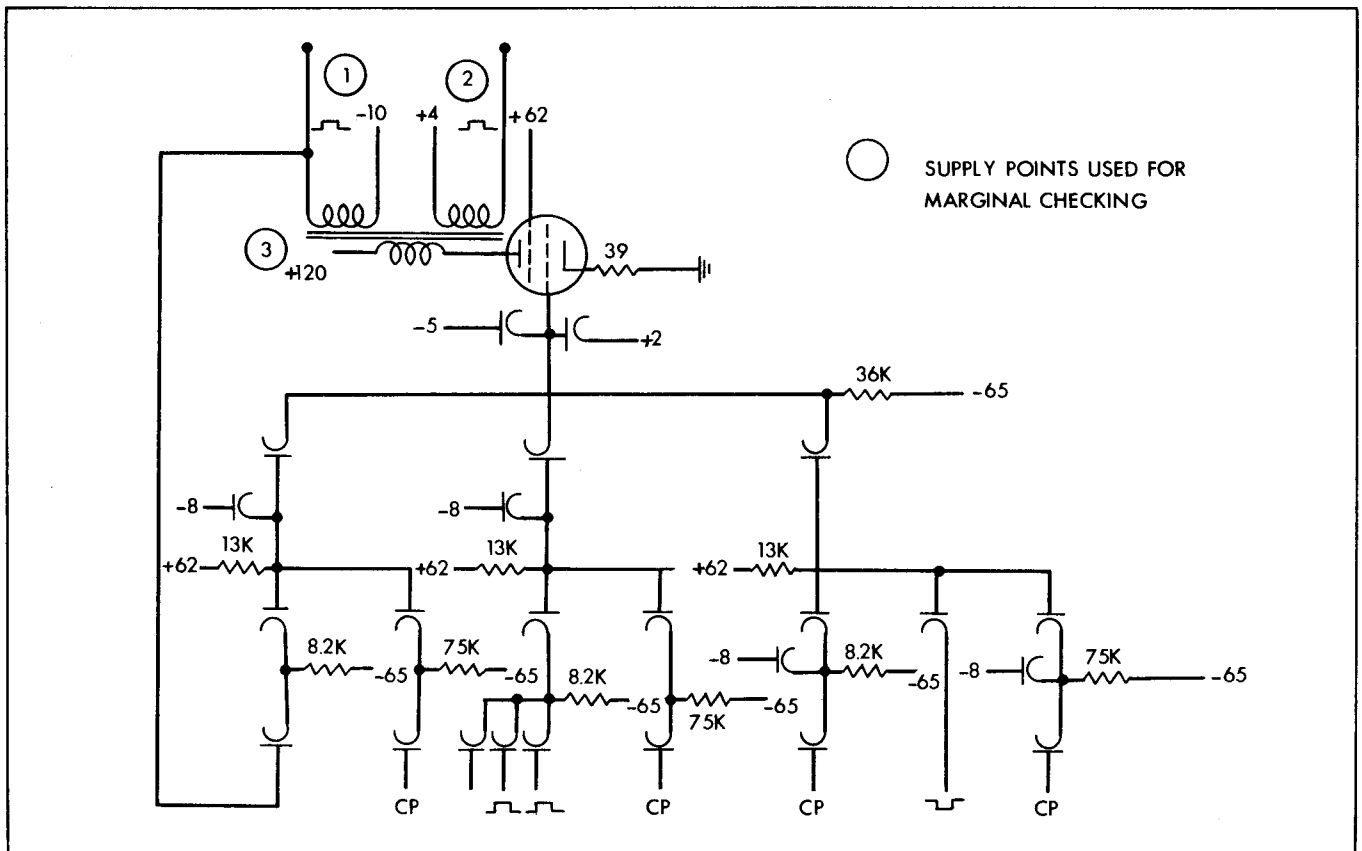

Figure 12-2. Method of checking crystal diode condition by shifting bias or gating voltages

testing is simple. All parts of complex circuits work best within certain defined limits, say of voltage, current, and so on. If this voltage or current is exceeded or decreased outside the working limits, something happens. If the voltages are decreased, the gain of an amplifier, as an example, goes too low to permit the circuit to function, because some part of the circuit will not function properly at this voltage. If the voltage, therefore, is lowered to the point where this part or component refuses to function properly, and this unit is located, it will be found that it is already on the way out; it is ready for failure, and will probably be the first unit or component to go bad under normal working voltages. The emission of tubes, for example, goes down if the heater voltage is reduced. A good tube will have a higher emission at a low voltage than one that is in imminent danger of being exhausted.

The marginal testing techniques must be engineered for the particular job they must fit; but the principles are common.

Marginal testing procedures, as developed at the Servomechanisms Laboratory of Massachusetts Institute of Technology for use in the Whirlwind computers, have been so thoroughly documented that the details need not be repeated here. The advantages of the systems developed are clear.

The experience of Remington-Rand with the ERA 1101 computer gives evidence of the value of marginal testing. During a 12-month period, computation time was interrupted by 37 tube failures out of 2,200 tubes being checked. Of these 37, only 11 were gradual failures that should have been detected. The total number of tubes removed was large, but the extra time that was available for machine operation was sufficient compensation. The time spent on marginal checking is about 10 percent, with 2 to 4 percent in unscheduled maintenance time.

Other results may be gleaned from the proceedings of the Eastern Computer Conference. /4/

Built-in Test Equipment. Whether or not the test equipment is to be built-in depends entirely upon the particular situation and the requirements. If speed is essential in getting equipment back on the air, if the system has a high rate of failure, or if continuous monitoring is necessary, then the virtues of built-in test equipment outweigh the possible disadvantages of greater weight, size, and complexity. It must be remembered that the test equipment itself is subject to failure and deterioration. Some part, at least, of the fault locating system must be permanently designed into the equipment, so that the attachment of this test equipment will be facilitated when needed. The final report of the Stanford Research Institute study on maintenance minimization covers the various aspects of the problem rather thoroughly. Only experience will finally demonstrate the full advantages and disadvantages of unitized systems with built-in test equipment. That experience has not as yet been fully accumulated or documented.

## HUMAN ENGINEERING ASPECTS

Aside from the purely technical considerations of the test equipment, that is, its accuracy and sensitivity, the fact that it must be used by maintenance personnel, often under stress, must not be overlooked. The examination made by the American Institute for Research /5/ indicates that much remains to be learned about the human engineering problems. Some of the following material is from the final report of this study.

Design Considerations. The purpose of test equipment is to take information out of the operational equipment and present it in such a form to the technician that he can make the necessary decision or job action. It is a task for systems or operational analysis to determine what information essential to his duties must be taken from the operating equipment and presented to the technician. This analysis can best be performed by the engineer, provided it is clear in his mind precisely what decisions and job actions will be required of the technician. He will be almost as much concerned with not giving the technician more information than he needs as he will be concerned with providing him with sufficient information.

The principal functions of test equipment may easily be enumerated. First, it must pick up the suitable signal to be tested from the operating equipment. Secondly, it must decode that signal and, thirdly, it must display the decoded signal so as to permit the technician to make the discrimination necessary to his particular job requirement.

A single-purpose test set requires a minimum of discriminations, decisions, and control actions. Hence, it will produce a minimum of human error and will require minimum time to use. If, however, it is a multipurpose tester, there will be selector controls and matching displays which will have to be chosen and manipulated by the technicians. These manipulations will have to result in display changes, so that the technician can readily tell what the test set is prepared to do to the signal. This information may have to guide the technician in understanding the signal display, and perhaps a dial that contains several scales as well.

The display of the signal that the test set has taken from the operational equipment will have to be identified, read, and interpreted by the technician in the light of his job requirement. This requirement may be to determine if a given check point is yielding a signal that is in or out of tolerance, and how much out of tolerance, and in which direction. Whether the display may not or may inform him directly that a given component must be replaced, it may provide the technician with information that helps him to solve a trouble-shooting problem; his decision as to which next effective step to take is thereby aided. Field reports indicate that some current test equipment presents difficulties in interpretation. It is important to determine what makes for ease or difficulty in

interpretation of displays. This problem is not independent of the critical information required by the technician to perform his job.

But the test set, assuming it is not integral to the operating equipment, has a number of secondary functions. It must be transportable from place of storage to a place of use. Size, weight, shape, and identifiability become characteristics related to the abilities of, and ease of use by, the technician.

The technician may have to attach the leads from test set to equipment, identify and manipulate selector knobs on the test set and, possibly, the equipment, take a reading from the test set, and often to perform all these activities from one physical position. If he must do all this while he holds the test set, he may be posed a practically impossible task, which demands three or more hands. He cannot put the test set down because he has to be close enough to the display dial to read it. Task requirements may dictate mechanical methods of readily attaching the test set to a support, such as fasteners on the equipment itself, which facilitate, or at least make possible, a single technician to use a test set. Complaints about heavy or bulky test sets, and praise of easy-to-carry test equipment, testify to the importance of size and weight. If the test set is used in conjunction with job instructions, such as technical orders, the technician need make a minimum interpretation between display readings and job instructions.

A long body of information is becoming available about good vs. poor practices in panel design, but it is not yet known if it is better to design a panel in which displays and controls are better grouped by function, such as test setups vs. test measurements, or by some other, more arbitrary method. We need to know from the technician's standpoint what is the simplest way of shifting from one test surface to another on the same set. Thus, is it better to have only one set of cords or jacks with multiselector knobs, or to have various sets of jacks and cords with no selector knobs? When we talk of simplicity we mean speed, freedom from error, and lack of physical effort, or a minimum of mental steps. The desires for simplicity and versatility are antagonistic, and can be reconciled only through design principles that take into account the peculiar job requirements of maintenance. If the test equipment is built into the prime equipment, problems arise as to the best location for test display. These locations may affect the operator, who may be confused by additional dials and the needs of the technician. For example, there may be good reason to bring all test displays into a single monitoring unit of the equipment panel. Not only may engineering problems be created by such an organization, but difficulties for the technician, such as wire tracing, may be increased out of proportion to the assets gained by the central location of test displays.

Because so much time, effort, and operational dependability hinge upon the accuracy of the test equipment decoding and uncoding functions, it also is

necessary to consider simple ways of testing the accuracy of its readings. How frequently it should be checked can be estimated only by engineering tests of the reliability of given test equipment, plus an estimate of the operational importance of test set failures when these failures occur but are not recognized.

Familiarity as a Time Saver. From the human engineering point of view, there are numerous unspectacular techniques that may be employed to make the maintenance technician's job easier and faster. One is to use layouts for apparatus in which associated parts appear together. A confused technician is working with a handicap. Power supply parts should be grouped so that the parts the technician naturally associates with power supplies can be readily located. If the transformer, for example, is hidden in some other part of the equipment, temporary confusion may result. This is a job for the packaging engineer.

Panel layouts can also make servicing easier. The sequence of controls can be made fairly obvious by the location of switches or controls with respect to each other. Considerable use is being made in the industrial control field of "phantom" schematics impressed on the front panel of the control equipment, the schematic showing the normal flow of power, and so on. This element of familiarity is one of the strong arguments in favor of "preferred" circuits; having become familiar with one limiter, or detector, or regulated power supply, the maintenance technician is immediately able to service a similar unit from another piece of equipment. On the other hand, if the limiter, detector, or power supply in the second equipment has a different circuit, more or fewer components, or other differences — even though the functioning may be exactly the same — this element of familiarity does not exist. The technician must now become familiar with two limiters, for example, instead of one "standard unit."

Consistent color-coding of wiring, standardized when possible, is a very valuable technique. /5/

The designer, in considering the maintenance technician when he chooses the circuit, when he lays out the parts, when he sets the tolerances of circuit function, or determines test procedures, can make that technician's job quick, easy, or complex.

Accessibility. The fundamental rule that accessibility of the components should bear a direct relation to their known propensity for failure is often expressed in the literature. But following this rule is not enough.

In some home television receivers it is virtually impossible to remove the tubes without a special tool, or to get at some of the tubes without taking the whole chassis out of the cabinet, or to replace one component without unsoldering several others. This is bad practice where time is of great importance, as is

true with military equipment.

If it is physically difficult to localize trouble, in a detector for example, the technician will try the other, more accessible circuits first, on the off chance that the difficulty here and not in the detector! This seems to be human nature.

If a combination of strength and dexterity is necessary to perform a certain maintenance function, there is always a good chance that something in the equipment is going to be damaged in the process. Strong-arm tactics and precision of movement do not often go together.

A concomitant to the accessibility problem is that of working space and facilities. If three parts have to be removed to replace one, some place must be provided to put the two parts while they are out of the equipment. These extra parts have a good chance to be lost or broken. Time taken to locate a misplaced screw is just as valuable as time taken to balance a servo unit.

It is probable that designers will continue to lay out new equipment and that manufacturers will continue to package that equipment according to precedent. These are the ways things are done. Only imagination can disclose new, and perhaps better, ways; and only operational research or the experimental approach of "human engineering" can disclose the necessity of new methods and their value after they have been invented. But it is unreasonable to believe that engineers cannot devise better layouts or packaging techniques.

Complaints on Poor Accessibility. In a study on radar systems and their operation conducted by the American Institute for Research, the following complaints were developed by maintenance and operating personnel. Although these particular complaints applied specifically to tube inaccessibility, a little generalization will make them apply to all other component parts of equipment.

1. Necessity for removing a large number of screws, fasteners, cover plates, and so on, to get at the affected tubes.
2. Difficulty of removing tube shields or clamps before removing the tubes themselves.
3. Necessity for removing other component parts before the tube can be removed.
4. Space surrounding tube too restricted to permit hand or tube puller to grab tubes easily.
5. Excessive amount of force required to remove tube from socket.
6. Interference with removal of tubes from

sockets due to proximity of other parts.

7. Proximity of tube to hazardous elements, such as moving parts, dangerous voltages, hot tubes, and the like.
8. Poor visibility.
9. Restricted, awkward, or uncomfortable body movement required to extricate tube from socket.
10. Physical shape of tube does not permit firm grasp by hand or tool.
11. Interference with removal of tube from component due to small size of access hole, aperture, or other opening.

General Considerations. One conclusion drawn by Muncy /3/ in his survey of failure prediction techniques is that no one technique can be universally adopted – not even for all digital computers. Accurate location of failing parts cannot be achieved by ordering new pieces of test equipment and incorporating them into the production model. Rather, the designer, in his very first thinking, must plan to devise measuring techniques where required, and to integrate them into the operational equipment. Several existing military electronic designs have been examined, very briefly, to see where it would have been advantageous and possible to include a form of incipient error detection. One case is worthy of full discussion. This equipment is an airborne navigational equipment for homing to carriers or land bases – a function of utmost importance. The designer knew that it had been necessary to underdesign certain stages just to get the functions in the aircraft. The maintenance section of the handbook begins with the caution that the replacement of defective tubes will be the most usual maintenance. A portion of this section is quoted:

"The first tube in the equipment which is likely to become defective is the 2C39A in the transmitter. As soon as signs of low emission become apparent, this tube should be replaced. The transmitter should be investigated if its output, as measured at the RF jack on the front panel, drops below 1 kw of peak pulse power."

"Next, follows a long paragraph on how to measure power output by unusual laboratory techniques and requiring 350 pounds of test equipment. The maintenance technician is then faced with removing the equipment from the aircraft and proceeding through to a lengthy test group routing just to check the condition of one tube. And, further, it is recommended that this test be performed after each thirty hours of flight time.

"Similarly elaborate tests are specified to measure receiver sensitivity at the same period. It is not meant to suggest that a built-in check of cathode condition would give all the information that power

output and sensitivity measurements give, but considering the stability of tuned circuits, these involved tests could be made much less frequently."

The job of the technician should be made

simple, if possible, but surely easy, logical, sensible, and accurate. An interesting and useful approach to the general philosophy of maintenance problems will be found in the special report of the American Institute for Research "Trouble-Shooting in Electronics Equipment: A Proposed Method." /6/

#### REFERENCES

1. McGuigan, William D., "Maintenance Minimization in Large Electronic Systems," Symposium on Reliability of Military Electronic Equipment, Institute of Radio Engineers (IRE), New York, March 6, 1952.
2. Maintenance Minimization in Large Electronic Systems, Final Report, January 15, 1952, Contract No. N7onr-32103, Stanford Research Institute, Stanford, Calif. (Confidential).
3. Muncy, J. H., "A Survey of Electronic Failure Prediction Technique," IRE National Convention, 1954.
4. Proceedings of the Eastern Joint Computer Conference, Joint IRE, AIEE, ACM Computer Committee, Washington, D. C., December 8, 9, and 10, 1953.
5. Survey of Human Engineering Needs in Maintenance of Ground Electronic Equipment, American Institute for Research, Contract No. AF 30(602)-24, February 1954.
6. Part of the project "A Study of Methods for Determining Skill, Knowledge, and Ability Requirements for Maintenance of Newly Developed Equipment," March 1953. Several reports have been issued under Air Force Contract No. AF 33(038)-12921, including "Recommendations on Designing Electronics Equipment for the Job of Maintenance," June 1951; "The Validity of Maintenance Job Analysis from the Prototype of an Electronic Equipment, Part I: AN/APQ-24, June 1952; Part II: K-1 Bombing-Navigation System, February 1953."

# Index

## A

Acuity, 7-5  
Ad Hoc Group, 1-1  
Advisory Group, Electron Tubes, 1-2  
AGC circuits, 9-13  
AGET, 1-2  
AGREE, 1-5  
Air cooling, 6-4  
Altitude effects on tube operation, 8-22  
Amplifier design, a-f, 5-8  
Antenna separation, 9-4  
Arc suppression, 8-56  
Arc-over, gap versus voltage breakdown, table, 6-10  
ARINC study, 1-3; 8-4  
Audio-frequency voltage amplifier design, 5-8  
Audition, 7-6  
Automatic production techniques, 10-1  
Auto-sembly, 10-4

## B

Bell Laboratories reliability program, 1-4; 8-1  
Binaural hearing, 7-7  
Binocular and Monocular vision, 7-4  
Biological growth effects, 6-24  
Body measurements, tables, 7-10  
Breathing of components, 6-23  
Built-in test equipment, 12-2; 12-4  
Bypassing and filtering, 9-3

## C

Capacitance, distributed, r-f coils, 8-53  
Capacitors, 8-46  
    button-mica, 8-48  
    ceramic, 8-47  
    silver migration, 8-49  
    specifications, 8-50

Capital investment, electronics, 1-1  
Catastrophic failures, 1-7  
Cathode follower, infinite impedance, 5-8  
Circuit, design check list, 8-34  
    fundamentals, 5-1  
    Naval Electronics Laboratory, 5-8  
    preferred, 5-7  
    reliability, 5-2  
Color, coding, 7-27  
    perception, 7-5  
    psychology, 7-6  
    usage, 7-30  
Common-impedance troubles, 9-11  
Complexity vs. reliability, 1-2; 1-8  
    maintenance, 2-3  
    simplicity, 2-2  
Components, application, 2-2  
    breathing, 6-23  
    causes of failures, 8-1  
    embedment, 6-12  
    miniaturized, 6-10  
    Rand study data, 8-2  
    stability, 5-2  
    special vs. standard, 10-6  
Computer reliability, 12-2  
Condensation effects, 6-23  
Connectors, 8-50  
Contact potential, 5-20; 8-24  
Controls, 7-24  
Cornell University program, 1-3  
Corona-discharge test setup, 8-52  
Crank dimensions, 7-26  
Crystal diode testing, 12-2  
Crystal, quartz, types, table, 5-13

## D

Definitions of reliability, 1-6  
Depth perception, 7-5  
Dielectrics, liquid, table, 6-23

Dip soldering, 10-4  
Displays, combined, 7-21  
    pictorial, 7-18  
    visual, 7-16  
Dual-tube balance, 8-16  
Dust and sand effects, 6-28

## E

Edge lighting, 7-23  
Electrical hazards, 5-27  
Electrolytic corrosion, 6-28  
Embedment, 6-12  
    compounds, table, 6-16  
Encapsulation, 6-12  
Environmental factors affecting reliability, 6-1  
Equipment publications, 11-1  
Exponential failure, 1-7  
Exponential law of reliability, 4-9

## F

Fail-safe circuits, 5-28  
Failure, due to wear out, 4-10  
    prediction, 12-2  
    rate, 1-6; 4-5  
        nuclear instruments, 8-2  
Fasteners, 6-32  
Fault-locating techniques, 12-2  
Feedback, advantages, 5-24  
    stabilization, 8-33  
Field experience, importance, 2-5  
Filters, harmonic suppression, 9-5  
    interference prevention, 9-3  
        power-line 9-5; 9-11  
        transmitter output, 9-3  
Fixed resistors, 8-37  
Flip-flop design, 5-4  
Floating grid techniques, 8-26  
Fluid filling, components, 6-21  
Force exertable by human body, 7-8  
Fungus effects, 6-24

## G

Gas-filling versus embedment, 6-20  
Gaussian law, 4-10  
Glare, 7-6; 7-29  
Grid circuit leakage, 8-26  
Grid emission problems, 5-20; 8-28  
Grounding techniques, 5-23; 9-6

## H

Hand grasp measurements, 7-14  
Handwheel dimensions, 7-26

Harmonic-suppression filters, 9-5  
Heat, dissipation techniques, 6-4  
    insulation, 6-4  
    removal techniques, 6-4  
    (see also Temperature)  
    sinks, 6-3  
    transfer, 6-2  
Heater-to-cathode leakage, 8-14  
Hermetic sealing, 6-15  
Human engineering, 7-1  
    application of principles, 7-15  
    definition, 7-2  
    maintenance applications, 7-27  
    problems, how to handle, 7-3  
    terminology, 7-2

## I

Illumination, 7-6  
    artificial lighting, 7-29  
    edge lighting, 7-23  
    external, 7-23  
    panels, 7-23  
    visual indicators, 7-23  
In-commission rate, 1-7  
Indicators, pictorial, 7-20  
    visual, 7-18  
Inductors, 8-52  
    distributed capacitance, 8-53  
Industrial electronics experience, 1-10  
Interelectrode insulation, 8-14  
Interface effects in tubes, 8-30  
Interface impedance, 8-14  
Interference, at receiver, 9-7  
    man-made noise, 9-10  
    prevention, 9-1  
Interlocks, 5-27  
Interphone communication, 7-24  
Instrument panel layout, 7-15; 7-19

## J

Jamming, 9-12  
JETEC, 1-5; 8-6

## K

Knob shapes, 7-25

## L

Lead-time to produce new components, 2-8  
Light reflection, table, 7-32  
Light sensitivity of the eye, 7-4  
Limiters, 9-8  
Low temperature effects, 6-6



Lowest bidder practice, 2-1; 2-5  
Loudness discrimination, 7-7  
Luminous paint usage, 7-24

## M

Maintenance, accessibility importance, 12-5  
  aspects of reliability, 2-8  
  human-engineering aspects, 12-4  
  manuals, errors, 12-6  
  preparation, 11-1  
  rate, 1-6  
  techniques, 12-1  
Man-made noise, 9-10  
Manuals, maintenance, errors, 12-6  
  preparation, 11-1  
  specifications, 11-3  
Marginal testing, 5-24; 12-2  
Mechanical factors affecting reliability, 6-1  
Mechanized assembly, 10-1  
Metal surface protection, 6-27  
Miniaturization, 6-8; 10-7  
  components available, 6-10  
Mission success rate, 1-7  
Moisture effects, 6-22  
Monocular and binocular vision, 7-4  
Monostable multivibrator design, 5-3  
Motion economy, 7-10  
Motor performance, 7-8  
Movement perception, 7-6  
Movement precision, 7-9  
Movement speed, 7-9  
Multivibrator design, 5-3

## N

Noise, effect on performance, 7-7  
  problems, 7-32

## O

Old-age troubles, 1-7  
Oscillator, Clapp, 5-9  
  design, 5-8  
  quartz crystal, design, 5-12  
  stability rules 5-10

## P

Panel, design problems, 12-5  
  illumination, 7-23  
  layout principles, 7-15  
Panel on Electron Tubes, (PET), 1-3  
Perception, 7-5  
Personnel hazards, 5-27

Phase cancellers, 9-10  
Pilot lights, 7-21  
Pointer dimensions and types, 7-19  
Power-line filters, 9-5; 9-11  
Probability, concepts and relations, 4-4  
  joint, of independent events, 4-6  
Procurement considerations, 2-5  
Proprioception, 7-7

## R

Rand study data, 8-2  
Reaction time, 7-9  
Receiver design hints, 9-10  
Rectifier circuit reliability, 5-19, 20  
Redundancy considerations, 5-26  
R-F coils, 8-52  
Relay problems, 8-55  
Reliability, as function of complexity, table, 2-4  
  as a function of time, 4-3  
  average success rate, 4-3  
  background 1-1  
  contract clauses, 2-6  
  data sources, 4-12  
  definitions, 1-6  
  environmental factors, 6-1  
  exponential law, 4-9  
  lack of, causes, 2-1 -- 2-9  
  mathematical approach, 4-1  
  mechanical factors, 6-1  
  miniaturization problems, 6-8  
  moisture effects, 6-22  
  operation and maintenance aspects, 2-8  
  parallel, 4-8  
  quantitative definitions, 4-2  
  salt-spray effects, 6-27  
  statistical approach, 4-2  
  statistics, WWI, 1-1  
  theory, qualitative usage, 4-13  
  vs complexity, 1-2; 1-8  
Resins for embedment, 6-13  
Resistors, composition, 8-37  
  fixed 8-39  
  glass-type, 8-39  
  hysteresis, 2-2  
  misapplications, 8-43  
  noise characteristics, 8-38  
  specifications, 8-45  
  wire-wound, 8-40  
RETMA, 1-4

## S

Salt spray effects, 6-27  
Sand and dust effects, 6-28  
Sargrove automatic production machine, 10-1  
Scale indices, 7-19  
Scale marking, 7-19  
Scales and dials, 7-18  
Seating and work space principles, 7-28  
Service instruction manuals, 11-2

Servomotors, 8-29; 8-60  
Shielding, 9-2  
    effect on r-f coils, 8-54  
Shock and vibration, 6-28 (see also Vibration)  
    mountings, 6-29  
    test results, 6-31  
Silver migration, 8-49  
Skin sensitivity, 7-7  
Snow load, 6-7  
Soldering techniques, connectors, 8-51  
Sound intensity effects, 7-6  
Specifications, effects of poor, 2-7  
    MIL, as information sources, 8-5  
    military, 2-7  
    realistic, 2-6  
    tube, 8-6  
Stability, heater-voltage, 5-25  
    oscillator, 5-10  
    quartz crystal, 5-16  
Stabilization by screen dropping resistor, 8-35  
Starvation circuits, 5-21  
Statistical methods, 8-36  
    limitations, 4-1  
Storage problems, 6-32

## T

Temperature, and ventilation, 7-33  
    high, effects 6-2  
    low, effects, 6-6  
    (see also, Heat )  
Tinkertoy, 10-3  
Transformers, 8-52  
Transistors, 6-11, 8-37  
    multivibrator, 6-13  
Transportation problems, 6-32  
Tremor, 7-9  
Trick circuits, 5-2  
Tubes, accelerated life tests, 8-17  
    altitude effects, 8-22  
    application techniques, 8-9  
    characteristics distribution, 8-8  
    contact-potential troubles, 8-24  
    floating-grid troubles, 8-26  
    gas-current troubles, 8-25  
    grid-current effects, 8-23  
    grid emission, 8-28  
    heater-cathode leakage, 8-27  
    improper usage, 8-22  
    interface effects, 8-30

    life-test considerations, 8-12  
    life vs. off-standard operation, 8-16  
    temperature, 8-17  
    manufacturing problems, 8-4  
    shock tests, 8-21  
    specifications, MIL, 8-6  
    temperature-reduction techniques, 8-18  
    transconductance changes, 8-14  
    UHF, 8-31  
    vibration noise, 8-20

## U

Universality, pro and con, 2-3  
Unreliability, causes, 2-1 -- 2-9  
Unsatisfactory Reports (UR), 4-12

## V

Vacuum Tube Development Committee, (VTDC) 1-33  
Vibration, and shock, 6-28  
    effects of performance, 7-8  
    mountings, 6-29  
    test results, 6-31  
Vibrator selection and usage, 8-56  
Visibility of point sources, 7-5  
Vision, 7-4  
Visual displays, 7-16  
Visual indicators, 7-18  
    illumination, 7-23  
Vitro study, 1-4, 8-1  
Voltage divider design, 5-3; 5-8  
Voltage regulator design, 5-24

## W

Waterproof seals, 6-20  
Wave traps, 9-8  
Windchill, 6-6  
Wire-wound resistors, 8-40  
Work area layouts, 7-31  
Work, illumination principles, 7-28  
    space and seating principles, 7-28