

5900

DIGITAL MULTIMETER

RACAL-DANA Instruments Inc.

18912 VON KARMAN AVENUE, P.O. BOX C-19541, IRVINE, CALIFORNIA 92713
TELEPHONE: (714) 833-1234; TELETYPE: 910-595-1136; TELEX: 678-341

PUBLICATION DATE: JULY 1978

WARRANTY

Within one year of purchase, Racal-Dana will repair or replace your instrument, at our option, if in any way it is defective in material or workmanship. All parts and labor charges will be paid by Racal-Dana Instruments, Inc. Just call Racal-Dana Product Service at (714) 833-1234 collect in California, for assistance. We will advise the proper shipping address for your prepaid shipment. Your instrument will be returned to you freight prepaid.

PROPRIETARY NOTICE

This document and the technical data herein disclosed, are proprietary to Racal-Dana Instruments, Inc., and shall not, without express written permission of Racal-Dana Instruments, Inc., be used, in whole or in part to solicit quotations from a competitive source or used for manufacture by anyone other than Racal-Dana Instruments, Inc. The information herein has been developed at private expense, and may only be used for operation and maintenance reference purposes or for purposes of engineering evaluation and incorporation into technical specifications and other documents which specify procurement of products from Racal-Dana Instruments, Inc.

FOR YOUR SAFETY

Before undertaking any maintenance procedure, whether it be a specific troubleshooting or maintenance procedure described herein or an exploratory procedure aimed at determining whether there has been a malfunction, read the applicable section of this manual and note carefully the WARNING and CAUTION notices contained therein.

The equipment described in this manual contains voltages hazardous to human life and safety and which is capable of inflicting personal injury. The cautionary and warning notes are included in this manual to alert operator and maintenance personnel to the electrical hazards and thus prevent personal injury and damage to equipment.

If this instrument is to be powered from the AC Mains through an autotransformer (such as a Variac or equivalent) ensure that the instrument common connector is connected to the ground (earth) connection of the power mains.

Before operating the unit ensure that the protective conductor (green wire) is connected to the ground (earth) protective conductor of the power outlet. Do not defeat the protective feature of the third protective conductor in the power cord by using a two conductor extension cord or a three-prong/two-prong adapter.

Maintenance and calibration procedures contained in this manual sometimes call for operation of the unit with power applied and protective covers removed. Read the procedures carefully and heed Warnings to avoid "live" circuit points to ensure your personal safety.

Before operating this instrument.

1. Ensure that the instrument is configured to operate on the voltage available at the power source. See Installation section.
2. Ensure that the proper fuse is in place in the instrument for the power source on which the instrument is to be operated.
3. Ensure that all other devices connected to or in proximity to this instrument are properly grounded or connected to the protective third-wire earth ground.

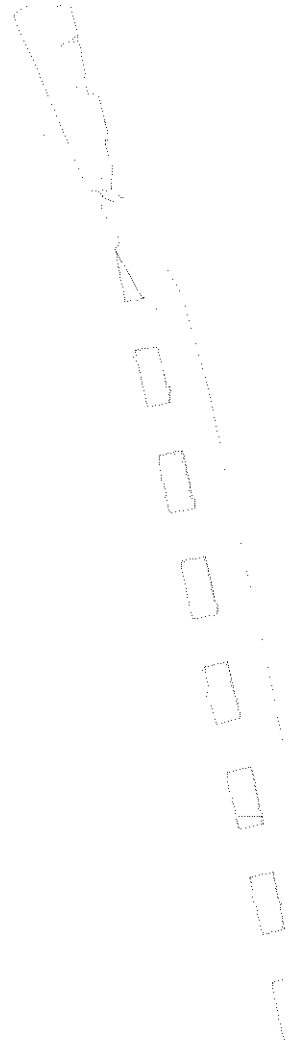
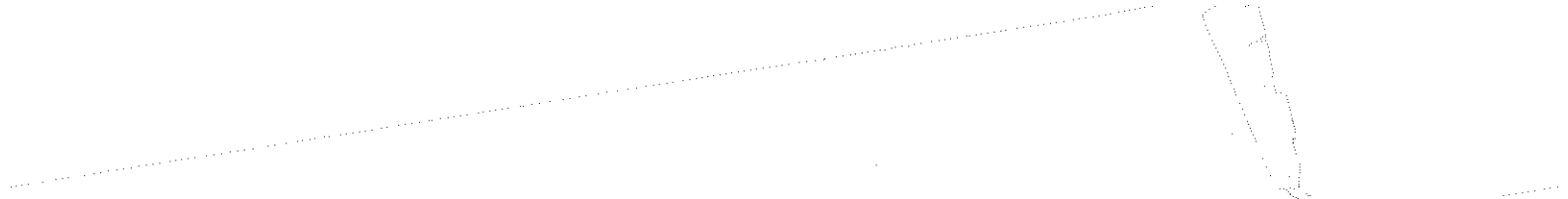

SECTION 1

GENERAL DESCRIPTION

1.1 INTRODUCTION.

1.2 The Model 5900 Digital Multimeter is a five-decade instrument with a sixth digit providing 60% overrange. The basic instrument is equipped for dc and dc/dc ratio measurements on five ranges. With the addition of the optional AC Converter, a-c and ac/dc ratio measurements on four ranges are available. The Ohms Converter, also optional, adds ohms measurements on eight ranges. Complete measurement capability of a fully equipped instrument is tabulated in table 1.1.

Table 1.1 - Measurement Capability

Range	FUNCTION		
	DC & DC/DC RATIO (Basic 5900)	Ohms (Model 52 Ohms Converter)	AC & AC/DC RATIO (Model 32 or 33 AC Converter)
.1V	X		
1V	X		X
10V	X		X
100V	X		X
1000V	X		X
10 Ω		X	
.1 K Ω		X	
1 K Ω		X	
10 K Ω		X	
100 K Ω		X	
1000 K Ω		X	
10 M Ω		X	
100 M Ω		X	

1.3 Range can be selected manually or automatically (autorange). In AUTO range, the proper range for a particular measurement is selected automatically (full scale is defined as "100000" on any range). The instrument "up-ranges" at 160% of full scale and "downranges" at 15% of full scale. Polarity selection is also automatic and is displayed on the readout.

1.4 Two operating modes are provided. In Hold mode (RATE control on EXT), a measurement is held (displayed)

until a single reading is commanded by an external command. The new measurement is then held until the next external command. In Periodic mode (RATE control CW), measurements are made automatically at the rate of approximately four per second.

1.5 The basic Model 5900 includes an analog output voltage that is proportional to the parameter being measured (except ratio). The voltage, at 20 volts maximum, is available at a rear panel connector.

1.6 Also included as standard equipment is a solid-state isolated BCD output. TTL-compatible output levels of the reading, function, range, etc., plus a print command are provided. An additional line enables a new reading to be commanded externally. An optional isolated remote programming unit (Model 42) allows all operating commands to be made externally.

1.7 OPTIONS.

1.8 All optional accessories having model numbers are plug-in circuit boards that may be added at any time. A calibrated accessory board can be installed without affecting the d-c calibration of the basic instrument. An instrument shipped without PCB accessories will not be equipped with a Function Switching PCB assembly (Accessory Card, Option 12). This board must be added when accessory boards are installed. Analog accessories are identified in table 1.1.

1.9 Model 42 Remote Programming.

1.10 The Model 42 Remote Programming accessory allows the selection of function, range, filter, read command, etc., to be made externally. Auto range selection is also provided and appropriate timeouts are generated internally when ranging takes place. Remote Programming "overrides" all manual control settings to prevent erratic selections. Complete isolation of the programming unit is achieved by the use of photo-couplers and pulse transformers.

1.11 Rear Input Options (-1, -1B, -1S, -1SB).

1.12 Two rear input options are available for the Model 5900 DMM. The option designated -1 or -1B consists of connector J204 on the back panel with input lines \pm INPUT, \pm CURRENT, and GUARD wired in parallel with the front panel input terminals; the option designated -1S or -1SB is the same as the -1 or -1B except that the front or rear inputs are selectable by a switch on the front panel.

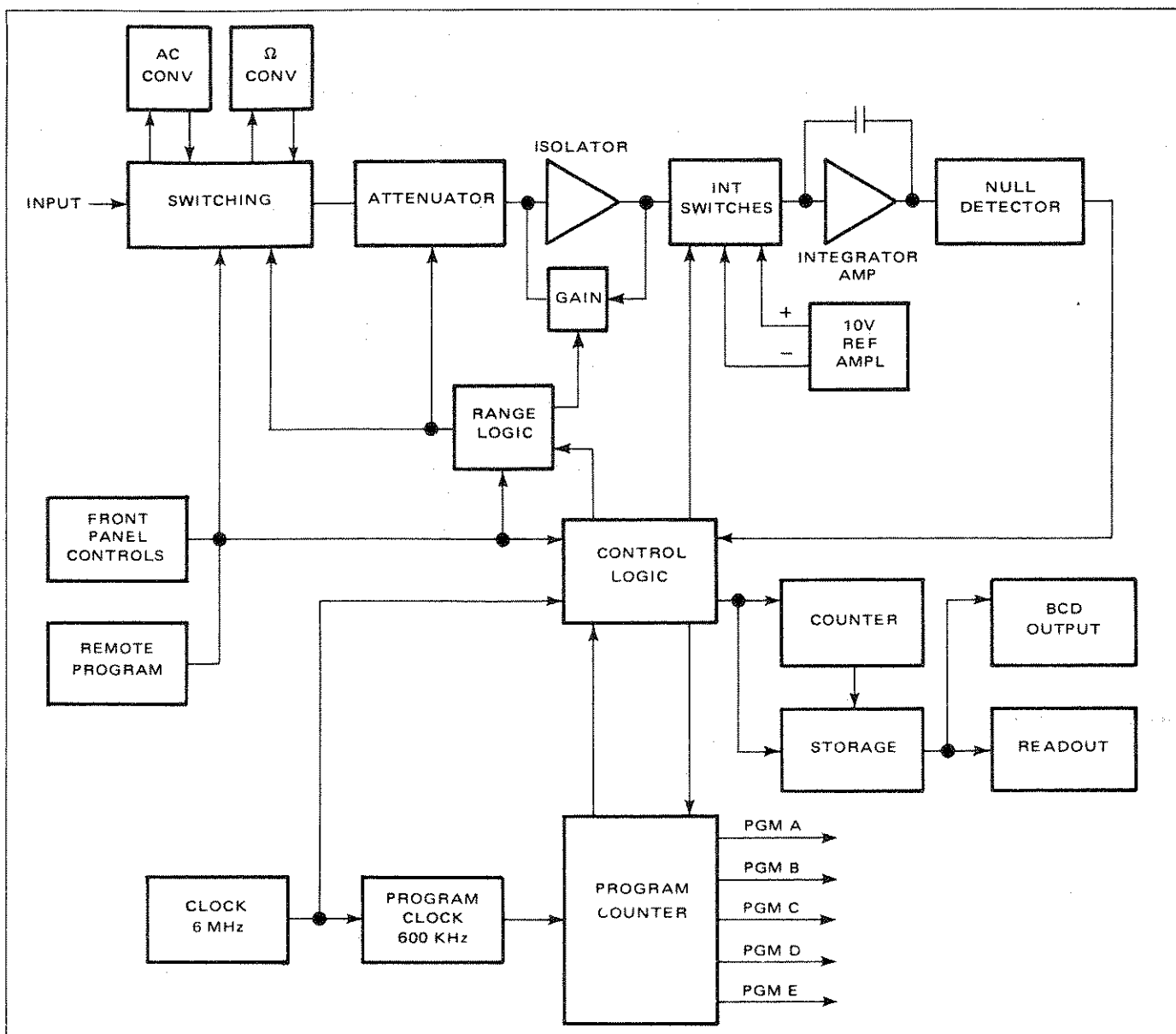

Figure 1.1 - Block Diagram - Model 5900

1.13 Rack-Mounting Flanges (403402).

1.14 Rack-Mounting Flanges are used where the instrument is to be installed in a relay-rack or cabinet.

1.15 High-Voltage Probe (641).

1.16 The High-Voltage Probe extends the voltage range of the instrument up to 10,000 volts (or 7500V rms). It is an insulated probe containing a 1000:1 voltage divider.

1.17 Current Shunt Set (651).

1.18 The Current Shunt Set consists of six precision shunt assemblies with values selected to produce a voltage drop that, measured in millivolts, has a numerical value equal to the current flow in milliamps or microamps.

1.19 MODEL 55 GENERAL PURPOSE INTERFACE BUS.

1.20 The Model 55 Microprocessing GPIB enables the Dana Series 5000 and 5900 Digital Multimeters or the Series 6900 Precision Voltmeters to be interfaced with other instrumentation and control devices utilizing the "standard interface bus" structure. The Model 55 Microprocessing GPIB is completely self-contained in a 1-3/4 inch high, rack mountable, piggyback package. It is compliant with IEEE Std. 488-1975, "IEEE Standard Digital Interface for Programmable Instrumentation." All connectors and cabling to connect the Model 55 with the 5900 are provided.

1.21 ELECTRICAL DESCRIPTION.

1.22 The Model 5900 DMM is a dual slope integration instrument consisting of three main functional areas: signal

conditioning, integrating, and control/display. A block diagram of the instrument is shown in figure 1.1.

1.23 The signal conditioning section includes the Switching p-c board, AC Converter, Ohms Converter, Attenuator, and Isolator. The function of these circuits is to convert the incoming signal to 10 VDC, full scale into the integrator.

1.24 The Integrating section consists of the Integrator amplifier, Null Detector and \pm reference voltages. The function of these circuits is to convert the conditioned input signal to an equivalent time period and to transmit this time period to the display portion of the DMM.

1 Dual slope integration operates as follows in a sequence of program (PGM) states:

- a. Signal Integration (PGM-A). The integrator capacitor charges to a voltage proportional to the input voltage during a $16\frac{2}{3}$ msec sampling period.
- b. Reference Integrate (PGM-C). During this period, the integrator capacitor discharges at a constant current. The time that the integrator requires to discharge (full discharge detected by the Null Detector) is measured by the counter. The data in the counter at the end of PGM-C is proportional to the input voltage.
- c. Strobe (PGM-D). At this time, data in the counter is strobed into the storage latches and displayed — the print pulse is inhibited, however if an uprange or downrange command is generated by the Auto-range logic. If a range change is required, the counter is reset and the program returns to PGM-A.
- d. Reset (PGM-E). At PGM-E, all internal logic is reset in preparation for the next reading.

1.26 An additional control state, PGM-B, occurs after PGM-A and is a delay to allow for propagation time of the counter.

1.27 The Control/Display section generates the control signals necessary to operate the signal conditioning and integrating circuits.

1.28 MECHANICAL DESCRIPTION.

1.29 The ohms measurement option consists of a single printed-circuit board. The AC options both consist of two boards. The accessory boards plus the Digitizer, Isolator, and Function Switching board all plug into the Main Logic board called the Logic and Interconnection assembly. This board also carries much of the instrument logic.

1.30 The Function Switching board is used only when either or both of the options (AC and Ohms) are installed. With no options installed, the Function Switching board is replaced with the Switching Bypass board. The Switching Bypass merely connects the + Input (from input connector) directly to the Isolator input and the - Input to ground.

1.31 At the rear edge of the Logic and Interconnection assembly is a PCB connector that extends to the rear panel and serves as the BCD output connector J201. If the optional Remote Program board is installed, it is mounted on stand-offs above the Logic and Interconnection board with the PROGRAM INPUT connector (J202) available at the rear panel above the BCD OUTPUT connector.

1.32 The POWER input connector J203, the power transformer, and power transistors for the power supply are mounted on the rear panel of the instrument. Other power supply components are mounted on the Logic and Interconnection assembly. Also mounted on the rear panel, in addition to J201 and J202, is the rear INPUT connector J204, the ANALOG OUTPUT connector and common, the EXTERNAL REFERENCE connector and common, and the line fuse F201.

1.33 A dimensional outline of the Model 5900 is shown in figure 1.2.

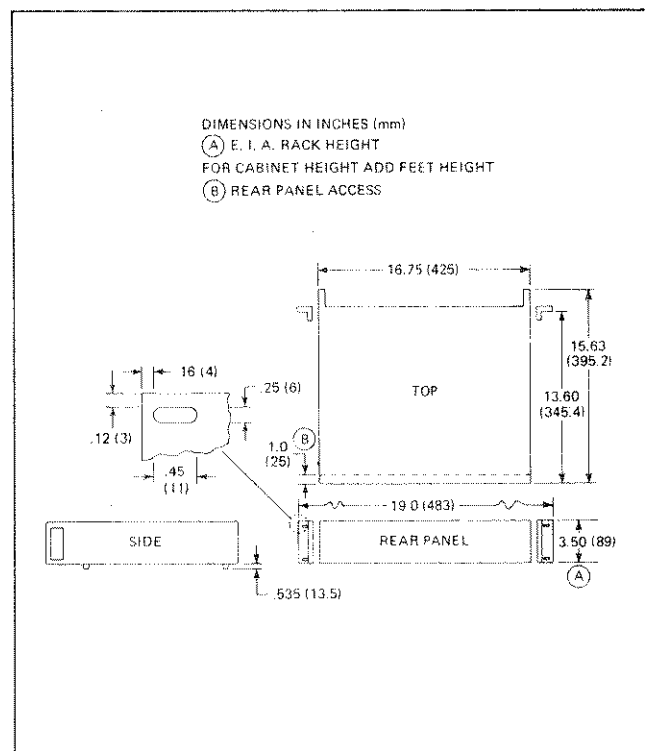

Figure 1.2 - Dimensions

1.34 SPECIFICATIONS.

1.35 Specifications are listed in table 1.2.

Table 1.2 - Specifications

GENERAL	
Conversion Technique:	Delayed Dual Slope
Signal Integration Time:	(60 Hz Standard) 16-2/3 msec 1-2/3 msec in Superfast
Reference Integration Time:	0 - 26-2/3 msec, 0 - 2-2/3 msec in Superfast
Polarity Selection:	Automatic
Ranging:	Autorangeing is standard, up-ranges at 160% F.S. and downranges at 15% F.S.
Read Rate:	3-1/3 rdg per sec to hold
Maximum Common Mode Voltage:	1000V peak or DC Guard to case with logic common tied to case. 250V analog common to guard
Display:	5 full decades plus overrange digit (LED .4 inches high) plus decimal point and function annunciator
Overrange Indication:	Maximum reading is 160000 and "NO" annunciator is illuminated
Filter:	4-pole active
Analog Signal Output:	Signal input scaled and buffered 0 to $\pm 16V$. DC voltage is available for driving a recorder or as an accurate voltage source (Internal reference only)
Power Requirement:	100 - 240V (selectable) 50 - 60 Hz Standard 400 Hz Optional 40 watts maximum
Weight:	16 lbs. (7.3 Kg)
Dimensions:	3.5" x 14" x 16.75" (89 mm x 356 mm x 425 mm)
Temperature Range:	Operating 0°C - 50°C Storage -40°C - 70°C
Humidity Operating:	<75%; 25°C - 40°C <50%; 40°C - 50°C
Fan:	None required
Vibration, Operating:	0.025" double amplitude to 50 Hz for 15 minutes
F.S. on Full Scale:	Defined as "100000" reading on any range

DC VOLTS (Included in Basic Instrument)	
Ranges:	$\pm 1.00000V$, $\pm 1.00000V$, $\pm 10.0000V$, $\pm 100.000V$, $\pm 1000.00V$
Resolution:	0.001% of range 1 μV on 0.1V range
Overrange:	60% except 1000V range (1100 maximum input)
Maximum Input Voltage:	1100 VDC or 1400V peak AC on all ranges
Accuracy:	24 hours, 23°C $\pm 1^\circ C$ (no adjustments) 10 Volt Range $\pm 0.001\%$ of full scale 1, 100, 1000 Volt Ranges $\pm (0.001\%$ of reading $+0.001\%$ of full scale) .1 Volt Range $\pm (0.002\%$ of reading $+0.005\%$ of full scale) 90 days, 23°C $\pm 5^\circ C$ (After zeroing on 0.1V Range) 10 Volt Range $\pm (0.001\%$ of reading $+0.001\%$ of full scale) 1, 100, 1000 Volt Ranges $\pm (0.002\%$ of reading $+0.001\%$ of full scale) .1 Volt Range $\pm (0.003\%$ of reading $+0.005\%$ of full scale) 1 year, 23°C $\pm 5^\circ C$ (After zeroing on 0.1V Range) 10 Volt Range $\pm (0.003\%$ of reading $+0.001\%$ of full scale) 1, 100, 1000 Volt Ranges $\pm (0.004\%$ of reading $+0.001\%$ of full scale) 0.1 Volt Range $\pm (0.005\%$ of reading $+0.005\%$ of full scale)
Temperature Coefficient:	0°C to 50°C 10 Volt Range $\pm (1.5$ ppm of reading $+5$ ppm of full scale)/°C 1, 100 Volt Range $\pm (2.5$ ppm of reading $+1$ ppm of full scale)/°C 0.1 Volt Range $\pm (4$ ppm of reading $+5$ ppm of full scale)/°C 1000 Volt Range $\pm (3$ ppm of reading $+1$ ppm of full scale)

Table 1.2 - Specifications (continued)

DC VOLTS (continued)	
Non-Linearity:	0°C to 50°C All ranges: less than or equal to .5 digit non-linearity to 160% of full scale
Input Impedances:	0.1V-10V > 10,000 MΩ 100V-1000V > 10 MΩ
Input Bias Current:	10 pA at time of calibration (±100 pA for 30 days at 25°C)
Input Bias Current Temperature Coefficient:	±5 pA/°C
Normal Mode Rejection: Unfiltered Filtered	48 dB at every multiple of 60 Hz 100 dB at 60 Hz
Common Mode Rejection: Unfiltered Filtered	(with 100Ω unbalance in either lead) 140 dB at DC, 120 dB at 61 Hz and below 140 dB DC to 61 Hz 126 dB 61 Hz to 100 kHz
Settling Time: Unfiltered Filtered	Settles to within 0.01% in 5 msec with 10 KΩ source, 10 msec on 100V range Settles to within 0.01% in 450 msec with 10 KΩ source

DATA OUTPUT (Included in the Basic Instrument)	
Information:	All BCD outputs of display, 4-bit Range code, function flags, polarity flags, special flags, and logic supplies
Logic Type:	Standard TTL levels, 8-4-2-1 BCD
Input Commands:	Superfast Data Disable System Direct Command
Maximum Read Rate:	26 per sec to full scale, 120 per sec to full scale in Superfast, 60 Hz operation
Isolation:	Data output common may be floated up to 200V peak from power line common

AC VOLTS (Option 33 AC Converter, Averaging)	
Ranges:	1.00000V, 10.0000V, 100.000V, 1000.00V RMS
Resolution:	0.001% of range 10 μV on 1V range
Overrange:	60% except 1000V range (1000V RMS maximum input)
Maximum Input Voltage:	1000V RMS or 1400V peak AC decreasing to 20V RMS at 1 MHz. 2x10 ⁷ V Hz maximum on any range
Accuracy:	24 hours, 23°C ± 1°C V _{in} ≤ 500V RMS 20 Hz to 30 Hz (filtered) ±(0.2% of reading +0.002% of full scale) 30 Hz to 60 Hz (filtered) ±(0.1% of reading +0.002% of full scale) 60 Hz to 100 Hz (filtered) ±(0.05% of reading +0.002% of full scale) 100 Hz to 5 kHz (filtered) ±(0.02% of reading +0.002% of full scale) 100 Hz to 300 Hz (no filter) ±(0.1% of reading +0.002% of full scale) 300 Hz to 5 kHz (no filter) ±(0.02% of reading +0.002% of full scale) 5 kHz to 100 kHz (both) ±(.04% of reading +0.005% of full scale) 100 kHz to 300 kHz (both) ±(0.1% of reading +0.01% of full scale) 300 kHz to 1 MHz (both) ±(0.5% of reading +0.05% of full scale) 90 days, 23°C ± 5°C add ±0.01% of reading to 24 hour specification 6 months, 23°C ± 5°C add ±0.02% of reading to 24 hour specification 1 year, 23°C ± 5°C add ±0.03% of reading to 24 hour specification V _{in} > 500V RMS f < 5 kHz Add ± .1% of reading f ≥ 5 kHz Add ± .2% of reading

AC VOLTS continued on page 1-6

Table 1.2 - Specifications (continued)

AC VOLTS (continued)	
Temperature Coefficient:	0°C to 50°C 50 Hz to 20 kHz (filtered) ±(0.003% of reading +0.0005% of full scale)/°C 20 kHz to 100 kHz (both) ±(0.005% of reading +0.002% of full scale)/°C 100 kHz to 1 MHz (both) ±(0.01% of reading +0.01% of full scale)/°C
Input Impedances:	1 MΩ ± 0.1% in series with 0.22 μF shunted by less than 100 pF to common
Common Mode Rejection:	(with 100Ω unbalance in either lead, DC to 60 Hz) 1 Volt Range 120 dB 10 Volt Range 100 dB 100 Volt Range 80 dB 1000 Volt Range 60 dB
Settling Time:	
Unfiltered	Settles to within rated accuracy in 200 msec
Filtered	Settles to within rated accuracy in 600 msec
(Zero to full scale or full scale to 10% of full scale)	

REMOTE PROGRAMMING (Option 42)

Input Information:	Provides isolated programming of all DMM functions and ranges
Logic Type:	Standard TTL levels, 8-4-2-1 BCD
Functions:	Function lines are programmed by a closure to ground (low TTL level)
Ranges:	Range lines are 8-4-2-1 coded positive true logic
Command Modes:	Direct Command Timeout Command Superfast

OHMS (Option 52)	
Ranges:	10.0000Ω, 100000 KΩ, 1.00000 KΩ, 10.0000 KΩ, 100.000 KΩ, 1000.00 KΩ, 10.0000 MΩ, 100.000 MΩ
Resolution:	0.001% of range 100 μΩ on 10Ω range
Overrange:	60% on all ranges
Maximum Input Voltage:	±500V peak on all ranges
Measurement Scheme:	True 4-wire
Accuracy:	24 hours, 23°C ± 1°C 10 ohm Range ±(0.003% of reading +0.005% of full scale) .1, 1, 10, 100, 1000 kilohm Ranges ±(0.002% of reading +0.001% of full scale) 10 megohm Range ±(0.01% of reading +0.001% of full scale) 100 megohm Range ±(0.02% of reading +0.001% of full scale) 90 days, 23°C ± 5°C 10 ohm Range ±(0.005% of reading +0.005% of full scale) .1, 1, 10, 100, 1000 kilohm Ranges ±(0.003% of reading +0.001% of full scale) 10 megohm Range ±(0.03% of reading +0.001% of full scale) 100 megohm Range ±(0.03% of reading +0.001% of full scale)
Temperature Coefficient:	0°C to 50°C 10 ohm Range ±(8 ppm of reading +5 ppm of full scale)/°C .1, 1 kilohm Ranges ±(7 ppm of reading +1 ppm of full scale)/°C 10, 100, 1000 kilohm Ranges ±(6 ppm of reading +1 ppm of full scale)/°C 10 megohm Range ±(30 ppm of reading +1 ppm of full scale)/°C 100 megohm Range ±(50 ppm of reading +3 ppm of full scale)/°C

Table 1.2 - Specifications (continued)

OHMS (continued)	
Open Circuit Voltage:	10 Ω -1 K Ω 2.5V maximum 10 K Ω -100 M Ω 22V maximum
Current Through Unknown:	10 ohm Range 10.1 mA 100 ohm Range 11.1111 mA 1 kilohm Range 1.11111 mA 10 kilohm Range 1 mA 100 kilohm Range 100 μ A 1000 kilohm Range 10 μ A 10 megohm Range 1 μ A 100 megohm Range 100 nA
Normal Mode Rejection: Unfiltered Filtered	48 dB at every multiple of 60 Hz 100 dB at 60 Hz
Settling Time: to rated accuracy	10 Ω -10 M Ω 30 msec 100 M Ω 300 msec
Ohms Guard:	Use "Analog-Out" low on rear panel when in ohms

SUPERFAST	
Ranges & Functions:	All ranges and functions
Command:	Must be commanded through rear printer connector (J201), or through programmer option (J202).
Display:	Four digit display with 60% overrange
Maximum Read Rate:	(60 Hz standard) 98 readings/sec. minimum at full overrange. 120 readings/sec. at full scale
Accuracy:	Standard accuracy for range and function plus .03% of reading plus .03% of full scale

3-WIRE RATIO (Included in Basic Instrument)	
3-Wire (Standard)	ac/dc, dc/dc
Readout:	$\frac{(10V)}{(\text{Ref } V)} \times \frac{(\text{Input})}{(\text{F.S. of range})} \times 10$
Reference Voltage Range:	+1V to +10.5V
Maximum Input Voltage:	Same as function
Accuracy:	24 hours, 23 $^{\circ}$ C \pm 1 $^{\circ}$ C DC, AC – same as respective 24 hour, 23 $^{\circ}$ C \pm 1 $^{\circ}$ C spec. times $\frac{(10V)}{(\text{Ref } V)}$
Reference Input Impedance:	1000 M Ω
Reference Settling Time:	10 msec to 0.01% accuracy

4-WIRE RATIO (Option 62)	
4-Wire (Option 62)	ac/dc, dc/dc
Readout:	$\frac{(10V)}{(\text{Ref } V)} \times \frac{(\text{Input})}{(\text{F.S. of range})} \times 10$
Reference Voltage Range:	+1V to +10.5V
Maximum Input Voltage:	Same as function
Accuracy:	24 hours, 23 $^{\circ}$ C \pm 1 $^{\circ}$ C DC, AC – same as respective 24 hour, 23 $^{\circ}$ C \pm 1 $^{\circ}$ C spec. times $\frac{(10V)}{(\text{Ref } V)} \times 2$
Reference Input Impedance:	(Both leads with respect to –sig. input) 1000 M Ω min. + lead 3.3x10 M Ω \pm 10% – lead
Reference Input to Sig. Common Voltage:	\pm 15V max. (either input)
Reference Settling Time:	50 msec to 0.01% of rated accuracy
Reference Common Mode Rejection:	100 dB

Table 1.2 - Specifications (continued)

AC VOLTS TRUE RMS (Option 32)	
Ranges:	1.00000V, 10.0000V, 100.000V, 1000.00V RMS
Resolution:	0.001% of range 10 μ V on 1V range
Overrange:	60%, (within maximum input voltage limit)
Maximum Input Voltage:	1000V DC/RMS or 1500V peak, decreasing to 20V RMS at 1 MHz. 2×10^7 VHz maxi- mum on any range
Maximum Crest Factor: (Pulses at 1 kHz Repetition Rate)	7:1 at full-scale $7 \times \sqrt{\frac{\text{F.S.}}{V_{\text{input}}}}$ for other voltages
Accuracy: AC Mode NOTE Accuracy is defined only for values be- tween .1% and 160% of full scale (full scale specified as 100,000 counts).	90 days, 23°C \pm 5°C 20 Hz – 30 Hz (filtered) \pm (.5% of reading +.04% of full scale) 30 Hz – 50 Hz (filtered) \pm (.2% of reading +.04% of full scale) 50 Hz to 100 Hz (filtered) \pm (.1% of reading +.04% of full scale) 100 Hz – 20 kHz (filtered) \pm (.07% of reading +.04% of full scale) 200 Hz to 20 kHz (no filter) \pm (.07% of reading +.04% of full scale) 20 kHz – 50 kHz (both) \pm (.1% of reading +.1% of full scale) 50 kHz – 100 kHz (both) \pm (.4% of reading +.2% of full scale) 10, 100, 1000V range 100 kHz – 300 kHz \pm (3% of reading +.5% of full scale) 1V range 100 kHz – 300 kHz \pm (5% of reading +1% of full scale)

Accuracy: (con't) AC Mode (continued)	6 months, 23°C \pm 5°C 1, 10, 100, 1000V ranges 20 Hz – 50 kHz Add \pm .01% reading \pm .01% full scale to the 90 day spec. 50 kHz – 100 kHz Add \pm .02% reading \pm .02% full scale to the 90 day spec. 100 kHz – 300 kHz Add \pm 1% reading \pm .1% full scale to the 90 day spec.										
DC Mode	Add \pm .02% of full scale to AC specification										
For inputs greater than 500V add .1% of reading to above spec											
For inputs greater than 150V, Filter should be "IN".											
Temperature Coefficient:	0°C to 50°C AC Mode (to 20 kHz) \pm (.004% of reading +.003% of full scale)/°C DC Mode (to 20 kHz) \pm (.004% of reading +.005% of full scale)/°C										
Input Impedances: AC Mode	1 Megohm \pm 0.1% in series with 0.22 μ F shunted by less than 100 pF to common										
In dc mode, the .22 μ F capacitor is shorted											
Common Mode Rejection: With 100 Ω unbalance in either lead. DC to 60 Hz	<table border="1"> <thead> <tr> <th>Range</th> <th>CMR</th> </tr> </thead> <tbody> <tr> <td>1V</td> <td>120 dB</td> </tr> <tr> <td>10V</td> <td>100 dB</td> </tr> <tr> <td>100V</td> <td>80 dB</td> </tr> <tr> <td>1000V</td> <td>60 dB</td> </tr> </tbody> </table>	Range	CMR	1V	120 dB	10V	100 dB	100V	80 dB	1000V	60 dB
Range	CMR										
1V	120 dB										
10V	100 dB										
100V	80 dB										
1000V	60 dB										
Settling Time: (exclusive of DC component)	(to within .1% of range)										
Filter Out	0 to Full Scale Step										
Filter In	80 msec										
	350 msec										
Filter Out	Full Scale to 10% FS Step										
Filter In	100 msec										
	400 msec										

Table 1.2 - Specifications (continued)

50 Hz OPERATION (Option 04)	
For instruments modified for operation at 50 Hz line frequency, the specifications are the same as 60 Hz operation except as follows:	
Signal Integration Time:	20 msec 2 msec in Superfast
Reference Integration Time:	0 - 32 msec 0 - 3.2 msec in Superfast
Normal Mode Rejection:	
Unfiltered	48 dB at every multiple of 50 Hz
Filtered	100 dB at 50 Hz

Table 1.3 - Model 55 GPIB Specifications

MODEL 55 GPIB SPECIFICATIONS	
Output Information:	Numeric data, polarity, function, and special flags
Data Output Format:	DC, AC, Ratio: same as front panel display with no leading zero suppression. Ohms: readout expressed as kohms
Input Information:	Functions, ranges, and filter
Command Modes:	Direct Command Timeout Command Superfast
Electrical Compatibility:	IEEE Std. 488-1975
Information Format:	7-bit ASCII code
Power Requirement:	20 Watts maximum
Line Voltage:	100/120/220/240V $\pm 10\%$ 48 - 440 Hz
Weight:	3.2 Kg (7 lb.)
Dimensions:	44mm x 356mm x 425mm (1.75" x 14" x 16.75")

SECTION 2

INSTALLATION & OPERATION

2.1 UNPACKING AND INSPECTION.

2.2 The Model 5900 DMM is packed in a molded plastic-foam form within a cardboard carton for shipment. The plastic form holds the DMM securely in the carton and absorbs any reasonable external shock normally encountered in transit. Prior to unpacking, examine the exterior of the shipping carton for any signs of damage. Carefully remove the DMM from the carton and inspect the exterior of the instrument for any signs of damage. If damage is found, notify the carrier immediately.

2.3 Included with the instrument in the packing container are the instruction manual, power cord, and rear input and BCD output mating connectors. With instruments equipped with remote programming, a mating connector for that accessory is included.

2.4 BENCH OPERATION.

2.5 Each Model 5900 is equipped with a tilt bail or "kickstand" to enable the front of the instrument to be elevated for convenient bench use. The tilt bail is attached to the two front supporting "feet" at the bottom of the instrument. For use, the bail is pulled down to its supporting position.

2.6 RACK MOUNTING.

2.7 The instrument can be mounted in a standard 19-inch rack with the optional rack-mounting flanges (403402, includes attaching hardware). To install the flanges, proceed as follows:

- a. With instrument on its side, remove four Phillips-head screws holding bottom cover. Remove cover. Remove screws holding feet (and bail) in place. Replace bottom cover.
- b. Place one of the supplied screws through each of the two holes in the mounting flange (figure 2.1). Thread a securing nut onto each screw just enough to attach it to the screw (approximately one turn).
- c. Place the mounting flange onto the mounting slot in the instrument side panel so that the securing nuts fit entirely into the slot. Be sure the rack-mount slots on the flange are toward the front of the instrument.
- d. Tighten screws. The securing nuts will rotate and hold the flange securely in place.

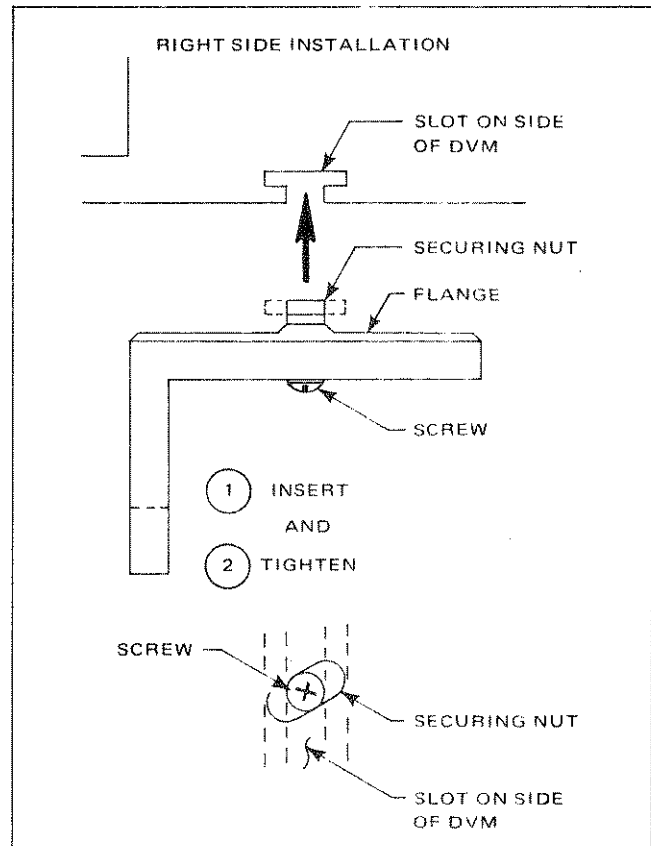

Figure 2.1 - Rack Mount Installation

2.8 POWER CONNECTIONS.

2.9 Standard units operate on either 115 volts or 230 volts, 50 to 60 Hz (400 Hz available). Power consumption is less than 40 watts. Operation on either of the two line voltages is selectable by a slide switch on the rear panel. Operation on 100/200 volts or 120/240 volts is possible by simple rewiring of the power transformer secondary wires:

WARNING

Disconnect the instrument from the AC Power source before attempting to change power connections. Potentially lethal voltages are exposed when covers are removed.

- a. For operation on 100/200 volts, cut the brown wire 1" from the transformer and splice it to the red wire on the transformer; cut the blue wire 1" from the transformer and splice it to the violet wire.
- b. For operation on 120/240 volts, cut the brown wire 1" from the transformer and splice it to the black wire; cut the blue wire and splice it to the yellow wire on the transformer.

2.10 A standard power cable having a three-pin plug is supplied with the instrument. It connects to POWER connector J203. The ground pin (round) is attached to the instrument case. It is important that this pin be connected to a good quality earth ground.

2.11 Fuse receptacle F201 on the rear panel is equipped with a .5 amp fuse.

2.12 INPUT/OUTPUT CABLING.

2.13 Binding Posts.

2.14 Several connectors on the Model 5900 consist of a pair of binding posts spaced so as to accept standard "banana" plugs. The connectors are:

Front Panel	Rear Panel
± INPUT	± ANALOG OUTPUT
± OHMS CURRENT	± REFERENCE INPUT
GUARD	

2.15 Input cables to fit this type of connector can be ordered from Dana (P/N 402190). Figure 2.2 is a wiring diagram of this cable included for assistance to users desiring to construct their own cables.

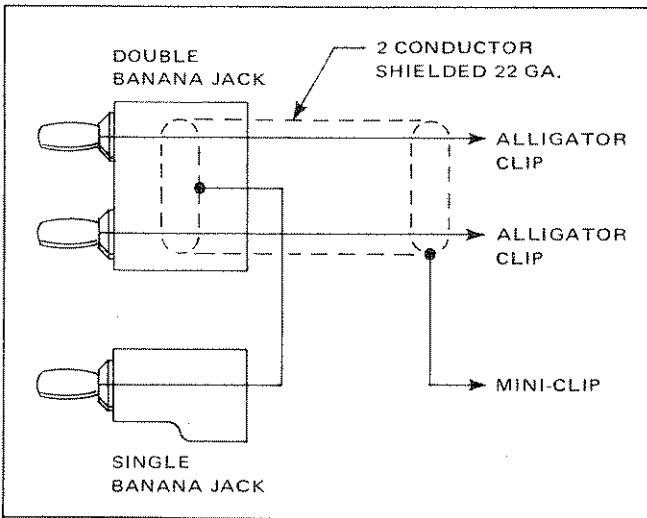

Figure 2.2 - Cabling Diagram, Binding Posts

2.16 Rear Input Connector.

2.17 Instruments equipped with the -1 or -1S rear input option are supplied with J204 7-pin input connector (Dana P/N 600673) and a mating connector (Dana P/N 600616). On instruments equipped with -1B or -1SB J204 is Dana P/N 600259 and the mating connector is Dana P/N 600260. The instrument accepts inputs applied to this connector or inputs applied to the front-panel binding posts. The rear-

panel input lines are wired in parallel with the front-panel input lines. It is recommended that the cable for the mating connector be constructed as shown in figure 2.3 using two two-conductor shielded cables. Other configurations may be desirable depending on the ohms measuring method to be used (see paragraph 2.28).

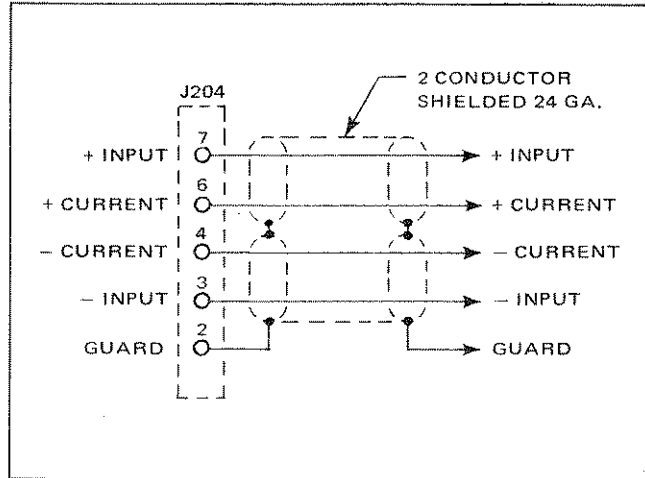

Figure 2.3 - Cabling Diagram, Rear Input

2.18 MANUAL OPERATION.

2.19 Controls.

2.20 All operating controls are located on the front panel of the instrument. They are shown in figure 2.5 and their operation described in table 2.1. Description of Systems operation begins in paragraph 2.44.

2.21 DISPLAY.

2.22 The display consists of 6 LED decimal readout devices with moving decimal point. The decimal point moves in conjunction with the range switch or automatically in auto range. Maximum usable readout with overrange is 159999. Overload is indicated by a NO and 160000 readout. A non-compatible range and function is indicated by a NO. However, mechanical interlocks are provided to prevent illegal combinations from the front panel. Figure 2.4 illustrates the readout, NO indicator, polarity sign and the annunciator.

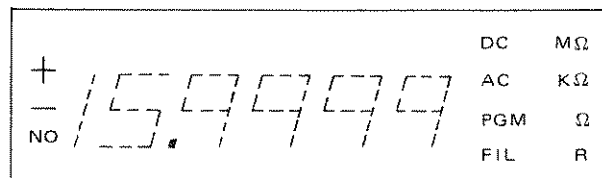

Figure 2.4 - Readout

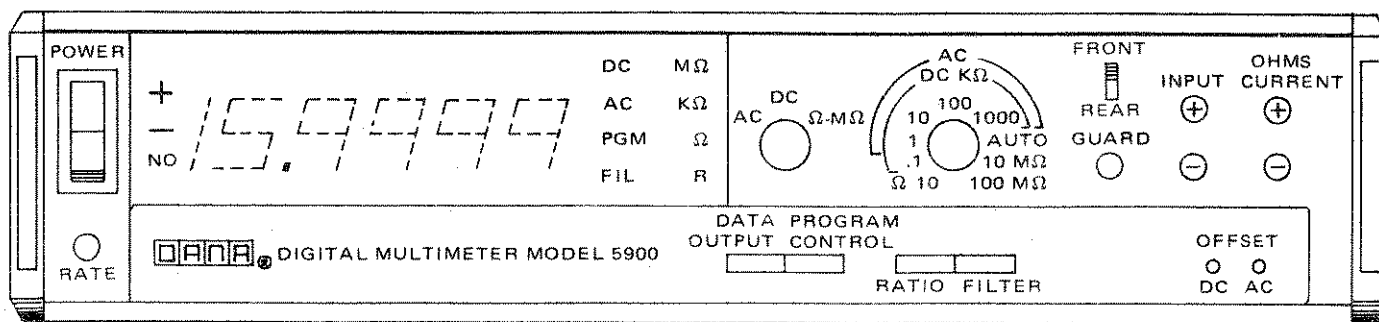

Figure 2.5 - Front Panel

Table 2.1 - Operating Controls

Control	Position	Function
Power (rocker switch)	ON (up)	Applies power to instrument
	OFF (down)	Removes power from instrument
Function Select (rotary switch)	AC†	Selects the measurement of AC voltages on the 1, 10, 100, and 1000 volt ranges (max. input, 1000V RMS)
	DC	Selects the measurement of DC voltages on the .1, 1, 10, 100, and 1000 volt ranges (max. input, 1100V)
	Ω-MΩ*	Selects the measurement of resistance on the 10 ohm range; on the .1, 1, 10, 100, and 1000 kilohms ranges; or on the 10 or 100 Megohm ranges
Range Select (rotary switch)	AUTO	Selects Auto Range in which the optimum range is selected automatically by internal circuits. Uprange occurs at 160% of full scale; downrange occurs at 15% of full scale
	Other Positions	Enables manual selection of fixed ranges. Ranges permissible for each function are inscribed on the panel
DATA OUTPUT (pushbutton)	Depressed	Enables the print pulse causing BCD data at P201 to be recorded by printer, or other output device. (Output data is present at P201 regardless of the position of this switch.)
PROGRAM CONTROL (pushbutton)	Depressed	Enables the selection of range, function, and mode to be made externally through the remote programming connector and disables all front panel controls (requires programming option)
RATIO (pushbutton)	Depressed	Selects a ratio measurement in which the readout represents the ratio of the input to an external d-c reference voltage (applied at terminals on the rear panel) multiplied by 10: $E_{in}/E_{Ref} \times 10$
FILTER (pushbutton)	Depressed	Adds an active four-pole filter across the input circuit
RATE (pot)	EXT (ccw)	Selects the Ho'd mode. A new reading is initiated through the remote program input
	CW	Increase periodic read rate to a maximum of four readings/second
FRONT/REAR (Optional) (slide switch)	FRONT	Connects front panel data input terminals to instrument
	REAR	Connects rear panel data input terminals to instrument

*NOTE: Ohms input terminals are open in AC or DC function.

†NOTE: For inputs greater than 150V, Filter should be "IN".

2.23 MEASUREMENT CONNECTIONS.

NOTE

Before taking any measurements, refer to the list of maximum input voltages, table 2.2.

Table 2.2 - Maximum Input Voltage

CAUTION

Do not exceed the following maximum inputs:

DC	1100 VDC or 1000V RMS AC
AC	1000V RMS decreasing to 20V RMS at 1 MHz (see figure 2.7)
Ω	$\pm 500V$ peak between +I and -I (1000V RMS if in DC or AC function.)
RATIO	Input: same as function selected Reference: +10.5V, -0.5V
GUARD	Voltage between GUARD and - INPUT must not exceed 250 volts or damage to the instrument may result

2.24 Basic Voltage Measurement.

2.25 An ac or dc voltage measurement connection recommended to minimize the effects of noise requires a two-conductor shielded cable connected as shown in figure 2.6.

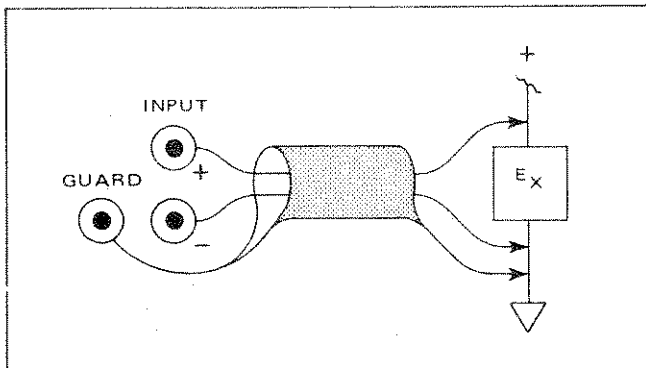

Figure 2.6 - Basic Voltage Measurement Connections

2.26 For all voltage measurements, the GUARD lead and the - INPUT lead are connected to the measurement point nearest ground potential. Somewhat less shielding is

achieved by placing a shorting bar between - INPUT and GUARD and shorting the single banana plug (shield) to the - INPUT side of the double banana plug at the input connector. This arrangement is adequate for measuring all but low voltage (mV) levels and/or in high-noise environments.

2.27 When making "floating" voltage measurements (both measurement points above ground potential), do not connect GUARD to measurement ground without making sure that the voltage between GUARD and - INPUT does not exceed 250 volts.

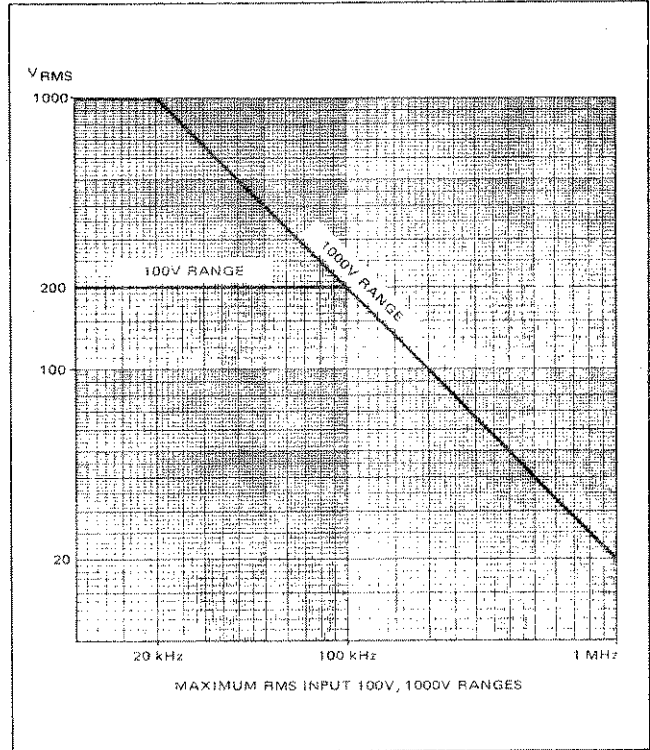

Figure 2.7 - Maximum RMS Input Voltage

2.28 Ohms Measurement.

2.29 Ohms measurement in the Model 5900 consists of the application of a known current through the unknown resistance (R_X) and measuring the ratio of the voltage drop across R_X to the drop across an internal "full-scale" resistor ($E_{R_X}/E_{F.S.}$). Current through R_X is applied through leads from the \pm OHMS CURRENT terminals. The voltage drop is sensed by the \pm INPUT terminals.

2.30 TWO-WIRE MEASUREMENTS.

2.31 Connections for a simple two-wire shielded ohms measurement are shown in figure 2.8a. It consists simply of a single-conductor shielded cable with the conductor serving as both the + CURRENT and + INPUT leads and the shield

(a)

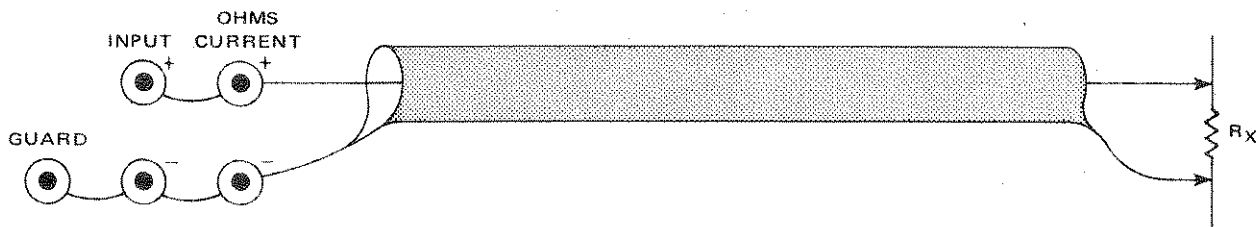

USED FOR NORMAL MEASUREMENTS ON ALL BUT THE 10 and 100Ω RANGES.

(b)

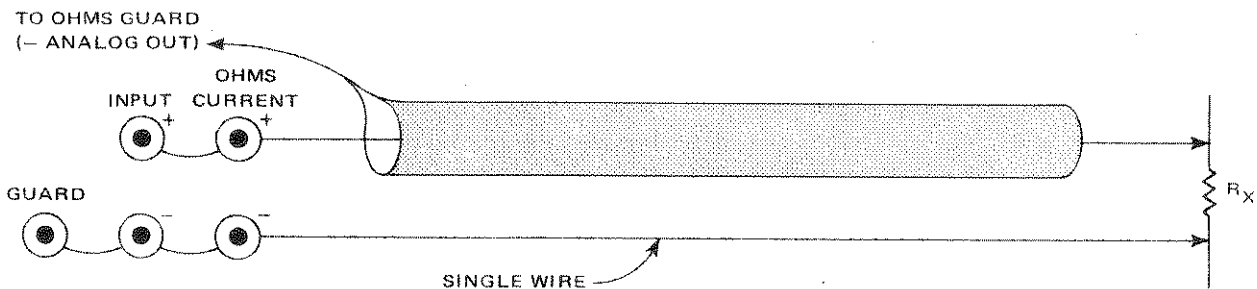

USED ON 100 MΩ RANGE WHERE CABLE LEAKAGE IS A PROBLEM.

(c)

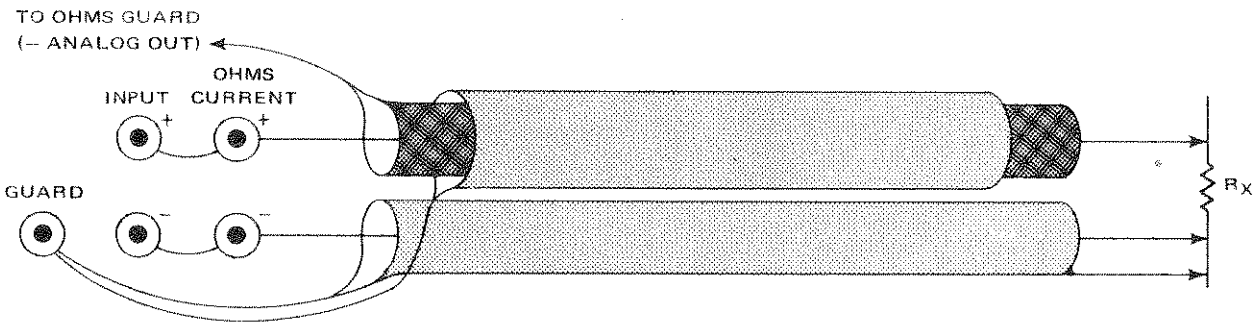

USED ON 100 MΩ RANGE IN HIGH-NOISE ENVIRONMENT; MINIMIZES BOTH NOISE AND LEAKAGE PROBLEMS.

Figure 2.8 - Two Wire Ohms Measurements

(a)

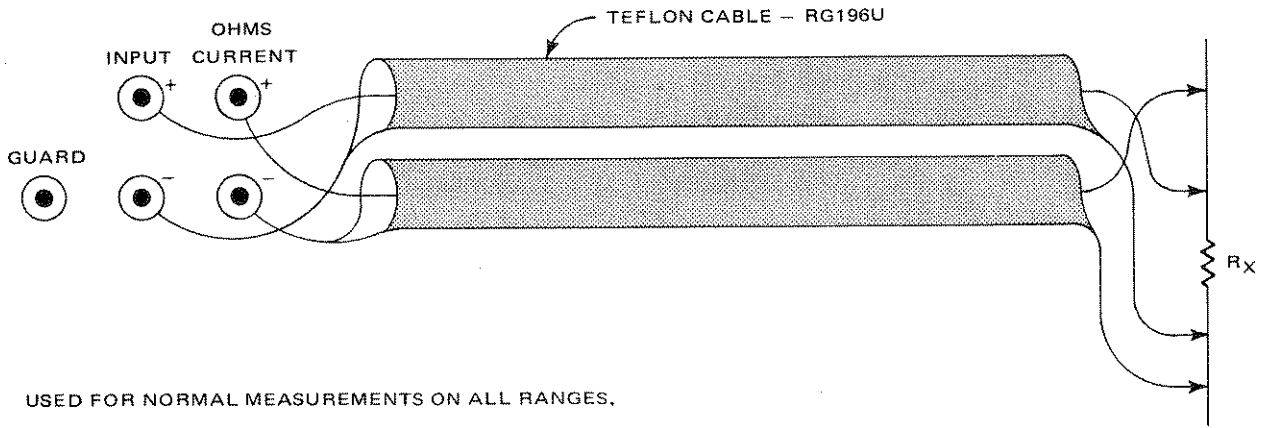

(b)

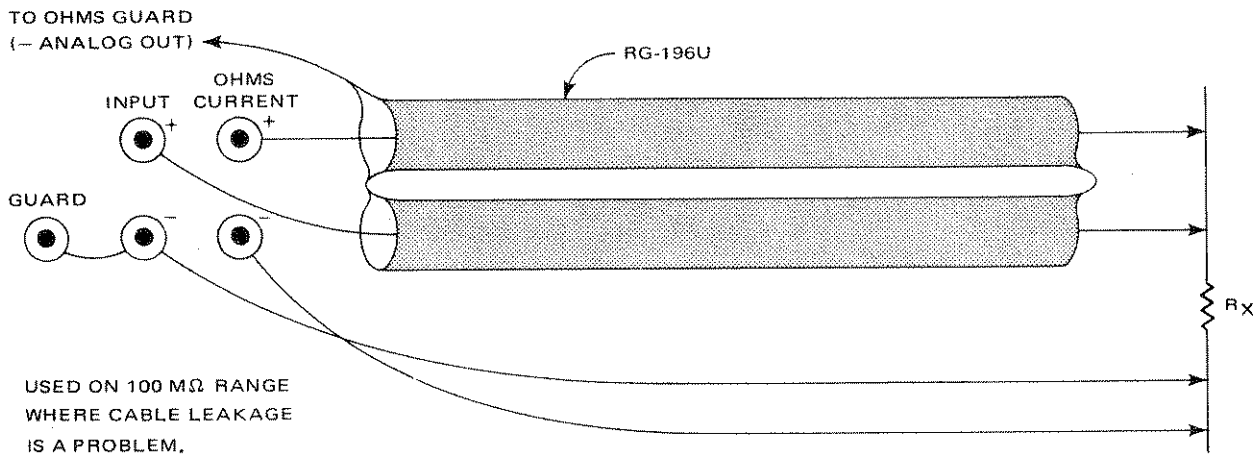

(c)

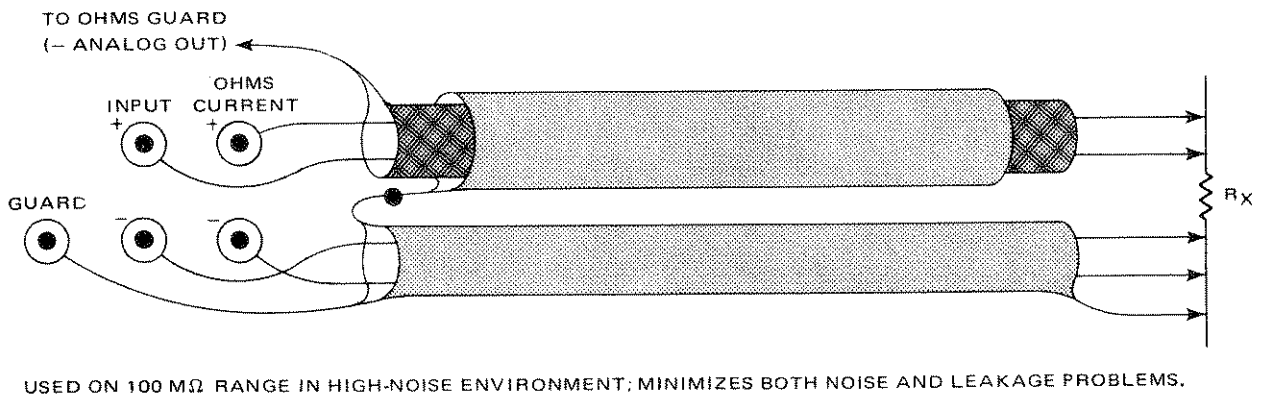

Figure 2.9 - Four Wire Ohms Measurement

carrying – CURRENT and – INPUT. While reasonably accurate measurements can be made with this method, shunt leakage problems result from the parallel combinations of R_x and the cable impedance. This causes loss of accuracy, especially at high resistance (100 M Ω range). Also, lead resistance becomes a factor in the 10 and 100 ohms ranges; the four wire measurement system is recommended for these ranges.

2.32 A more accurate two-wire measurement connection is shown in figure 2.8b. The + INPUT and + CURRENT, – INPUT and – CURRENT terminals are again tied together. But now, the positive side is a single-conductor, shielded cable with the shield tied to Ohms Guard. Ohms Guard is the low ANALOG OUTPUT terminal on the rear panel of the Model 5900 when ohms is selected. The negative side is a single wire connected as shown. Guard current is present in the low side, but the leakage problems of the first configuration are eliminated.

2.33 In high noise-level environments, the configuration shown in figure 2.8c is recommended. This method also eliminates error due to shunt leakage, but provides more complete shielding. The positive terminals are tied together and carried in a single-conductor, double-shielded cable with the inner shield tied to Ohms Guard (– ANALOG OUTPUT). The outer shield is tied to GUARD. The negative terminals are tied together and carried in a single-conductor shielded cable with the shield tied to GUARD. This configuration eliminates guard current sensitivity, thereby increasing guarding characteristics.

2.34 FOUR-WIRE MEASUREMENTS.

2.35 In most system applications, the device to be measured is located at a remote location requiring interconnection by cables of lengths from several to possibly hundreds of feet. When measuring low resistance values over long cables, most lead resistance problems can be solved by the use of a four-wire measurement system.

2.36 For high resistance measurements over long cables, other problems are encountered: noise pick-up, leakage resistance, and capacitive loading of the system. These problems can be minimized by proper shielding and the use of ohms guard.

2.37 Figure 2.9a shows a basic shielded four-wire ohms measurement configuration. This method uses two single-conductor shielded teflon cables. The conductors carry the positive sides of the INPUT and CURRENT lines while each shield carries the low side.

2.38 This configuration, although shielded, places the shield capacitance and cable leakage in parallel with R_x . This results in loss of accuracy and slow measurements. In addition, it is very responsive to the triboelectric effect at high resistance measurements.

2.39 Better guarding is achieved by the use of the configuration shown in figure 2.9b. Here again, RG196U teflon dielectric cable (either single-conductor shielded or two-conductor shielded) is used on the positive terminals. The shield(s) are connected to Ohms Guard (low ANALOG OUTPUT terminal). The negative leads are single wires with the – INPUT terminal tied to GUARD.

2.40 This eliminates much of the shunt leakage problem of the previous configuration since guard current now flows through the low side of the measurement circuit. Measurement is much faster since the shield capacity is driven by the guard current.

2.41 A high-noise environment calls for the “super” configuration shown in figure 2.9c. Here, a two-conductor, double-shielded cable is used as the positive leads. The inner shield is tied to Ohms Guard. A two-conductor shielded cable is used as the negative leads. Its shield is tied to GUARD and to the outer shield of the positive cable. The shield is also tied to – CURRENT at the measurement point. This configuration maintains high guarding characteristics while eliminating guard current sensitivity.

2.42 Ratio Measurements.

2.43 Ratio measurements are made by applying a positive d-c voltage to the reference input terminals on the rear panel and an input signal of any function at the front input terminals. For DC/DC or AC/DC ratios, the reference voltage must be within the range of +1V to +10.5V. Input signal limitations (numerator) are the same as those given for conventional measurement of the particular function (table 2.2). The readout is the ratio multiplied by ten: $E_{\text{input}}/E_{\text{reference}} \times 10$. In the standard instrument the – INPUT terminal is internally connected to the – REF input terminal; in instruments equipped with the option 62 4-wire ratio, both reference inputs are floating (33 M Ω between – REF and – SIGNAL). For bridge applications the 33 M Ω resistor (R16) may be removed to eliminate loading errors.

2.44 SYSTEM CAPABILITIES.

2.45 The 5900 has two system interface connectors designated as J201 (PRINTER OUTPUT) and J202 (PROGRAM INPUT) mounted on the rear panel of the instrument (figure 2.10). The following is a brief description of the capabilities of each connector.

2.46 Printer Output - J201.

2.47 Through this connector the 5900 supplies BCD representations of the decimal display; various flags or indicators of the mode of operation, function and range; and a print command. Provision has also been made for 60 Hz instruments to accept a fast (20 readings per second maximum) or a superfast (101 readings per second minimum) read command. In 50 Hz units, the fast command obtains 17 readings per second, minimum, and the superfast command 93 readings per second.

2.48 Program Input.

2.49 Through this connector the 5900 receives externally generated signals that select the function, range, mode of operation, and initiate the read commands.

2.50 LOGIC LEVELS AND ELECTRONIC INTERFACE.

2.51 TTL-compatible positive-true logic levels are used in the 5900. In some instances, however, complementary signals are used. These terms are more specifically defined below:

Signals and Their Complements --

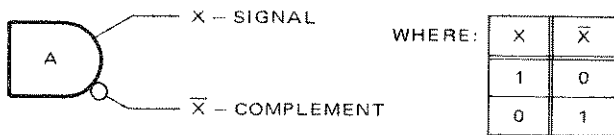

2.52 If the non-inverting output of gate A is defined as signal X, then it follows that the inverting output is \bar{X} ; in

other words, the complement of X is \bar{X} . The truth table shows that the two signals X and \bar{X} , are by definition, in opposite logic states (see table 2.3).

Table 2.3 - Positive True Logic Relationships

Signal	Logic State	Voltage Level of Output Line "X"	Voltage Level of Output Line " \bar{X} "
"X"	True or "1"	2.4 - 5.0 Volts	0.0 - 0.4
	False or "0"	0.0 - 0.4 Volts	2.4 - 5.0

2.53 As seen above, if gate A has a true or "1" level on output X, its voltage level is the most positive of the two ranges present, and output \bar{X} must be in a false or "0" state with the lowest or most negative voltage range present. The reverse would be true for a false or "0" level on output X.

2.54 Driving the Inputs.

2.55 All inputs are TTL compatible and most are the equivalent of one 7400 series TTL input with a pull-up resistor for contact closure operation.

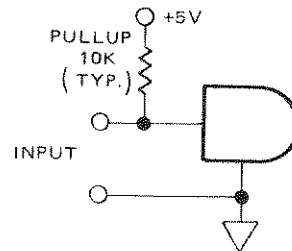

2.56 TTL Loading Conditions.

2.57 To input a "1" level the pull-up resistor will supply the necessary source current (40 μ A) to maintain the minimum 2.4 volts. In fact, the pull-up resistor will maintain a

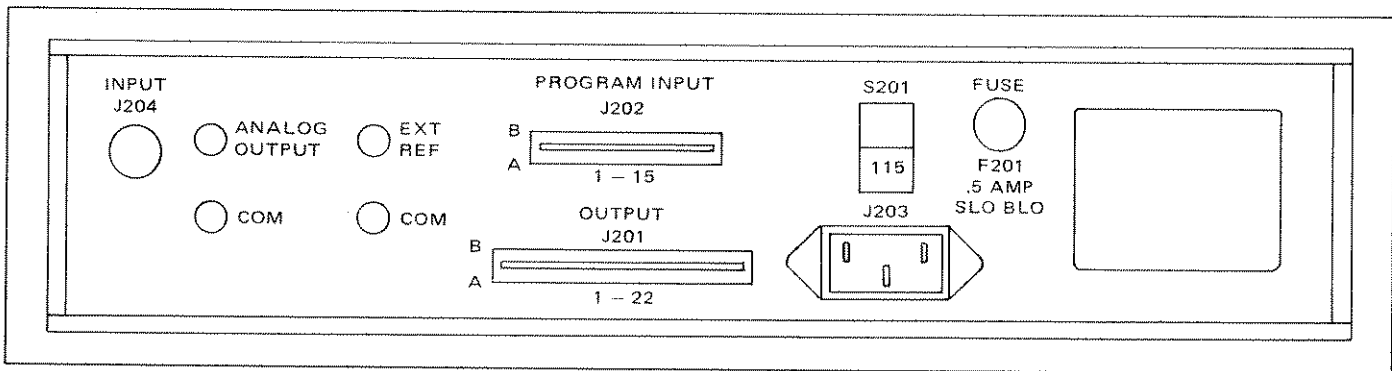

Figure 2.10 - Rear Panel

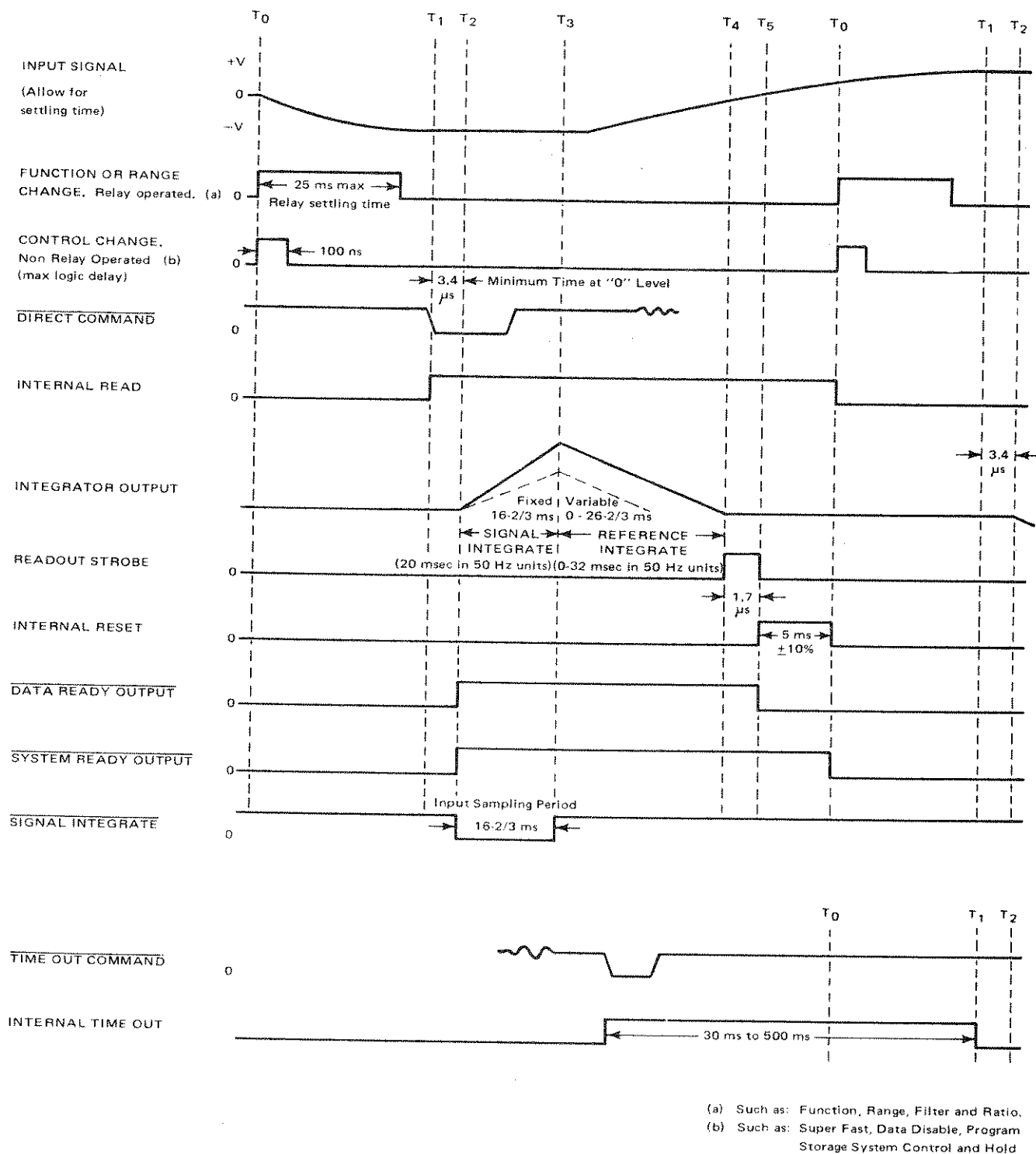
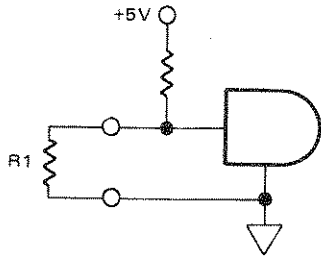

Figure 2.11 - Measurement Sequence

ne level as long as the input source resistance (R1) to ground is greater than 15K ohms.



.58 To input a "0" level, at least 2.0 ma of current must be sunk maintaining the input voltage below 0.4 volts. This requires a resistance to ground of 200 ohms or less.

2.59 Exceptions to Input Loading Conditions.

- Program Storage Input (J202, pin B-15) is the equivalent of 3 TTL inputs and requires a minimum 5.8 ma sinking current, or 68 ohms or less to common.
- Maximum input voltage level, referenced to common, must not exceed 5.5 volts peak. Otherwise, gate destruction will occur.
- The Direct and Time Out Commands are AC coupled with pull-up resistors to +5 volts. These inputs are compatible with TTL outputs or contact closures to ground. The AC coupling does require that rise and fall times be less than 100 μ seconds. This input circuit is illustrated below:

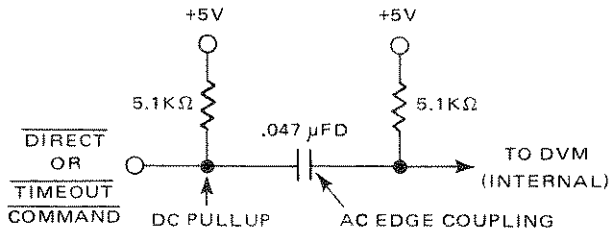

- Digital output common can be floated as high as 200 VDC above power line ground.

2.60 TTL Output Capabilities.

.61 The 5900 electrical outputs are specified to drive two TTL inputs such as described in the TTL loading section. Summary:

- False: 0 to +0.4V
- True: +2.4 to +5.0V
- Fan out: 2 minimum
- Maximum Capacitance Load: 500 pF

2.62 Timing Sequence.

2.63 The standard remote mode of operation of the 5900 is to initiate a reading sequence with each Direct Command received through the programmer, providing that sufficient time has been allowed between commands for the reading to be completed. This reading sequence is illustrated in figure 2.11.

$T_1 - T_0$ During this period the input signal must finish settling to within the desired accuracy. Any control changes involving the 25 msec relay settling time (a) can be completed; other logic control inputs (b) can also be changed.

$T_2 - T_1$ The Direct Command signal, which is AC coupled, must meet the following conditions:

- Rise and fall times less than 100 μ sec.
- Signal must stay in the logical "0" state for at least 3.4 μ sec. If these conditions are met, the internal read command is sustained at T_2 and the signal integrate period is started.

$T_3 - T_2$ The period of signal integration lasts for 16-2/3 msec (60 Hz line frequency; 20 msec in 50 Hz units). During this time the integrator charges to a voltage proportional to the input voltage. This is the input sampling period.

$T_4 - T_3$ During this period, the integrator is isolated from the input signal, and is discharged at a precise current. The time the integrator requires to discharge to a level equal to its voltage at T_2 is proportional to the input voltage. This time is measured by an internal counter and stored.

$T_5 - T_4$ This 1.7 μ sec period is required to strobe the new reading from the internal counter into the readout latches.

$T_0 - T_5$ This 5 mseconds ($\pm 10\%$) is required to reset the internal logic for the next reading.

$T_1 - T_0$ If the next read command is a Direct Command, this period must be made long enough to allow for the condition covered in the first cycle; however, if the next command is a Timeout Command, this period can approach zero since the necessary timeout to satisfy these conditions are automatically programmed.

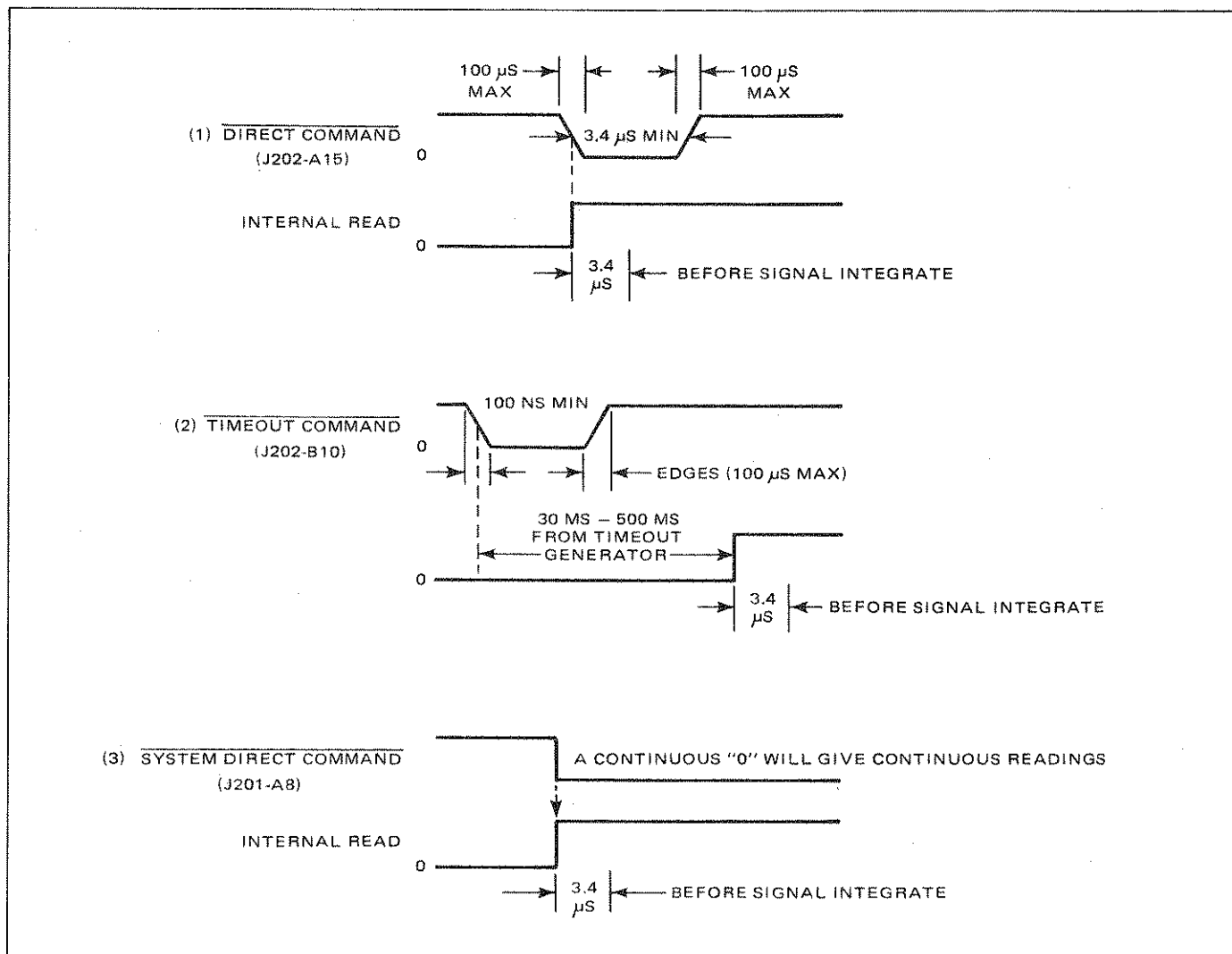

Figure 2.12 - Command Timing

2.64 Other Read Command Options.

2.65 In addition to the Direct Command, there are two other programmable read commands, as illustrated in figure 2.12.

- a. Time Out Command: Again, this is an AC coupled input which must have rise and fall times of less than $100 \mu\text{seconds}$ but must remain in a "0" state for at least $0.1 \mu\text{second}$. The timeouts given in table 2.7 for various combinations of ranges and functions ranging from 30 msec to 500 msec will be automatically inserted before the internal read command is generated. If this command is wired to the Data Ready Output on J201 - pin A11, fully automatic reading with timeouts is achieved.

NOTE

The 5 msec internal delay is not adequate for settling time on the 100 VDC, 1000 K Ω , 10 M Ω , 100 M Ω ranges, or any AC range. Therefore, the timeout command, providing timeout delays listed in table 2.7, must be used to initiate accurate readings on these ranges unless a fixed range and function have been programmed and the input has been present longer than the timeout period.

- b. System Direct Command: While the other two read commands were AC coupled and programmed through the Program Input Connector (J202), this command is DC coupled and programmed through

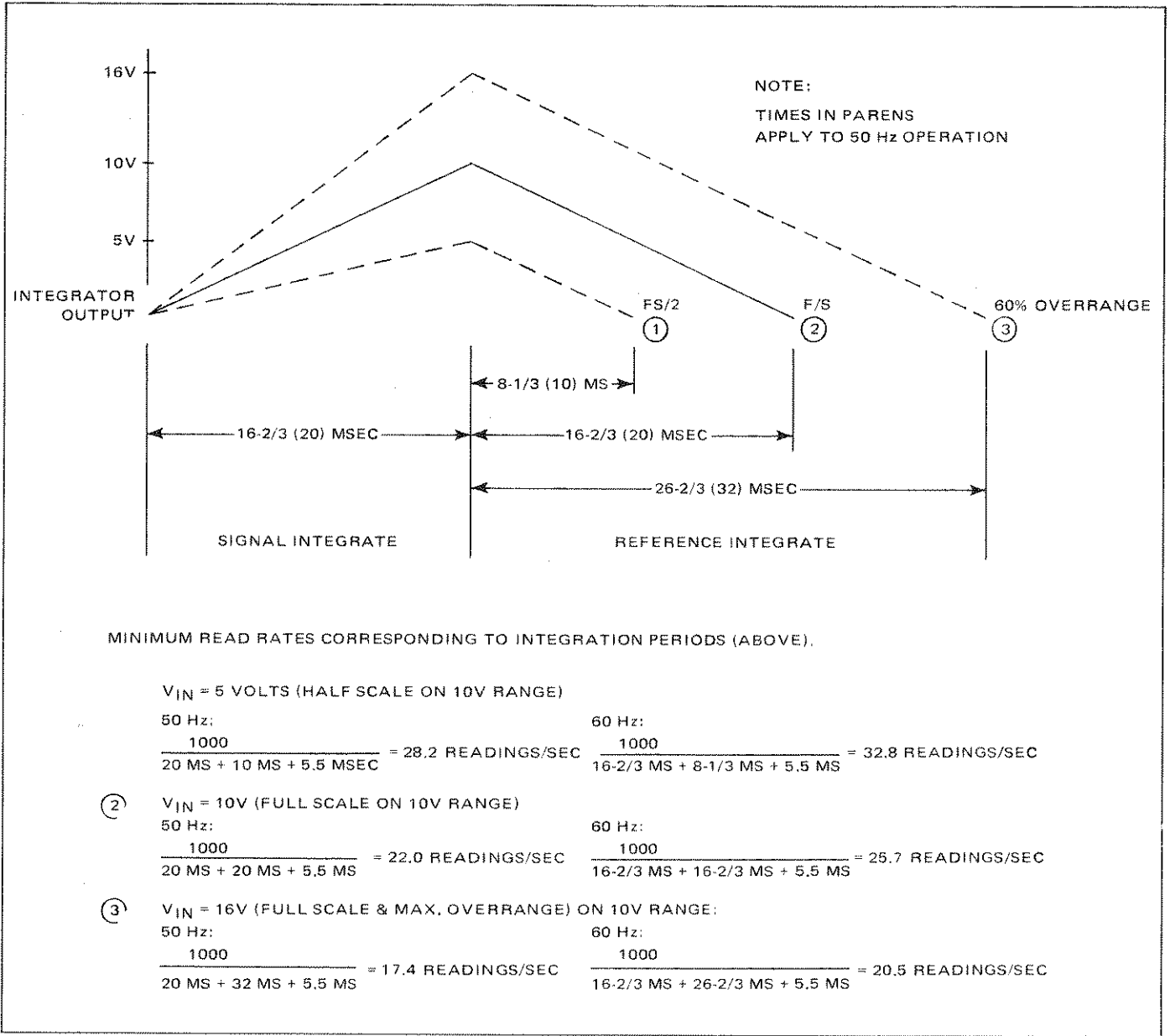

Figure 2.13 - Minimum Read Rate vs. Input

the Printer Output Connector (J201). The System Direct Command must remain in the "0" state for at least 3.4 μ seconds to generate the internal read command. This delay, as in the Direct Command, is to prevent noise from triggering the readings. If this command is tied to ground, the 5900 will recycle at its maximum reading rate with no timeouts.

2.66 Reading Rates.

2.67 In figure 2.13, integrator operation with three different input signal levels is illustrated: half scale, full scale,

and 160% of full scale (full scale is defined as 100000 on any range). The figure shows that the maximum reading rate is a function of the input signal. The signal integrate period and internal reset remain fixed while the reference integrate period can vary from 0 to 32 mseconds. Therefore the maximum read rate could vary from 17.4 to 45 reading per second.

2.68 Superfast.

2.69 The Superfast reading mode (programmed through either the PRINTER OUT or PROGRAM INPUT connector)

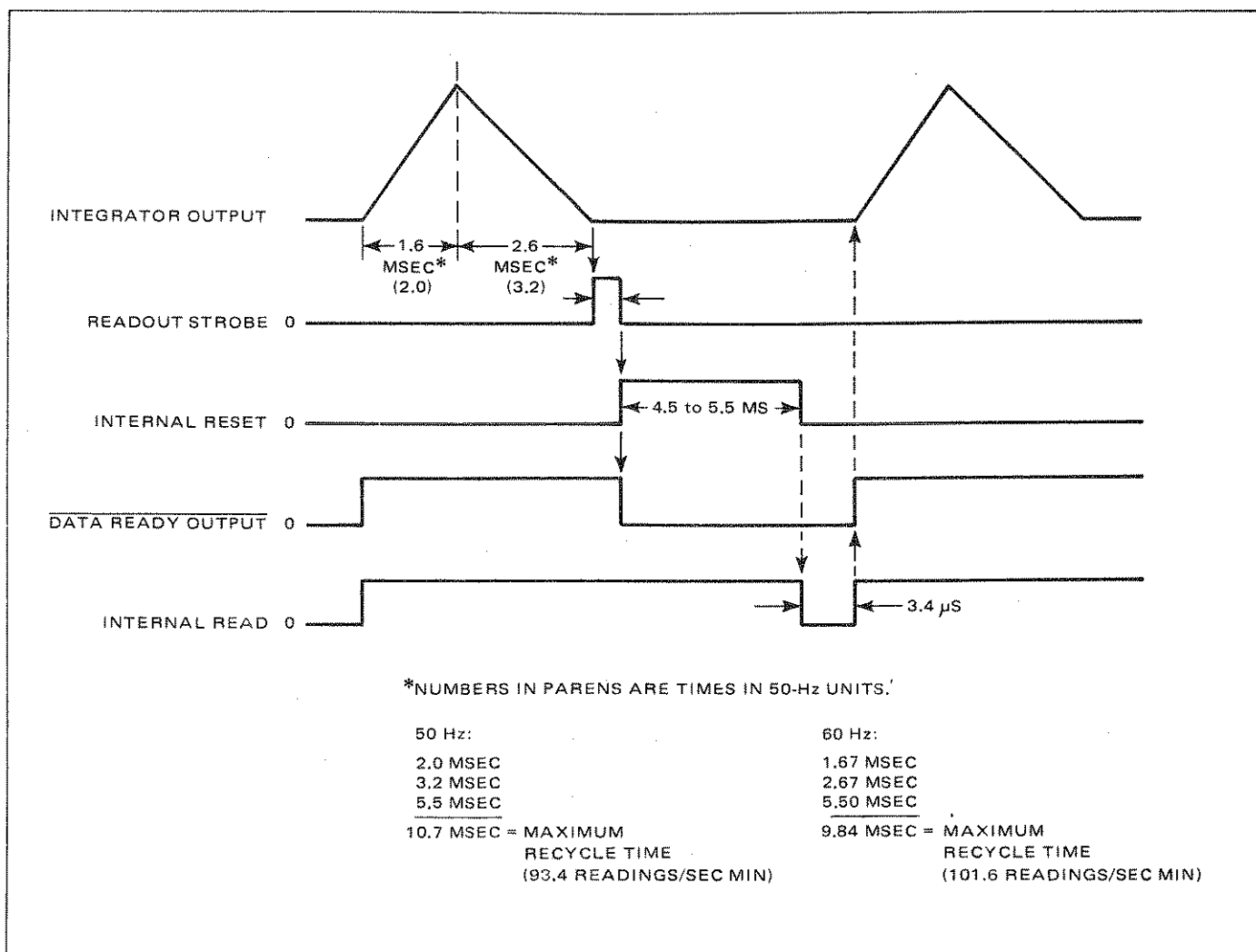

Figure 2.14 - Superfast Read Rate (Worst Case)

increases the minimum reading rate from 20.5 to 102 readings per second (50 Hz: 17.4 to 93 r/s). This is done at the expense of losing the least-significant digit which is reset to zero (blanked out on readout). The signal integration period is reduced from 16-2/3 msec to 1-2/3 msec (50 Hz: 20 msec to 2 msec). This and the resulting reference integrate period reduce the maximum recycle time from 48.8 msec to 9.8 msec (50 Hz: 57.5 msec to 10.7 msec), thereby yielding the 107 reading per second figure (93 r/s with 50 Hz). Timing changes are shown in figure 2.14.

2.70 PRINTER OUTPUT.

2.71 The printer output connector is a double-edged PCB connector (extension of Interconnection and Logic board) with pins A1 through A22 on the bottom edge and pins B1 through B22 on the top edge. Pin assignments are shown in figure 2.15. All outputs are referenced to digital ground pin B1.

2.72 Numerical Data

2.73 Numerical data appears as positive true, four-line BCD code, as shown in figure 2.15. The designator of each line identifies the digit and weight. For example: Pins A18, 19, 20, and 21 are designated 12, 18, 14, and 1, consecutively. The 1 indicates these lines correspond to the units or least significant display; the 2, 8, 4, and 1 subscripts indicate the binary weight of each line.

CAUTION

True output lines are not short-circuit proof. Accidental grounding may damage the output circuitry.

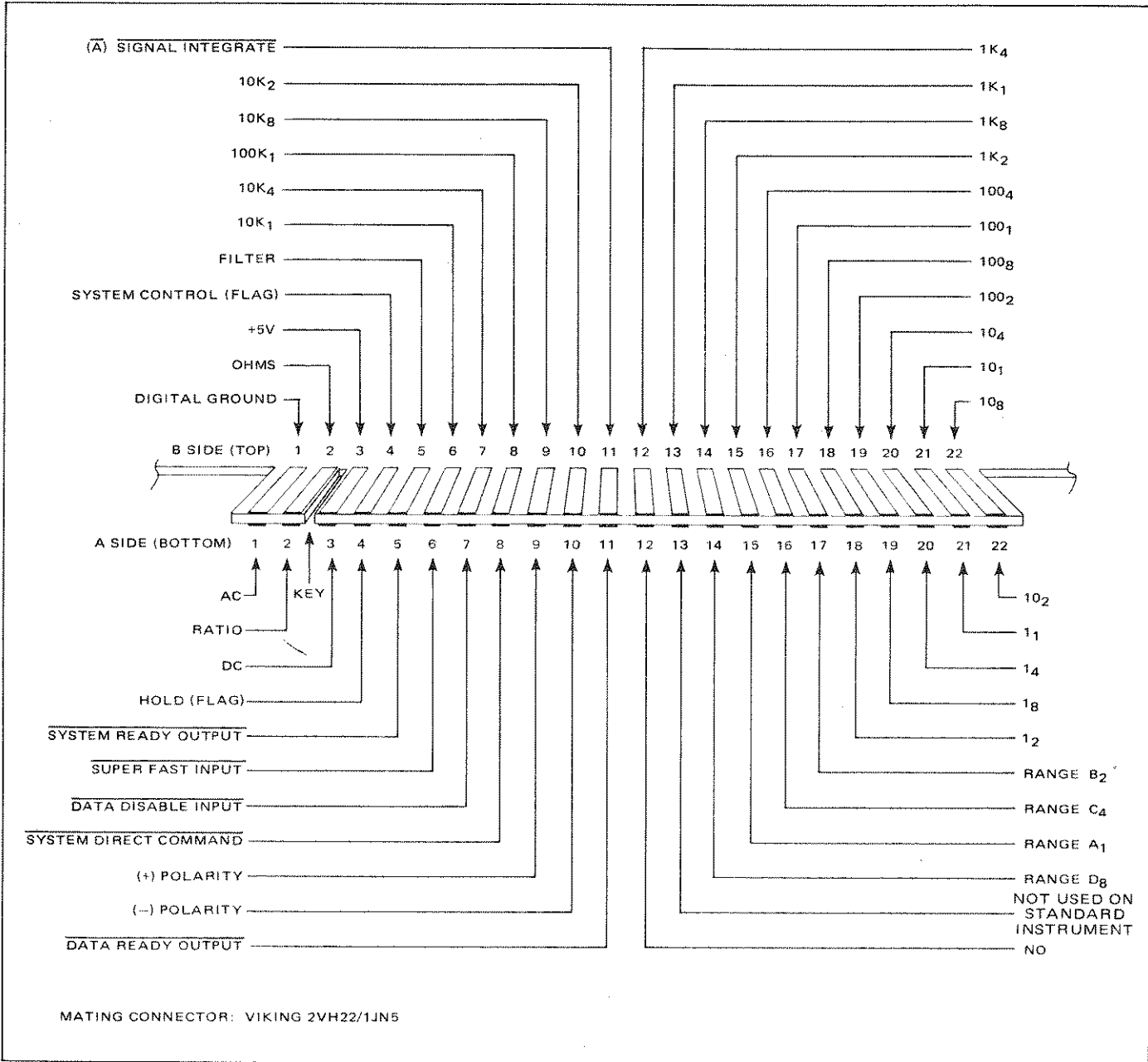

Figure 2.15 - Pin Assignments J201 PRINTER OUT

2.74 Polarity is indicated in positive true format on pin A9 (positive) and pin A10 (negative). The positive polarity line is true when the function output is AC or .1K through 1K OHMS ranges. Negative polarity is true with Ohms on the 10K through 100M ranges. If the instrument overranges, the polarity bit is not updated since no axis-crossing has occurred.

2.75 Function Data.

2.76 Function outputs appear on pins A1, 2, 3 and B2 in their true format. For example: with AC function selected,

AC is true and is indicated by a true level on the corresponding line.

2.77 Range Data.

2.78 Range data appears in four-line BCD code on pins A14 through A17. Range codes are described in table 2.4.

2.79 "NO" Indication.

2.80 The NO line (pin A12) is the same as the NO indicator on the readout. The line is true if a function

Table 2.4 - Range Codes (Printer Output)

Range	A (Pin A15)	B (Pin A17)	C (Pin A16)	D (Pin A14)	Dec Value
10 Ω	0	1	0	0	2
0.1V 0.1 K Ω	1	1	0	0	3
1V 1 K Ω	0	0	1	0	4
10V 10 K Ω	1	0	1	0	5
100V 100 K Ω	0	1	1	0	6
1000V 1000 K Ω	1	1	1	0	7
10 Meg Ω	0	0	0	1	8
100 Meg Ω	1	0	0	1	9

or range is selected for which the particular instrument is not equipped. Overrange is indicated by a true NO line plus a numerical data output of 160000.

2.81 Status Output Lines.

2.82 The following outputs indicate the status of the conversion process within the instrument.

- a. DATA READY. This line (pin A11) remains true during the signal and reference integration periods plus any overrange time, if required. The line drops to the false level to indicate to the printer that the measurement is complete and output data can be printed (Printer Command). With front-panel operation, DATA READY is enabled only when the DATA OUTPUT switch (on front panel) is depressed. Minimum false level time is 4.5 mseconds.
- b. HOLD FLAG. A true level on this line (pin A4) indicates that the instrument is in the Hold mode. A reading can be initiated by one of the following commands:
 1. SYSTEM DIRECT COMMAND (J201-A8)
 2. DIRECT COMMAND (J202-A15)
 3. TIMEOUT COMMAND (J202-B10)
 4. RATE Control (front panel)
- c. SYSTEM READY. This line (pin A5) drops to a false level to indicate that the instrument can now initiate a new reading at the first available read command.

- d. SIGNAL INTEGRATE. This line (pin B11) becomes true at the end of the signal integration period. After this time, the input signals may be changed in preparation for the next reading. The input signal need remain constant only while the instrument is in Signal Integrate, indicated by this line in the false state. For example, the 1-2/3 msec sample time in Superfast could be used in slow sample and hold applications.

2.83 Input Control Lines.

- a. DATA DISABLE. A contact closure to ground or a false logic level applied to this line (pin A7) inhibits the DATA READY output (Print) pulse.
- b. SYSTEM CONTROL. A contact closure to ground or a false logic level on this line (pin B6) disables all front panel operating controls. Operation of the instrument is then under control of the Remote Program input. This command duplicates operation of the PROGRAM CONTROL switch on the front panel. It is necessary that one of these commands be initiated during Autorange to inhibit extra DATA READY pulses.
- c. SUPERFAST. A contact closure to ground or a false logic level applied to this line (J201-A6 or J202-A7) decreases the conversion time of the instrument while sacrificing the least-significant digit. This mode is described in paragraph 2.68. Because of the superfast read rate, do not use this mode with Autorange.

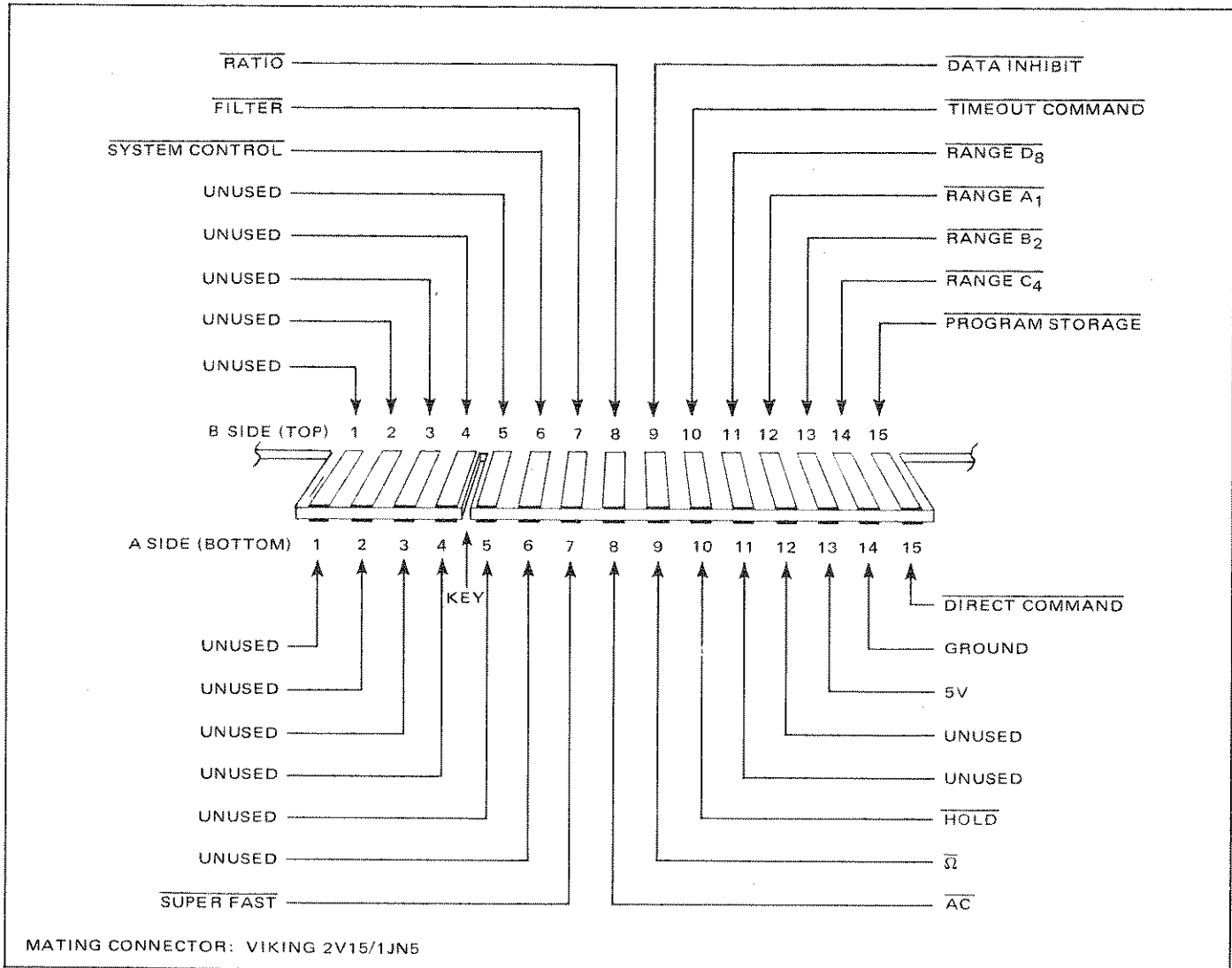

Figure 2.16 - Pin Assignments J202 PROGRAM INPUT

2.84 SYSTEM DIRECT COMMAND.

2.85 To externally initiate a measurement with this command, the instrument must be in the Hold mode. Then, a contact closure to ground or a false logic level to this line (pin A8) generates a read command. Minimum false level time is $3.4 \mu\text{sec}$. Continuous readings at the maximum read rate are obtained by tying this line to ground. Read commands delayed by $5 \text{ msec} \pm 10\%$ (for settling time) are then generated automatically.

2.86 REMOTE PROGRAMMING.

2.87 The instrument accepts commands made through PROGRAM INPUT connector J202 on the rear panel. Pin assignments of J202 are shown in figure 2.16. Commands

are made by a switch closure from the appropriate pin to ground or by standard TTL logic levels as described earlier.

2.88 SYSTEM CONTROL.

2.89 A contact closure to ground or a false logic level applied to pin B6 disables all front panel operating controls. Operation of the instrument is then under control of the remote program input. This line duplicates the PROGRAM CONTROL switch on the front panel.

2.90 Function Programming.

2.91 The desired function is selected by applying a ground or false logic level to the appropriate pin (table 2.5).

Table 2.5 - Function Programming

\overline{DC}	NC
\overline{AC}	pin A8
\overline{OHMS}	pin A9
\overline{RATIO}	pin B8
\overline{FILTER}	pin B7

2.92 The 5 msecond internal delay is not adequate for settling time on the 100 VDC, 1000 Kilohm, 10 Megohm, 100 Megohm, and all AC ranges. Therefore, the timeout command, providing timeout delays listed in table 2.7, must be used to initiate readings on these ranges unless the input is fixed with range and function predetermined.

2.93 Range Programming.

2.94 Range programming is selected by applying false logic levels in BCD code to the four range lines described in table 2.6 below. With no lines programmed, Autorange is automatically selected.

2.95 + Five Volts.

2.96 This voltage, +5 volts \pm 5%, from the logic power supply is available at pin A13 for external use. Current output is .1A, maximum.

2.97 Hold.

2.98 The Hold line parallels the operation of the ccw position of the front panel RATE potentiometer and is selected by a contact closure or a false logic level on pin A10. Hold is required when using either of the three read commands.

2.99 Read Commands.

2.100 Either of two read command lines can be selected by a contact closure to ground or by a negative logic level applied to the appropriate pin. Pin A15, $\overline{DIRECT COMMAND}$, commands a new measurement if applied after a five millisecond reset delay, and if the command is present for 3.4 μ seconds. Pin B10, $\overline{TIMEOUT COMMAND}$, starts a new measurement after five milliseconds plus a timeout delay to allow for internal settling time of the measured signal. $\overline{TIMEOUT COMMAND}$ may be commanded before the previous 5 msec delay since the timeout generator stores the reading.

2.101 Timeouts.

2.102 Timeout periods for each function are listed in table 2.7. In Autorange, the indicated delays are taken following each range change.

2.103 Data Inhibit.

2.104 A contact closure or false logic level on pin B9 inhibits $\overline{DATA READY OUTPUT}$ (Print pulse) from being generated.

2.105 Program Storage.

2.106 A false level (equivalent to three TTL inputs) on pin B15 will store all the programmed inputs except the Direct and Timeout commands as they existed on the negative edge of this command (see diagram below).

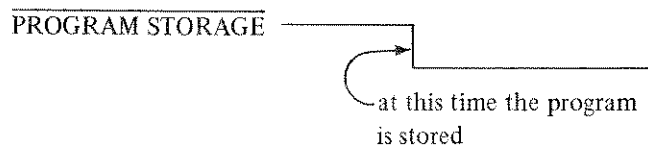

Table 2.6 - Range Codes (Programmer)

Range	\overline{A} (Pin B12)	\overline{B} (Pin B13)	\overline{C} (Pin B14)	\overline{D} (Pin B11)	Dec Value
AUTO	1	1	1	1	0
10 Ω	1	0	1	1	2
0.1V 0.1 K Ω	0	0	1	1	3
1V 1 K Ω	1	1	0	1	4
10V 10 K Ω	0	1	0	1	5
100V 100 K Ω	1	0	0	1	6
1000V 1000 K Ω	0	0	0	1	7
10 Meg Ω	1	1	1	0	8
100 Meg Ω	0	1	1	0	9

2.107 SUPERFAST.

2.108 A contact closure to ground or a false logic level applied to pin A7 decreases the signal integrate and the reference integrate times (see paragraph 2.68). This provides the maximum reading rate in the **Direct COMMAND** mode of operation. Because of the high reading rate, Superfast must be programmed with a fixed range rather than **UTORANGE**.

Table 2.7 - Timeouts

DC	30 msec
1 Ohm to 1 Megohm	30 msec
10 Meg*	30 msec
100 Megohm	300 msec
Filter	470 msec (plus function timeout)
AC(fixed range,no filter)	180 msec
AC+Filter(&Autorange)	650 msec

*Use filter for <.01% error

Table 2.8 - Maximum Input Voltage

CAUTION

Do not exceed the following maximum inputs.

DC	1000 VDC or RMS AC All ranges
AC	1000 RMS to 20 kHz decreasing 20 dB/decade to 20V RMS at 1 MHz
RATIO	Input: same as function selected Reference: +10.5V, -0.5V
OHMS	±500V DC or Peak AC
GUARD	Voltage between GUARD AND - INPUT must not exceed 250 volts or damage to the instrument may result

2.109 ADDING/REMOVING ACCESSORIES.

2.110 The AC and Ohms options may be added or removed at any time in the field without modification to the

basic instrument. Note that the switching board (403625) is required whenever the plug-in options are used. Access to the mounting connectors is by removal of the top cover, held down by captive screws in each of the four corners, and by removal of shield, mounted by four flat head screws.

2.111 When an option is added or removed from the instrument, a jumper corresponding to the option is removed or added to allow proper operation of the NO circuitry. The two jumpers (W1 Ohms and W2 AC) are located on the display board, shown partially in figure 2.17. When an option is added, the corresponding jumper is added; conversely, when an accessory is removed, the jumper is removed.

2.112 The AC RMS (Option 32) allows for either AC or DC coupled measurements. The selector switches are located on the AC RMS converter as shown in figure 5.8.

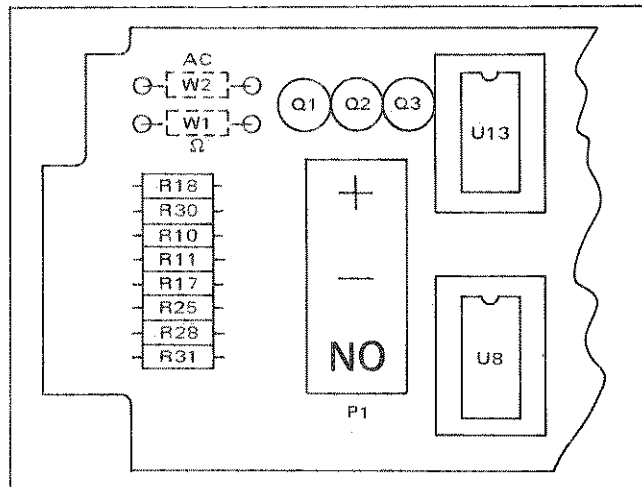

Figure 2.17 - Jumper Location

2.113 MODEL 55 GENERAL PURPOSE INTERFACE BUS.

2.114 The Model 5900 DMM may be interfaced with other instrumentation and control devices through use of the Model 55 General Purpose Interface Bus (GPIB). Information and the specifications for the GPIB are presented in paragraph 1.19 and Table 1.2 in Section 1 of this manual.

2.115 The programming information and detailed electrical interface connection information is presented in the Model 55 Instruction Manual, Dana Document Number 980498.

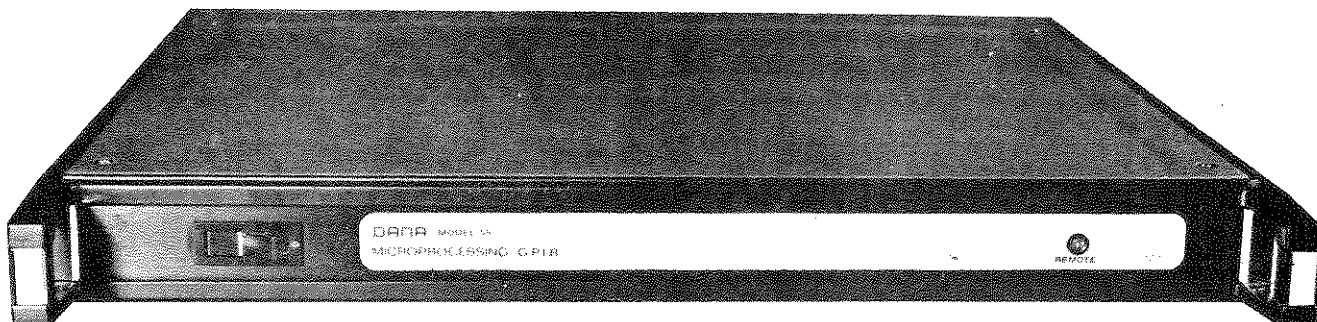

Figure 2.18 - Model 55 General Purpose Interface Bus

2
2
a
re
vi
m
fa
A
A
2
2
n
2

SECTION 3

SPECIFICATION TESTS

3.1 GENERAL.

3.2 This section contains procedures that compare the operation of the instrument against the published specifications found at the front of this manual. It is intended to be used for incoming inspection and as a periodic check to determine if recalibration of the instrument is warranted.

3.3 The procedures provide sufficient checks to verify proper operation and that the instrument is within the 90 day accuracy limits. Covers of the instrument are not removed for any of the tests. The required ambient temperature of the environment is $23^{\circ} \pm 5^{\circ}\text{C}$.

3.4 REQUIRED EQUIPMENT.

3.5 In Table 3.1 is a list of equipment necessary for checking the instrument. The equipment in this table, with

the exception of those in the OTHER category, is the same as required for recalibration and is explained in detail in Section 5.

3.6 PROCEDURE.

3.7 Allow one hour for warmup. Convert the instrument and the test equipment as shown in the figure supplied with each accuracy check. Select the controls and inputs as called out in the tables and monitor the instrument readout for the indicated values. If the instrument is equipped with the rear panel selectable input option, set the FRONT/REAR switch to the FRONT position for all procedures presented in this section.

Table 3.1 - Required Equipment

Function	Qty	Item	Minimum Use Specifications	Suggested Equipment
DC	(1)	Saturated Standard Cell Bank (6 cells)	1 ppm, certified	EPPLEY 106
	(2)	DC Voltages Sources	0.1 ppm resolution	FLUKE 332B
	(2)	Voltage Dividers, Adjustable	0.1 ppm linearity	FLUKE 720A
	(2)	Null Detector/ μ Voltmeters	1 μ V sensitivity	FLUKE 845AR
AC	(1)	Thermal Transfer Standard	50 ppm	HOLT 6A, With corrections
	(1)	AC Voltage Source	1 ppm resolution	HP745A/746A
Ω	(8)	Resistance Standards		
		10 Ω	10 ppm	ESI SR1 with corrections
		100 Ω	5 ppm	ESI SR1 with corrections
		1 K Ω	5 ppm	ESI SR1 with corrections
		10 K Ω	5 ppm	ESI SR1 with corrections
		100 K Ω	5 ppm	ESI SR1 with corrections
		1 M Ω	5 ppm	Fabricated
		10 M Ω	20 ppm	ESI SR1 with corrections
100 M Ω	80 ppm	Fabricated		
OTHER	(1)	Momentary Switch, SPST	—	—
	(2)	1.5 volt cells w/screwtype binding posts	—	—
	(1)	Insulated Adjustment tool	—	JFD5284
	(1)	100 Ω , 10, 100 Kilohm, 1 Megohm 1/4 Watt 5% Carbon Resistors	5%	—
	(1)	1 μ FD non polar capacitor	—	—

Table 3.2 - DC Range Check (Low Ranges)

DVM		INPUT SIGNAL		NOMINAL READING	TOLERANCE	NOTE
FUNCTION	RANGE	DC VOLTAGE STANDARD	DIVIDER SETTING			
DC	.1V	10.00000	.01000	.100000	.099992 - .100008	23°C ± 5°C (After zeroing)
	1V	10.00000	.10000	1.00000	0.99997 - 1.00003	

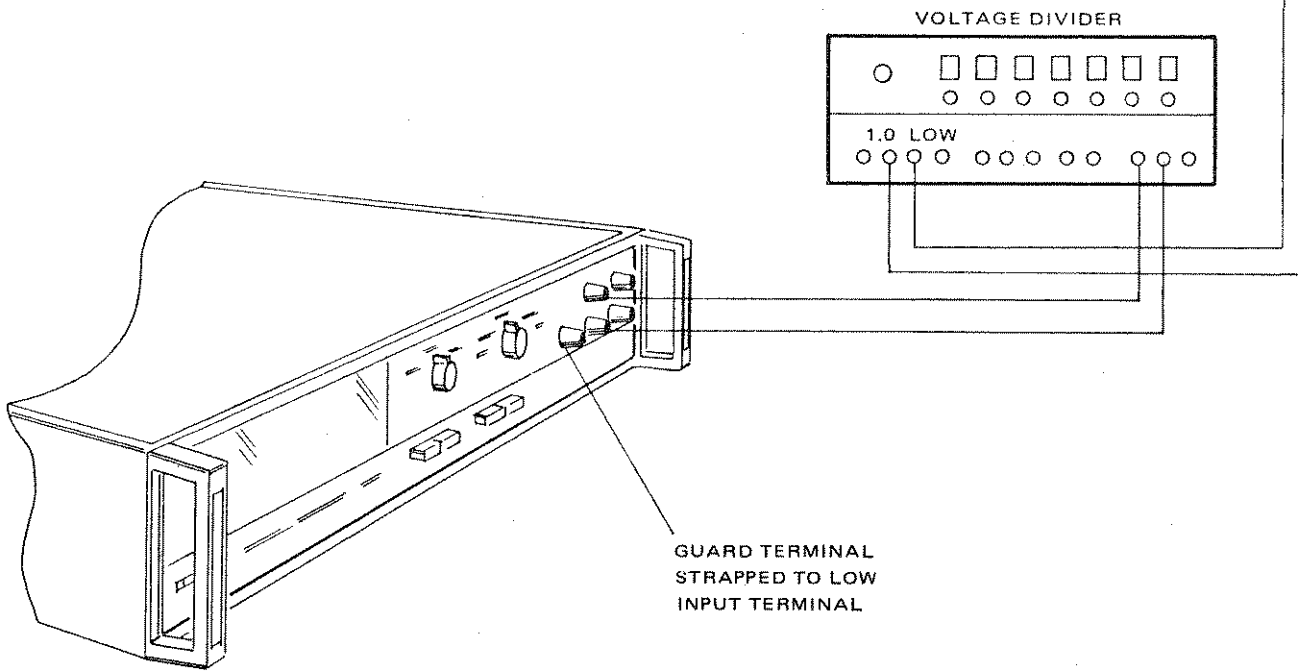
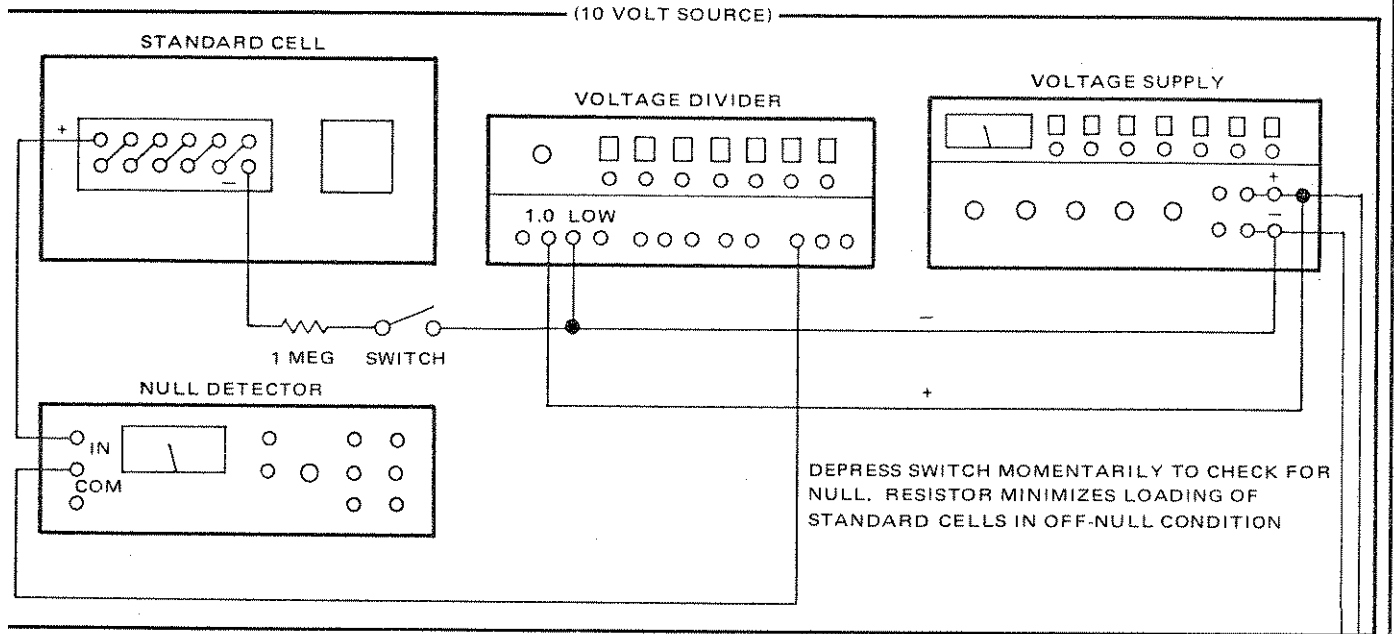

Table 3.3 - DC Range Check (High Ranges)

DVM		INPUT SIGNAL		NOMINAL READING	TOLERANCE	NOTE
FUNCTION	RANGE	DC VOLTAGE STANDARD				
DC	10	10.0000V		10.0000	9.9998 – 10.0002	23°C ± 5°C (After zeroing)
	100	100.000V		100.000	99.997 – 100.003	
	1000	1000.00V		1000.00	999.97 – 1000.03	

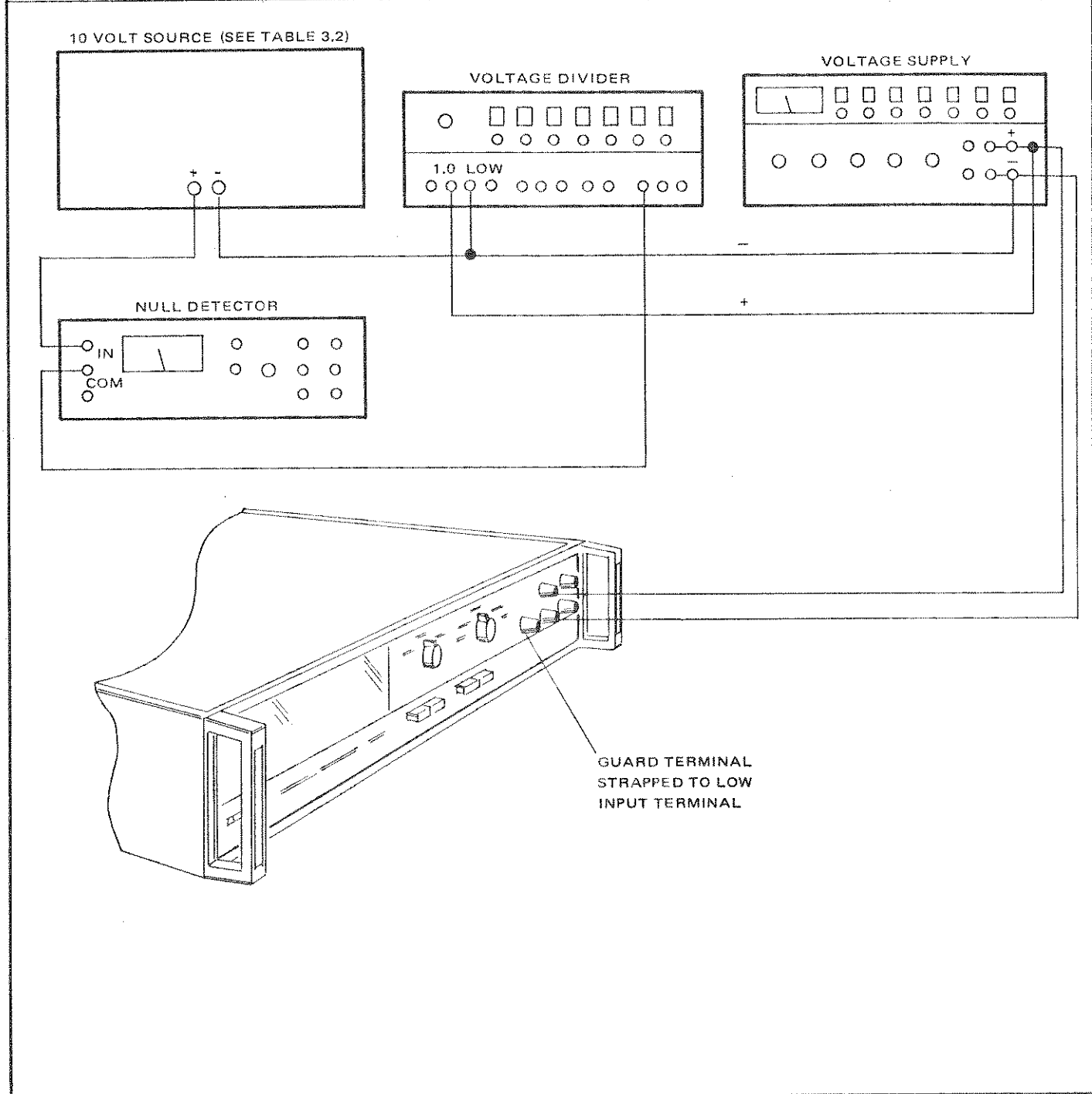

Table 3.4 - 3-Wire Ratio Check

DVM		INPUT SIGNAL		NOMINAL READING	TOLERANCE	NOTE
FUNCTION	RANGE	DC VOLTAGE STANDARD				
DC RATIO	10	+ 2.00000V		10.0000	9.9990 - 10.0010	23°C ± 5°C (After zeroing)
		+10.00000V		10.0000	9.9998 - 10.0002	

DC VOLTAGE STANDARD

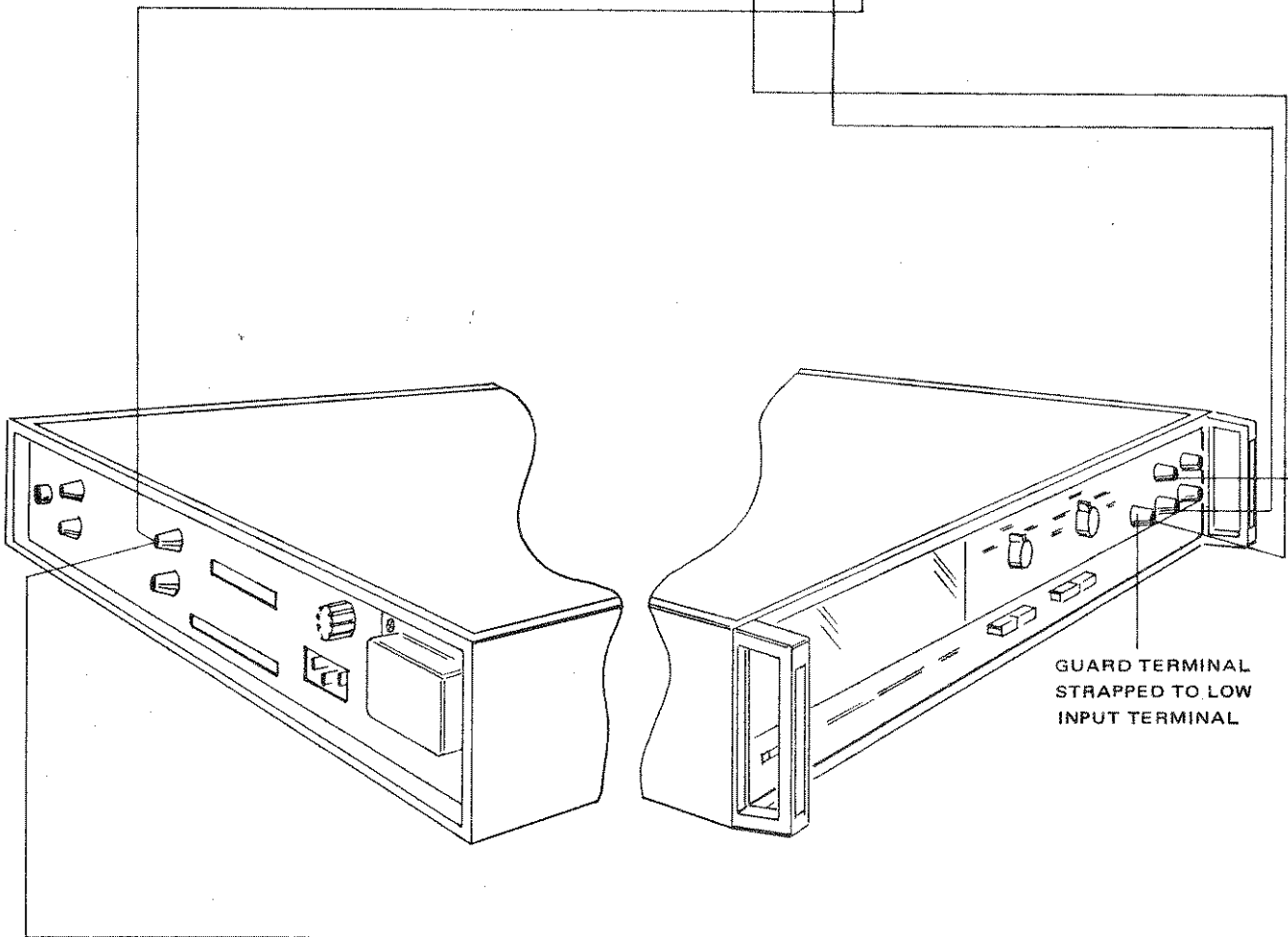
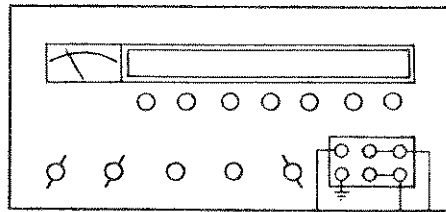

Table 3.5 - 4-Wire Ratio Check

DVM		INPUT SIGNAL		NOMINAL READING	TOLERANCE	NOTE
FUNCTION	RANGE	DC VOLTAGE STANDARD				
DC RATIO	10	+ 2.00000V		+10.0000	9.9980 - 10.0020	23°C ± 5°C (After zeroing)
	10	+10.00000V		+10.0000	9.9996 - 10.0004	
		-10.00000V		+10.0000	9.9996 - 10.0004	

DC VOLTAGE STANDARD

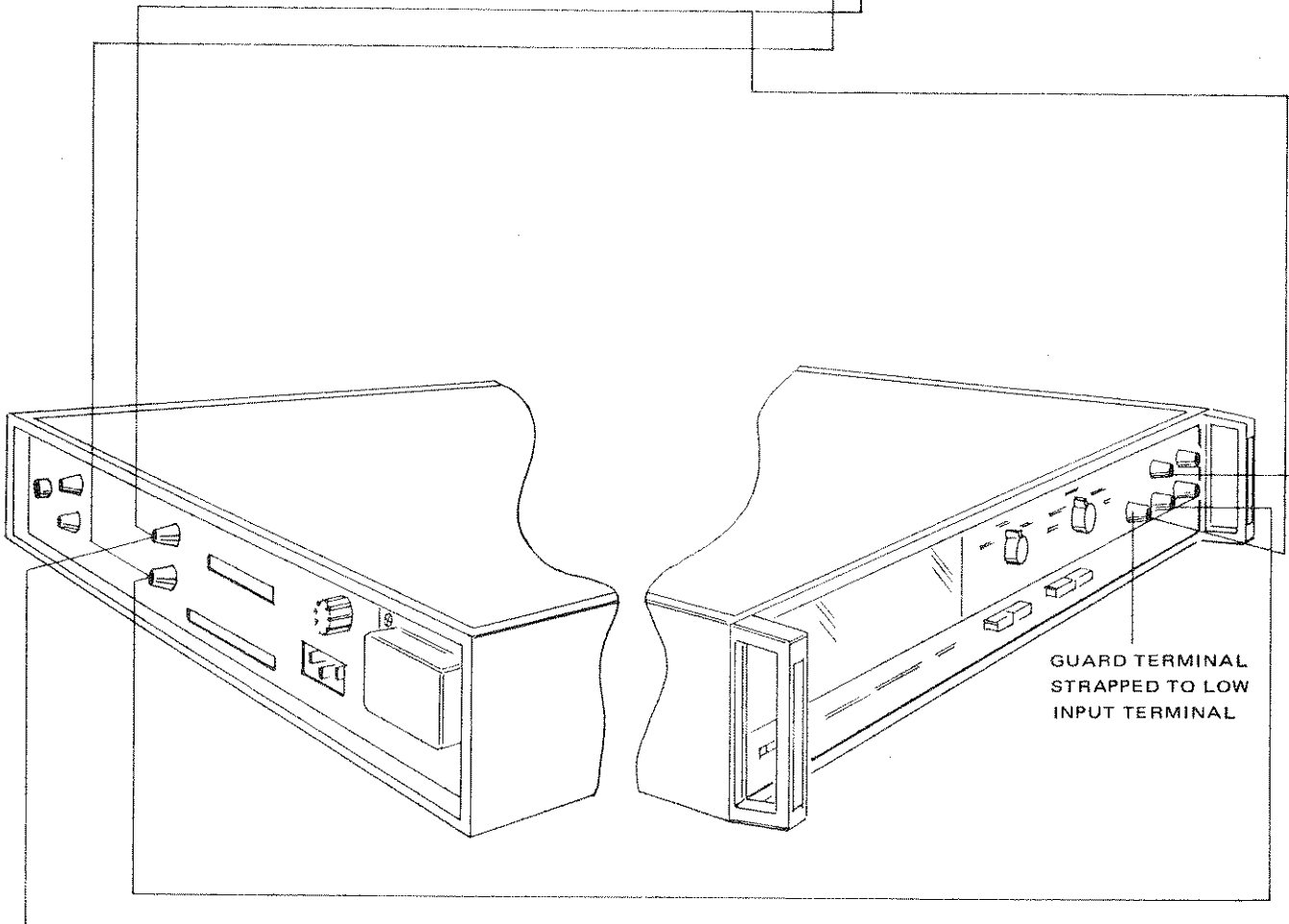
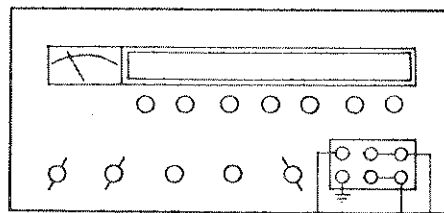

Table 3.6 - DC Input Resistance

DVM		INPUT SIGNAL		DVM DISPLAY	TOLERANCE*	NOTE
FUNCTION	RANGE	DC VOLTS*	S1			
DC (Filter In)	0.1	.100000	Closed	.100000		R _s
			Open		.099989 - .100001	1 Meg
	1	1.000000	Closed	1.00000		
			Open		0.99989 - 1.00001	1 Meg
	10	10.00000	Closed	10.0000		
			Open		9.9989 - 10.0001	1 Meg
	100	100.0000	Closed	100.000		
			Open		99.989 - 100.001	1 K
	1000	1000.000	Closed	1000.00		
			Open		999.89 - 1000.01	1 K
						*Adjust the DC Voltage Standard to produce the DVM DISPLAY reading.

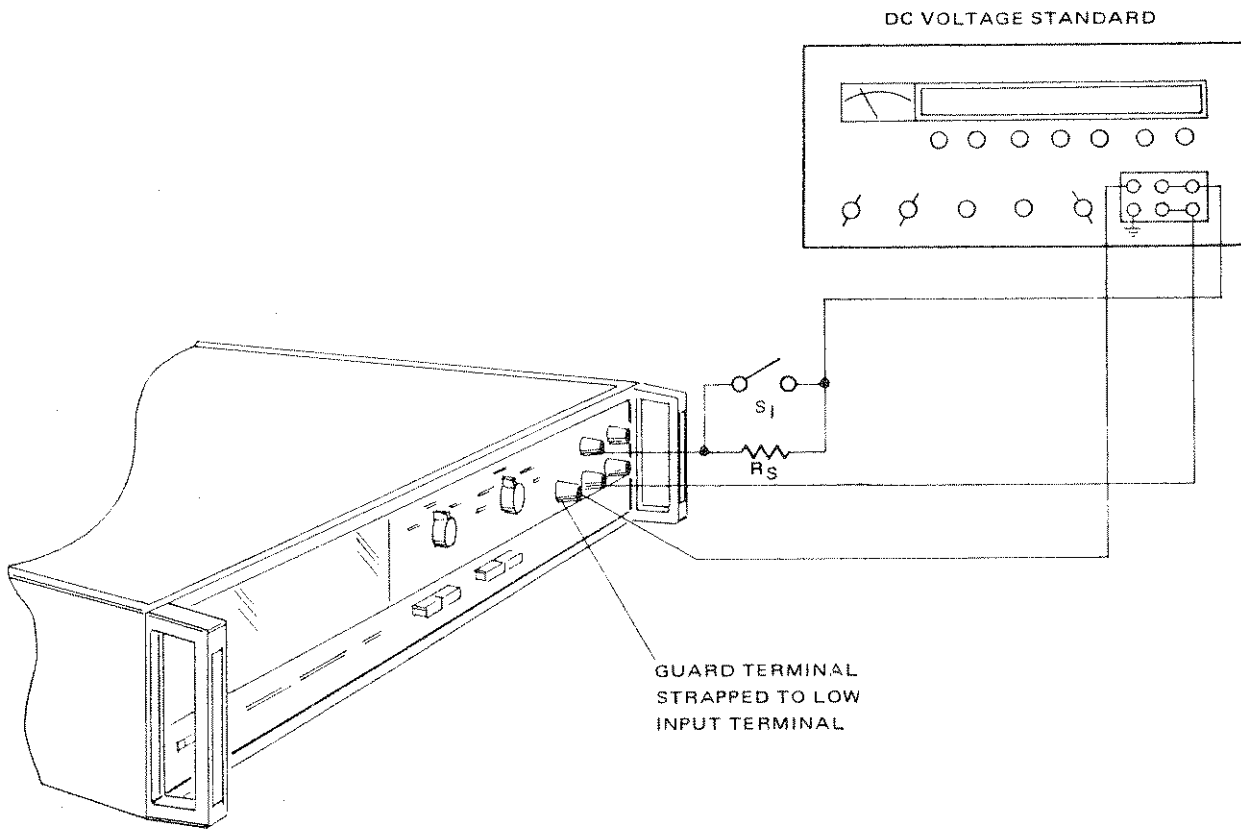
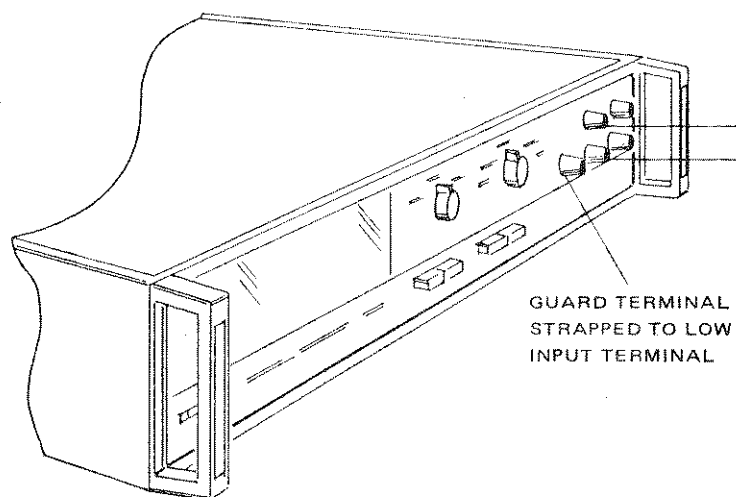
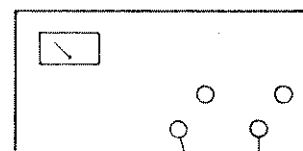
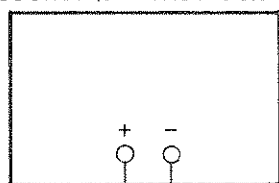

Table 3.7 - Model 33 AC Converter Range Check

DVM		INPUT SIGNAL		NOMINAL READING	TOLERANCE	NOTE
FUNCTION	RANGE	DC VOLTAGE STANDARD	AC			
AC	1	1.000000	1V @ 400 Hz	1.00000	0.99968 – 1.00032	Refer to figure 5.3 for additional information on use of AC source equipment
		1.000000	1V @ 50 kHz	1.00000	0.99945 – 1.00055	
	10	10.00000	10V @ 400 Hz	10.0000	9.9968 – 10.0032	
		10.00000	10V @ 50 kHz	10.0000	9.9945 – 10.0055	
	100	100.0000	100V @ 400 Hz	100.000	99.968 – 100.032	
		100.0000	100V @ 50 kHz	100.000	99.945 – 100.055	
	1000	1000.000	1000V @ 400 Hz	1000.00	999.48 – 1000.52	
		500.00	500V @ 50 kHz	500.00	499.70 – 500.30	

DC SOURCE (SEE TABLES 3.2 & 3.3)

AC LABORATORY POWER SOURCE



THERMAL TRANSFER VOLTMETER

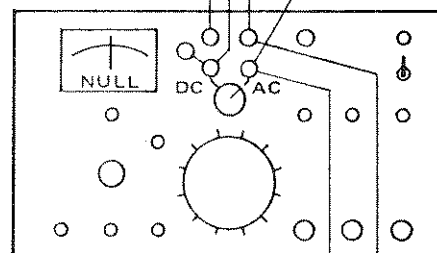

Table 3.8 - Model 32 AC Converter Range Check

DVM		INPUT SIGNAL		NOMINAL READING	TOLERANCE	NOTE
FUNCTION	RANGE	DC VOLTAGE STANDARD	AC			
AC	1	1.000000	1V @ 400 Hz	1.00000	0.99910 - 1.00090	Same as table 3.7
		1.000000	1V @ 50 kHz	1.00000	.99800 - 1.00200	
	10	10.00000	10V @ 400 Hz	10.0000	9.9910 - 10.0090	
		10.00000	10V @ 50 kHz	10.0000	9.9800 - 10.0200	
	100	100.0000	100V @ 400 Hz	100.000	99.910 - 100.090	
		100.0000	100V @ 50 kHz	100.000	99.800 - 100.200	
	1000	1000.000	1000V @ 400 Hz	1000.00	998.80 - 1001.20	
		500.000	500V @ 50 kHz	500.00	498.50 - 501.50	

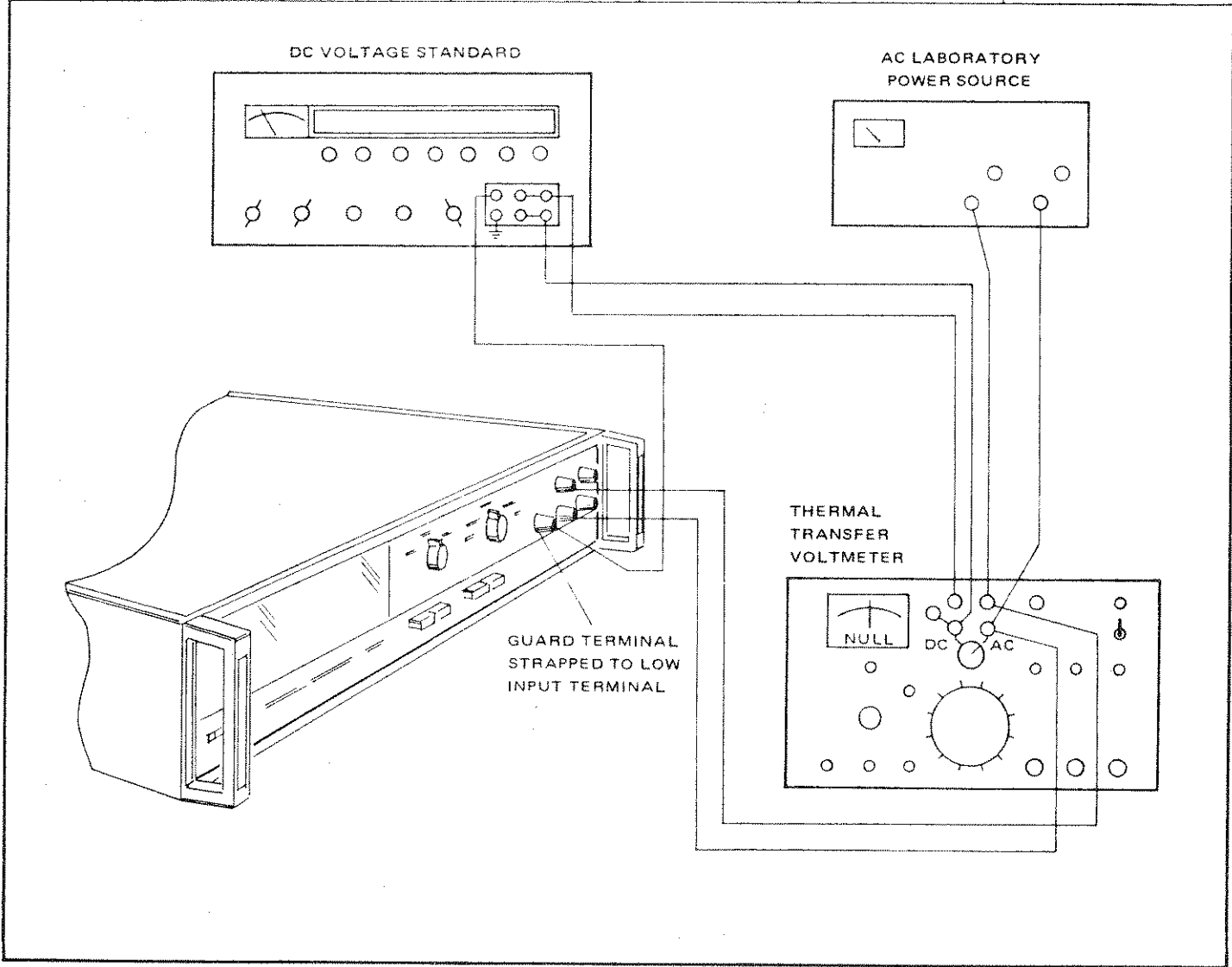

Table 3.9 - Ohms-Megohms Range Check

DVM		INPUT SIGNAL		NOMINAL READING (Same as Standard)	TOLERANCE
FUNCTION	RANGE	NOMINAL STANDARD VALUE	TOLERANCE		
$\Omega - M\Omega$	10 Ω	10 Ω	.001%		± 10 digits
	100 Ω	100 Ω	.0005%		± 4 digits
	1 k Ω	1 k Ω	.0005%		± 4 digits
	10 k Ω	10 k Ω	.0005%		± 4 digits
	100 k Ω	100 k Ω	.0005%		± 4 digits
	1 M Ω	1 M Ω	.0005%		± 4 digits
	10 M Ω	10 M Ω	.002%		± 31 digits
	100 M Ω	100 M Ω	.01%		± 51 digits

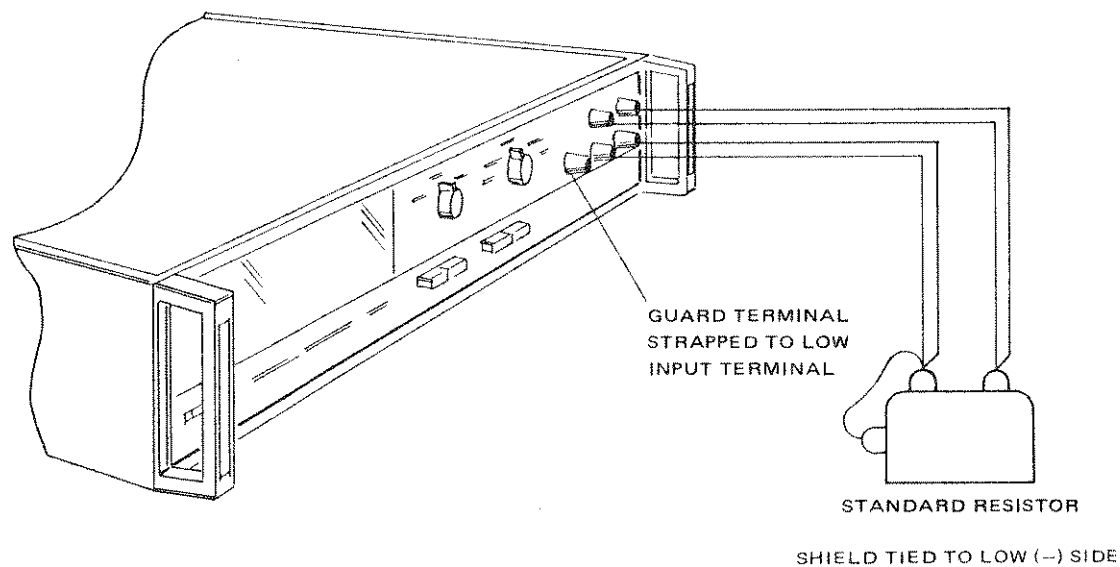

Table 3.10 - Common Mode Rejection (In DC Volts Function)

DVM		INPUT SIGNAL		NOMINAL READING See Note 1	TOLERANCE	NOTE
FUNCTION	RANGE	S1				
DCV FILT. OUT	0.1	Off			±1 digit from nominal	1) With switch S-1 in the off position, record the reading displayed on the DMM's readout in the "nominal reading" boxes of the table.
		DC			±5 digits from nominal	
		AC			±25 digits from nominal	
DCV FILT. IN	0.1	DC			±50 digits from nominal	
		AC			±25 digits from nominal	

NOTE: THE TWO BACK TO BACK 1.5V BATTERIES PROVIDE A SMALL INPUT SIGNAL OF SEVERAL MILLIVOLTS TO OFFSET THE READING FROM ZERO (SINCE NO TWO SUCH BATTERIES ARE EQUAL IN VOLTAGE). THIS AVOIDS POLARITY CHANGES DURING CMR TESTS WHICH MAY MAKE THE READING HARD TO INTERPRET.

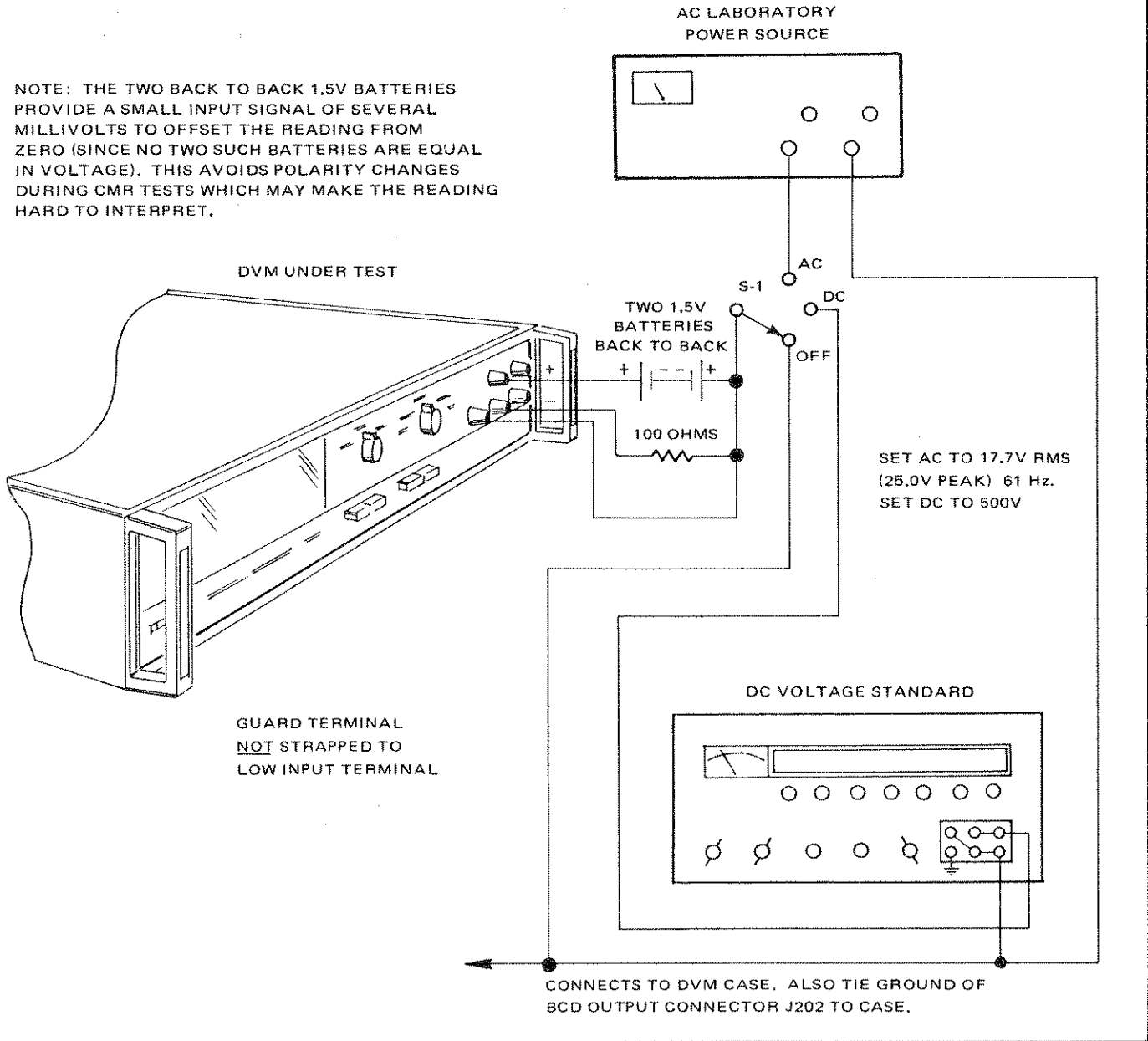

Table 3.11 - Normal Mode Noise Rejection (In DC Volts Function)

DVM		INPUT SIGNAL		NOMINAL READING	TOLERANCE	NOTE
FUNCTION	RANGE	DC	AC			
DC FILT. OUT	10	0.5V	10V*, 60 Hz†	00.5000	±400 digits	
FILT. IN	1V	0.5V	2V*, 60 Hz†	0.50000	± 2 digits	

*peak

†50 Hz (Option 04)

Note: The 60 Hz source must be 60 Hz within .1 Hz

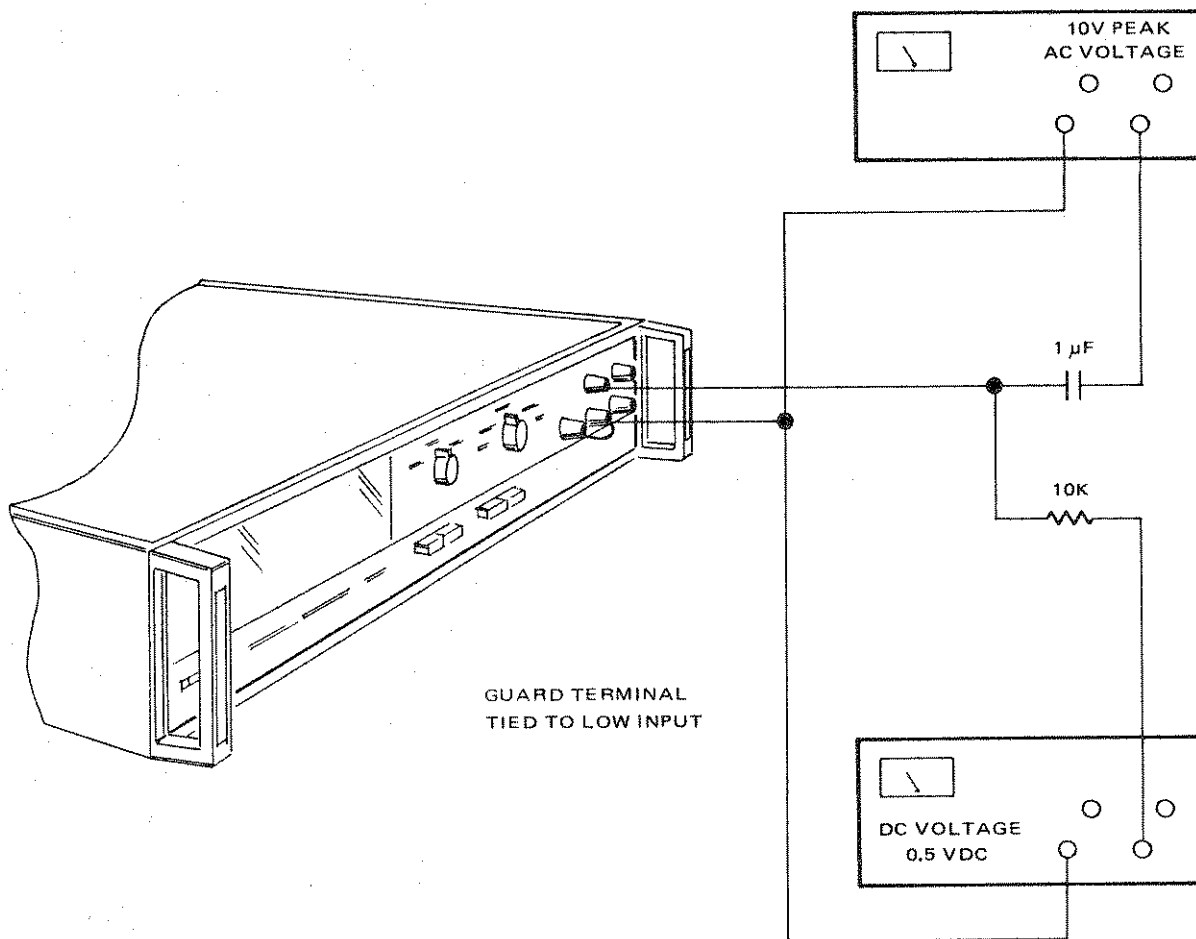
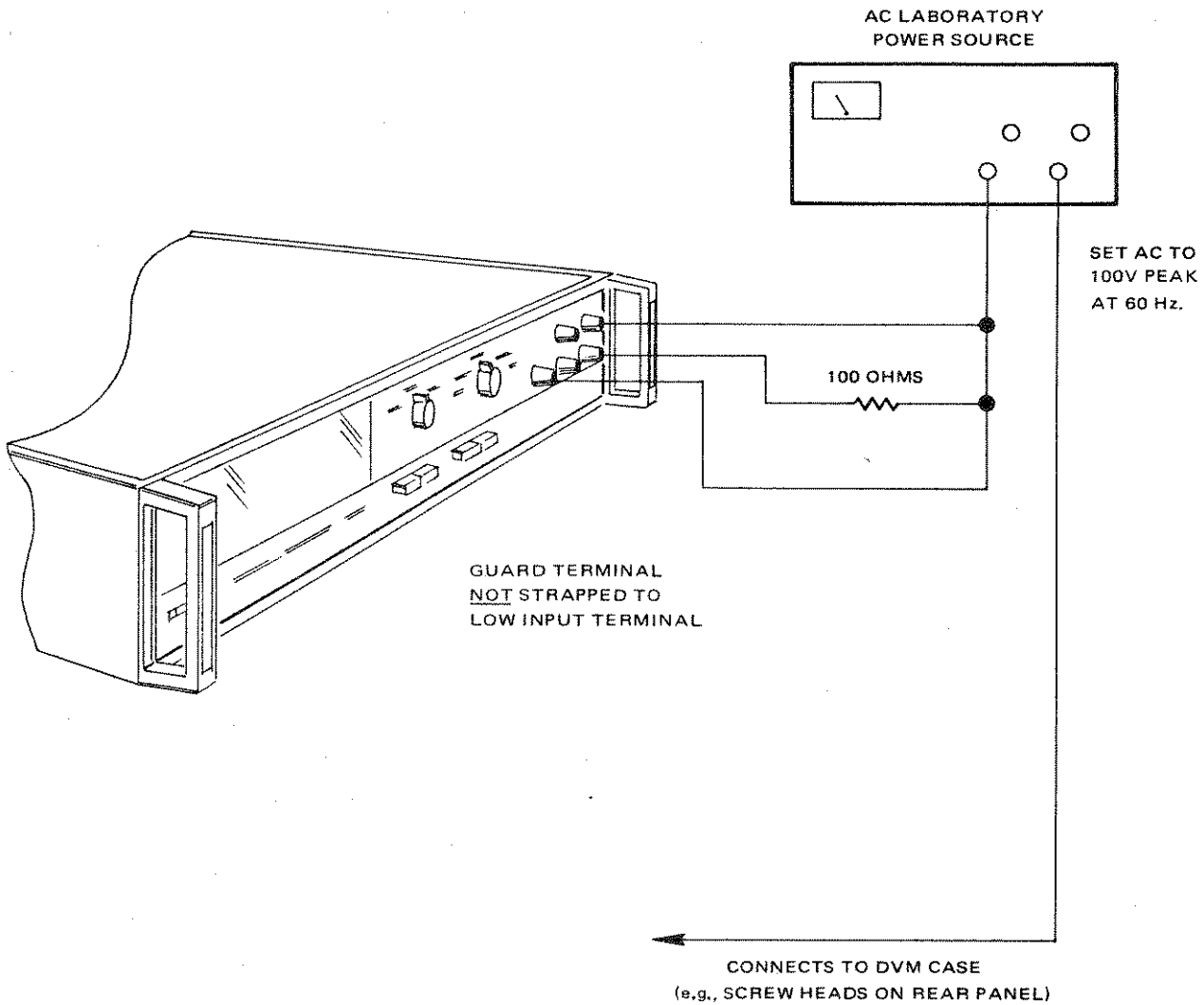

Table 3.12 - Common Mode Rejection (In AC Volts Function)

DVM		COMMON MODE INPUT SIGNAL		NOMINAL READING (see note)	TOLERANCE	NOTE
FUNCTION	RANGE	VOLTAGE	FREQ.			
AC	1	100V Peak	60 Hz		±10 digits	Enter reading with shorted input in nominal column before beginning
	10	100V Peak	60 Hz		±1 digit	
	100	100V Peak	60 Hz		±1 digit	
	1000	100V Peak	60 Hz		±1 digit	



SECTION 4

THEORY OF OPERATION

4.1 GENERAL.

4.2 This section describes the operation of the main circuitry of the Model 5900 DVM, briefly covering the mechanical organization and then the electrical operation of the instrument. The simplified drawings provided in this section are for the purpose of illustration, and supplement the complete schematics of Section 6.

4.3 MECHANICAL DESCRIPTION.

4.4 The Model 5900, shown in figure 4.1, consists of a large, single, printed circuit Logic and Interconnection board (Main Logic) with as many as 12 separate PC boards plugging directly or indirectly (by means of cables) into the Main Logic board. The electronics are housed in a sturdy die cast and stamped aluminum package with the readout, input terminals, and all manual controls located on the front panel. On the back panel is located the power cable input, all data output, optional remote input, analog output, external reference, and optional rear inputs.

4.5 ELECTRICAL DESCRIPTION.

4.6 The instrument is divided into three functional groups. These are the Signal Conditioning section, the Analog-to-Digital Conversion section, and the Display/Control Logic section.

4.7 SIGNAL CONDITIONING SECTION.

4.8 The Signal Conditioning section for a fully equipped instrument consists of: the Switching Board, the Ohms Converter, the Averaging AC Converter or the RMS AC Converter, the Attenuator, and the Isolator. The basic instrument consists of the Switching Bypass Board, the Attenuator, and the Isolator.

4.9 The Signal Conditioning section routes, scales, filters and, when required, converts the input signal into a stable 10 volt full scale dc level for use by the measurement portion of the DVM.

4.10 Switching Board.

4.11 The Switching board is a single printed circuit board and occupies connectors J5 and J6 on the Main Logic board. The Switching board is used with instruments equipped with either the Ohms Converter or either of the available ac converters and is necessary for the generation and isolation of range data and for signal routing required

by the options. The interconnection of the Switching board with the options and the other components of the Signal Conditioning section is shown in block diagram form in figure 4.2.

4.12 The control of signal flow through the Switching board, shown in simplified form in figure 4.3, is by means of two relays K1 and K2. The three possible signal routes provided by the board are illustrated in figure 4.4. Referring to this figure, with the dc function selected, neither of the relays is energized and the signal flow is as shown in (a); with the ac function selected, relay K1 is energized and the signal flow is as shown in (b); with ohms function selected, relay K2 is energized and the signal flow is as shown in (c).

4.13 The range control of the option boards uses analog supply voltages and require isolation from the digital supplies and decoding. This is provided on the Switching board by three Optically Coupled Isolators (OCI) and a BCD to TEN line driver. The decoding of the range logic is given in table 4.1.

Table 4.1 - Switching Board Range Decode

INPUT CODE			WEIGHT	OUTPUT CODE							
RANGE				U2 PIN NO.							RANGE
A ₁	B ₂	C ₄		8	9	13	14	11	10	16	
L	H	L	2	L	H	H	H	H	H	H	.01
H	H	L	3	H	L	H	H	H	H	H	.1
L	L	H	4	H	H	L	H	H	H	H	1
H	L	H	5	H	H	H	L	H	H	H	10
L	H	H	6	H	H	H	H	L	H	H	100
H	H	H	7	H	H	H	H	H	L	H	1000
L	L	L	0	H	H	H	H	H	H	L	10,000

4.14 Ohms Converter.

4.15 The Ohms Converter circuitry is mounted on a single printed circuit board and occupies connector J10 on the Main Logic board. The circuitry, shown simplified in figure 4.5, consists of a high gain amplifier and a relay operated positive current source that is capable of producing any one of eight precise current levels depending on the range selected.

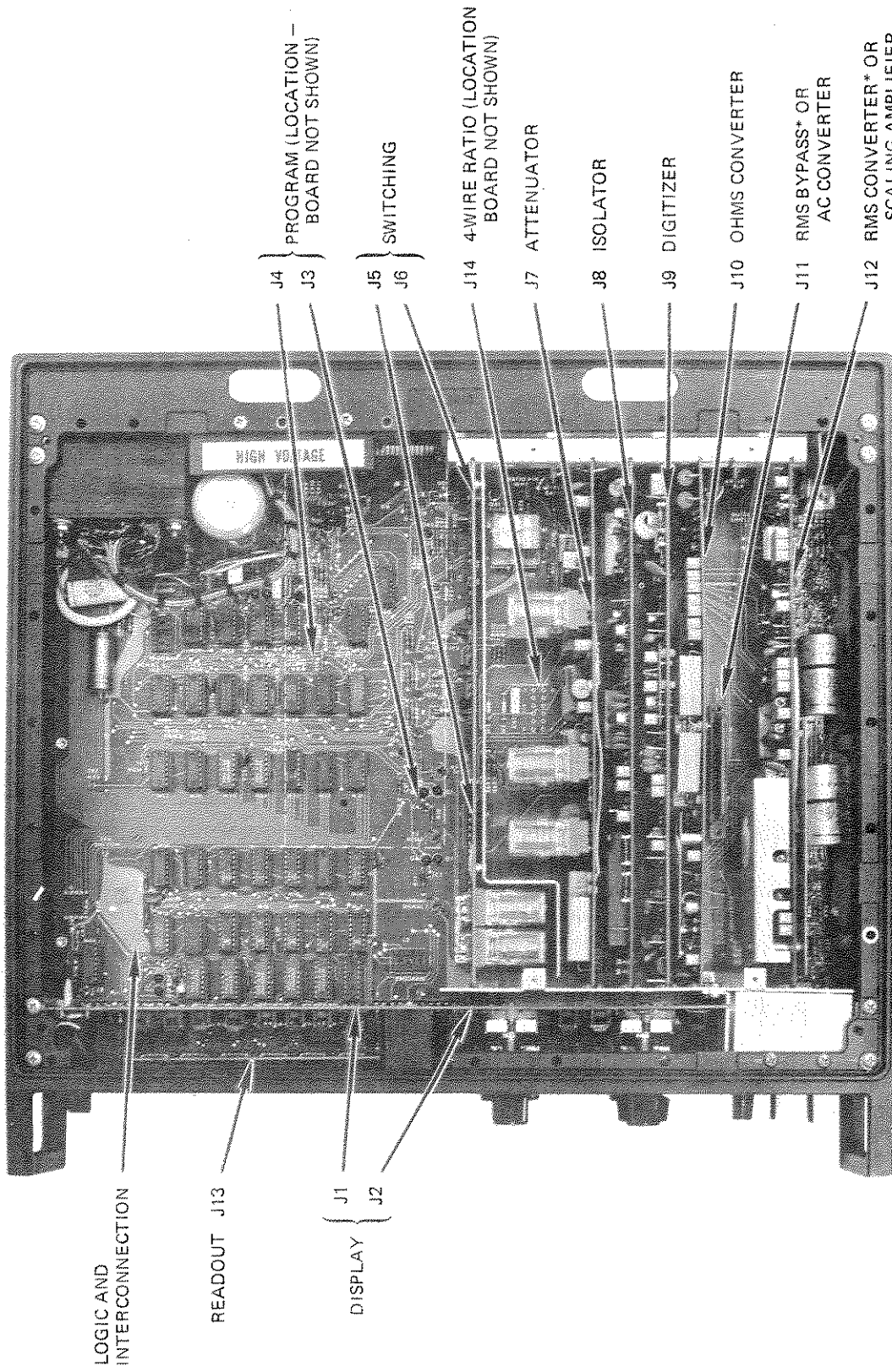

*INSTRUMENT SHOWN IS EQUIPPED WITH RMS CONVERTER.

Figure 4.1 - Mechanical Assembly

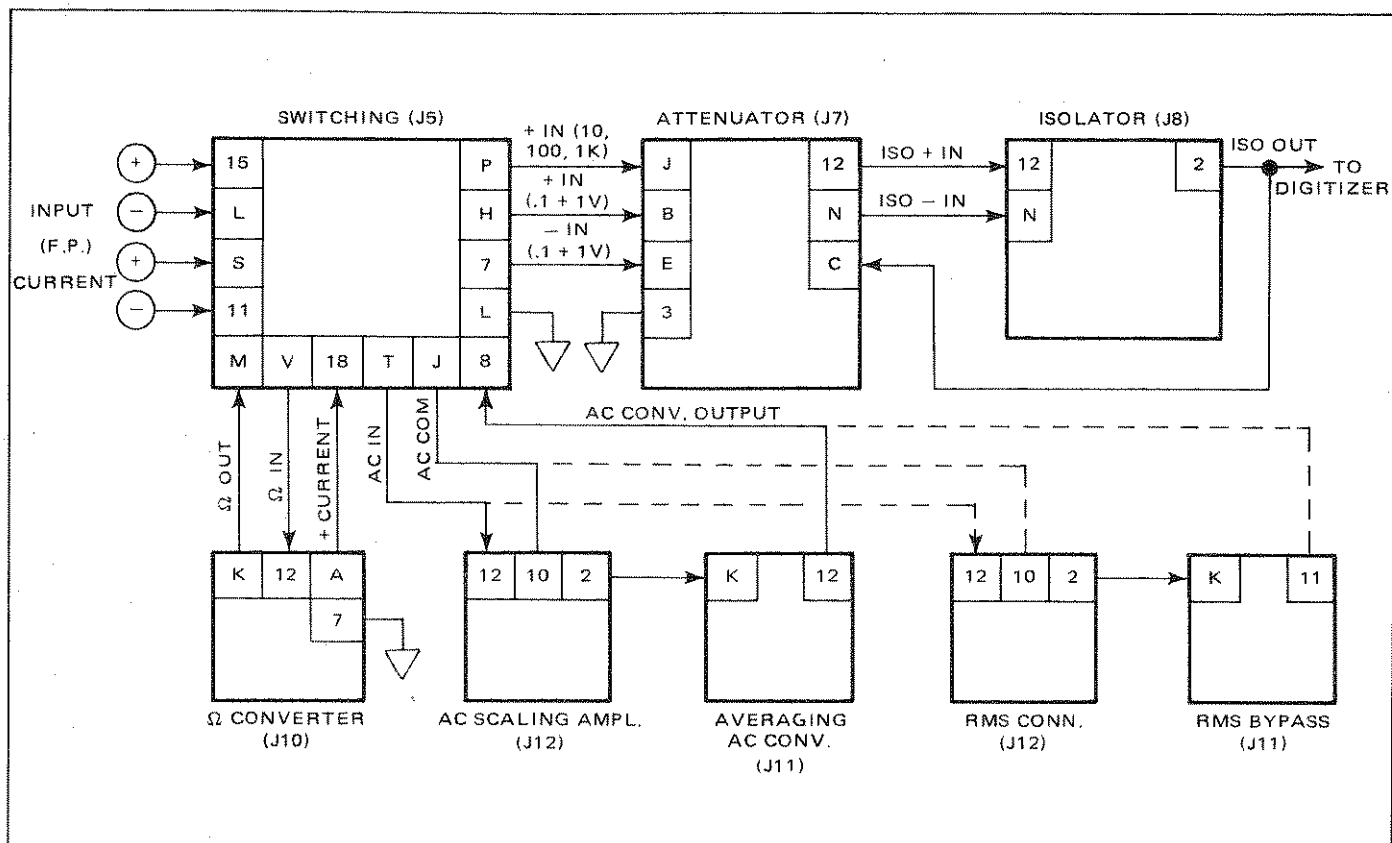

Figure 4.2 - Signal Flow, Loaded DVM

4.16 The Ohms Converter, in conjunction with the Switching board, the Attenuator, and the Isolator, converts the resistance to be measured into a proportional dc voltage that can be measured by the DVM. The current produced for each range, when applied to a resistance equal to the range selected, generates a voltage at the output of the resistance measurement network of 10 volts.

4.17 The resistance measurement network assumes two forms, depending on the range being measured, as shown in figure 4.6. The basic technique used consists of effectively connecting the resistance to be measured (R_x) as a negative feedback path of an operational amplifier, with the amplifier provided by the Ohms Converter and the input to the operational amplifier formed by the current generator. In this hookup, the current through R_x equals the current generated by the current source. Referring to configuration (a), used for the ranges 10 kilohm through 100 megohm, the voltage developed across R_x is monitored through the $-IN$ front panel connector and buffered by the isolator in a gain-of-one mode. The full scale output for these ranges, as shown in the table, is -10 volts. Referring to figure (b), the isolator is connected in a potentiometric configuration but with the input at an effective ground potential and the reference end of the feedback network tied to the voltage

developed across R_x . The low impedance provided by the isolator feedback network is offset by the current compensation circuit (c.c.). This circuit monitors the output potential of the isolator and produces a current drain precisely equal to the current produced by the feedback network. The result is that the feedback network appears to have an extremely high input impedance. The configuration used in (b) reduces normal the gain of the isolator by 1, thereby producing gains of 99 and 9 as shown in the table.

4.18 Scaling Amplifier.

4.19 The Scaling Amplifier, shown simplified in figure 4.7, is used in conjunction with the Averaging AC Converter and occupies position J12. It provides isolation between the signal being measured and the signal converting circuitry and it scales the input signal to a level suitable for the converter (1V RMS output for a full scale input).

4.20 The Scaling Amplifier consists of an AC coupled operational amplifier with four possible gain settings (X1, X.1, X.01, and X.001). The gain control network is controlled by three relays and these are operated from decoded data from the range logic. A change in the roll off of the amplifier is provided when the 1 volt range is selected.

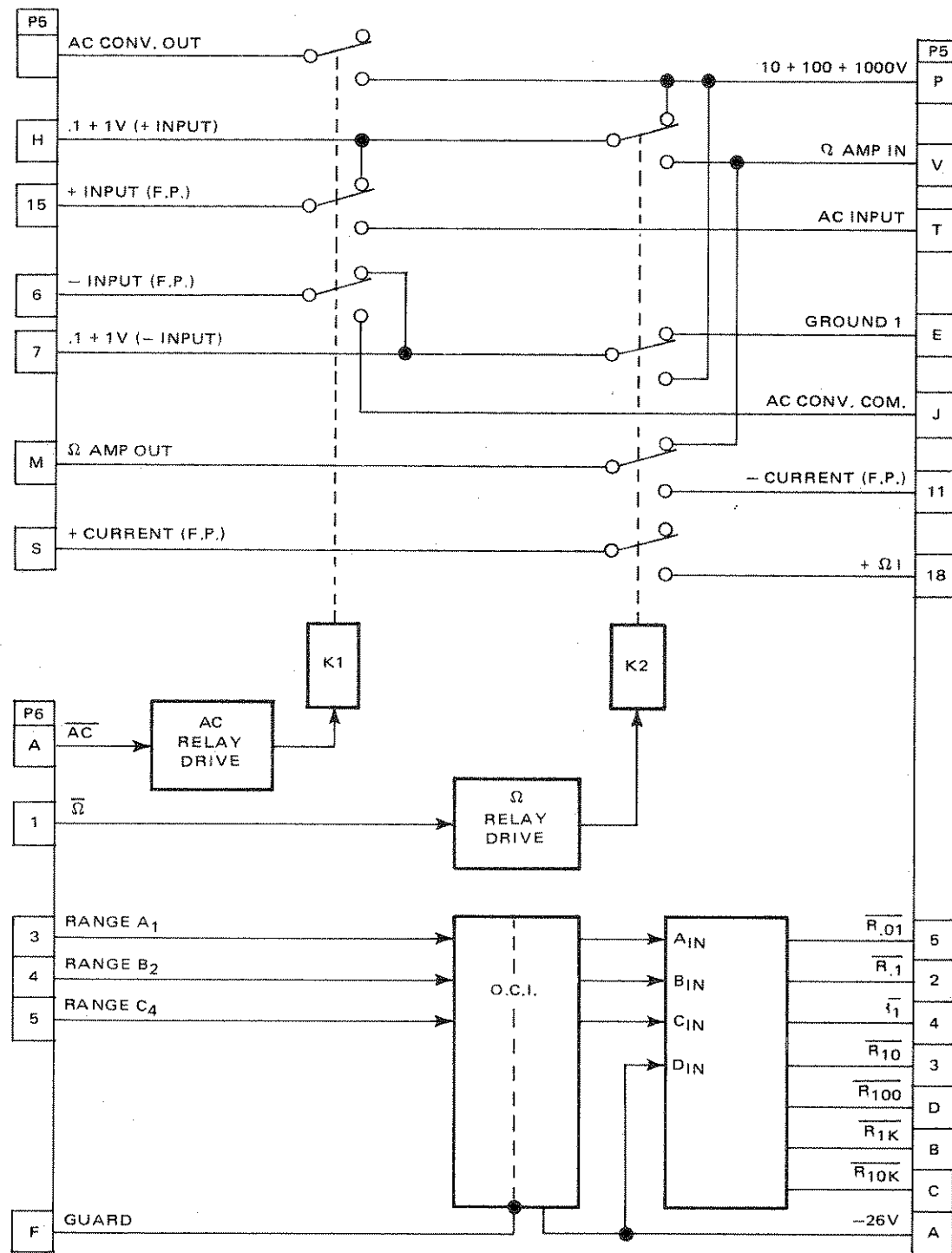
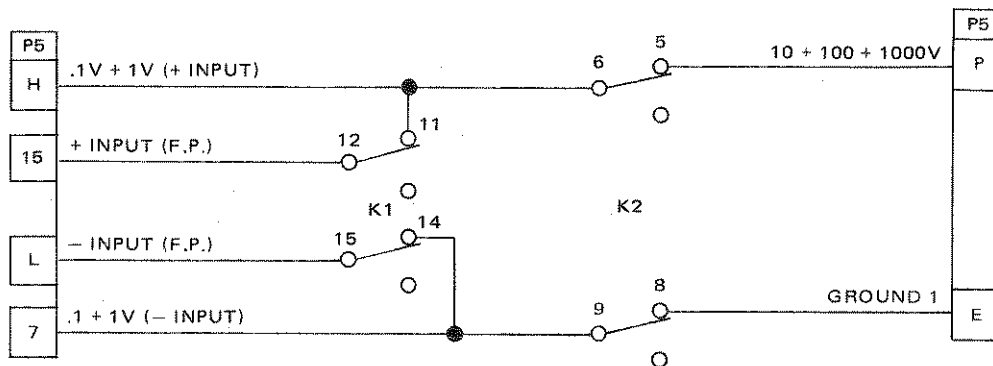
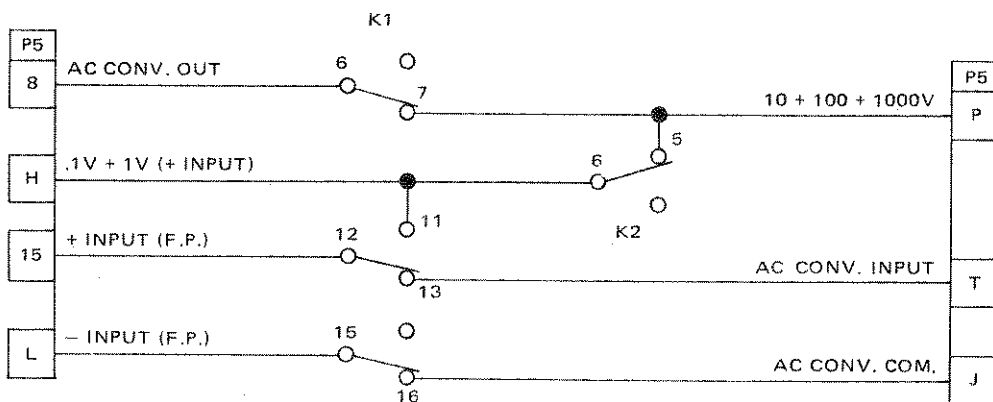

Figure 4.3 - Switching Board



(a) DC Routing



(b) AC Routing

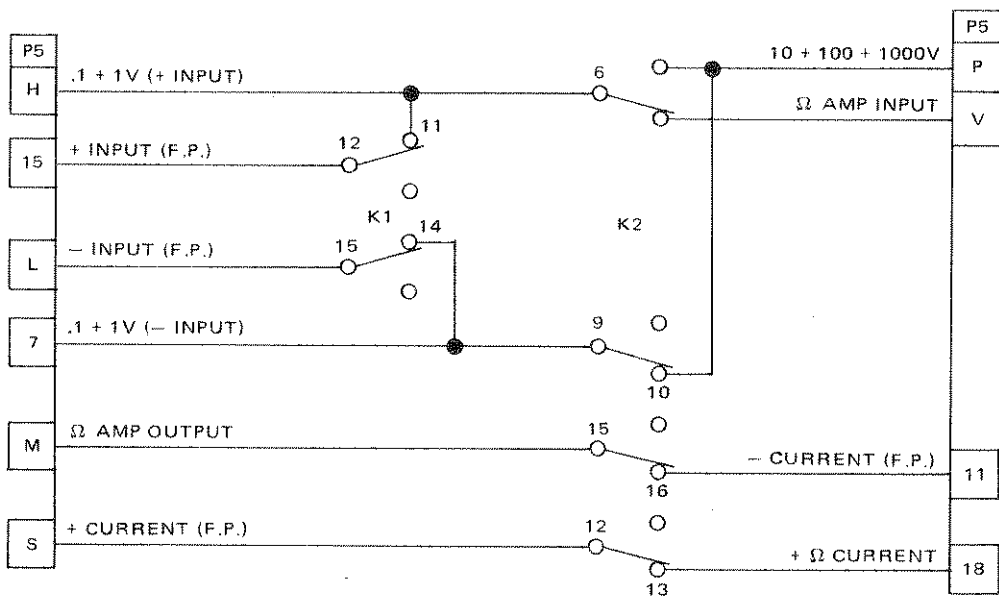

(c) Ω Routing

Figure 4.4 - Signal Flow of Switching Board

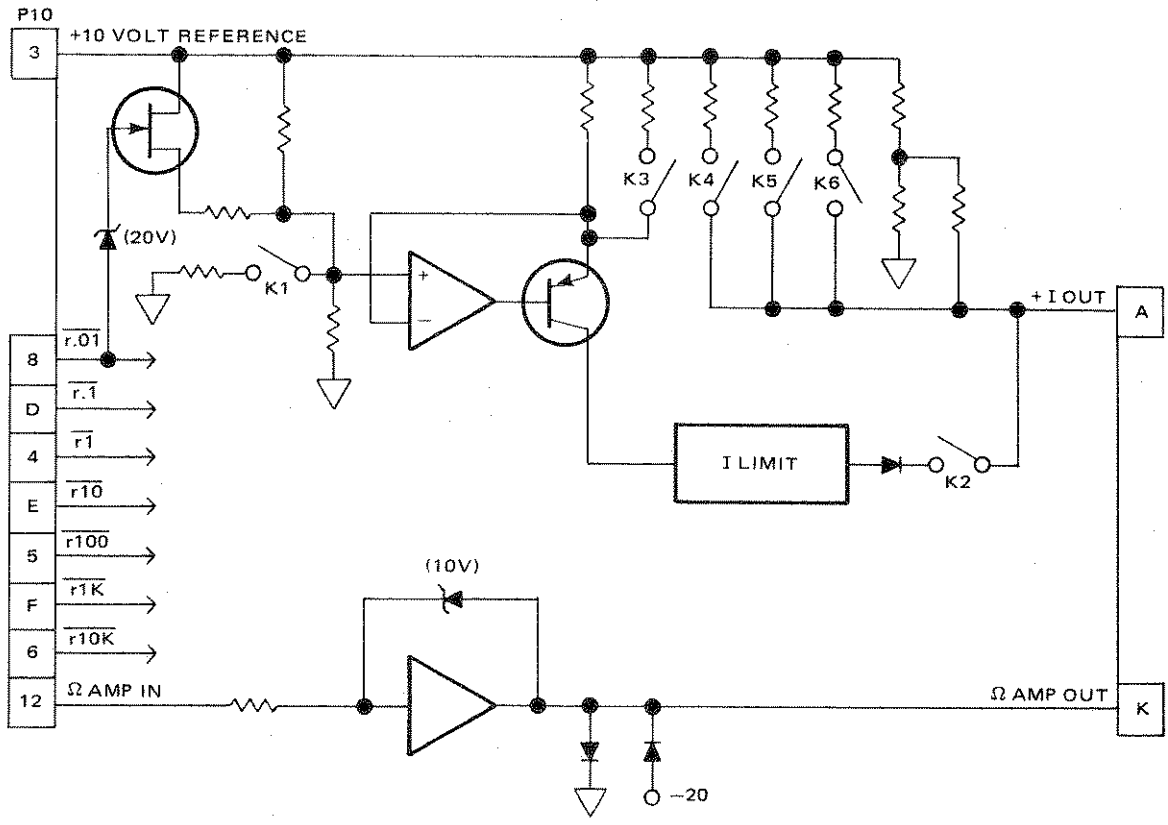

RANGE	K1	K2	K3	K4	K5	K6
r.01		■	■	■		
r.1	■	■	■			
r1	■	■				
r10		■				
r100			■			
r1K				■		
r10K						■

■ RELAY ENERGIZED

Figure 4.5 - Ohms Converter

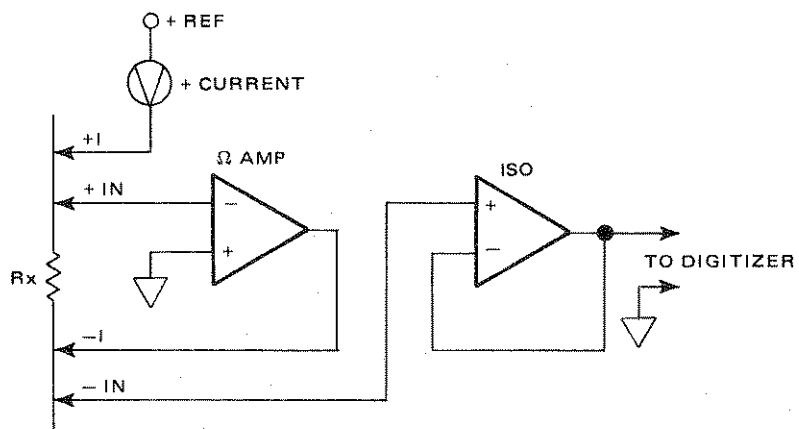

RANGE	CURRENT	FULL SCALE OUT
10 KΩ	1 mA	-10V
100 KΩ	100 μA	
1000 KΩ	10 μA	
10 MΩ	1 μA	
100 MΩ	100 nA	

(a)

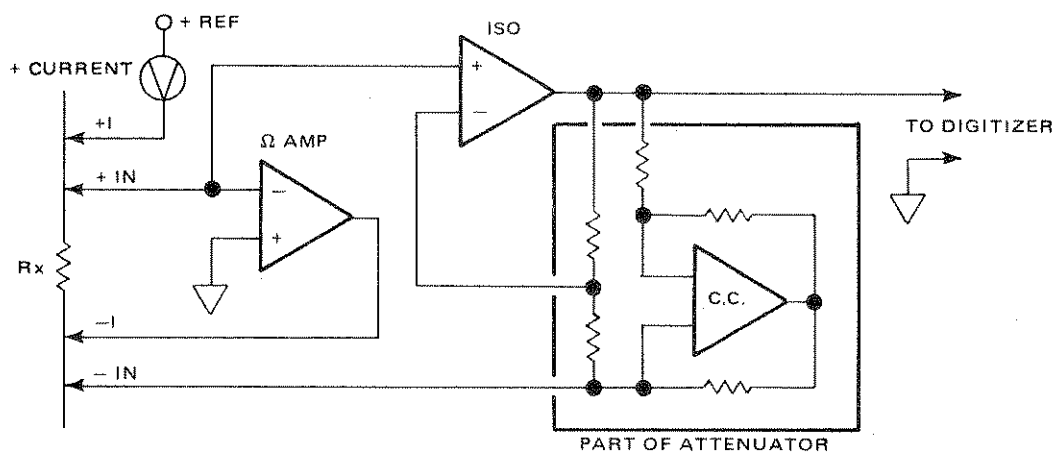

RANGE	CURRENT	GAIN	F.S. OUT
10Ω	10.1 mA	99	+10V
0.1 KΩ	11.1111 mA	9	+10V
1 KΩ	1.11111 mA	9	+10V

(b)

Figure 4.6 - Ohms Measurement Systems

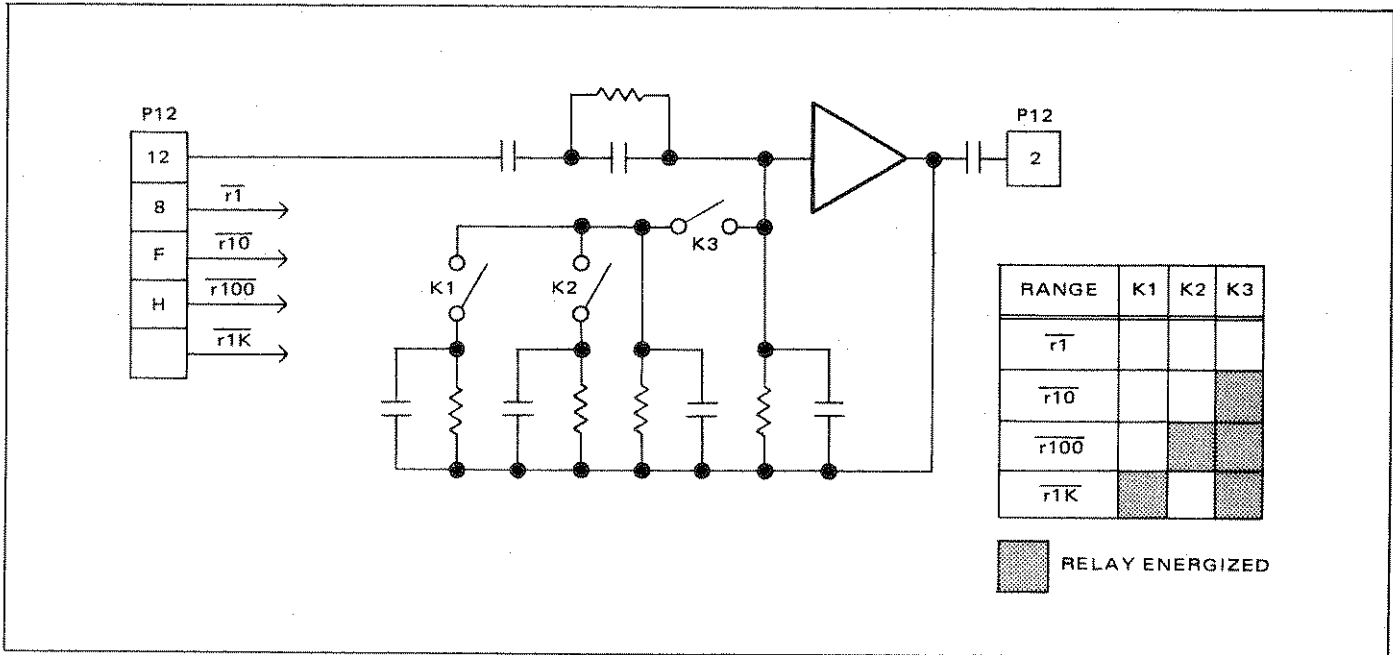

Figure 4.7 - Scaling Amplifier

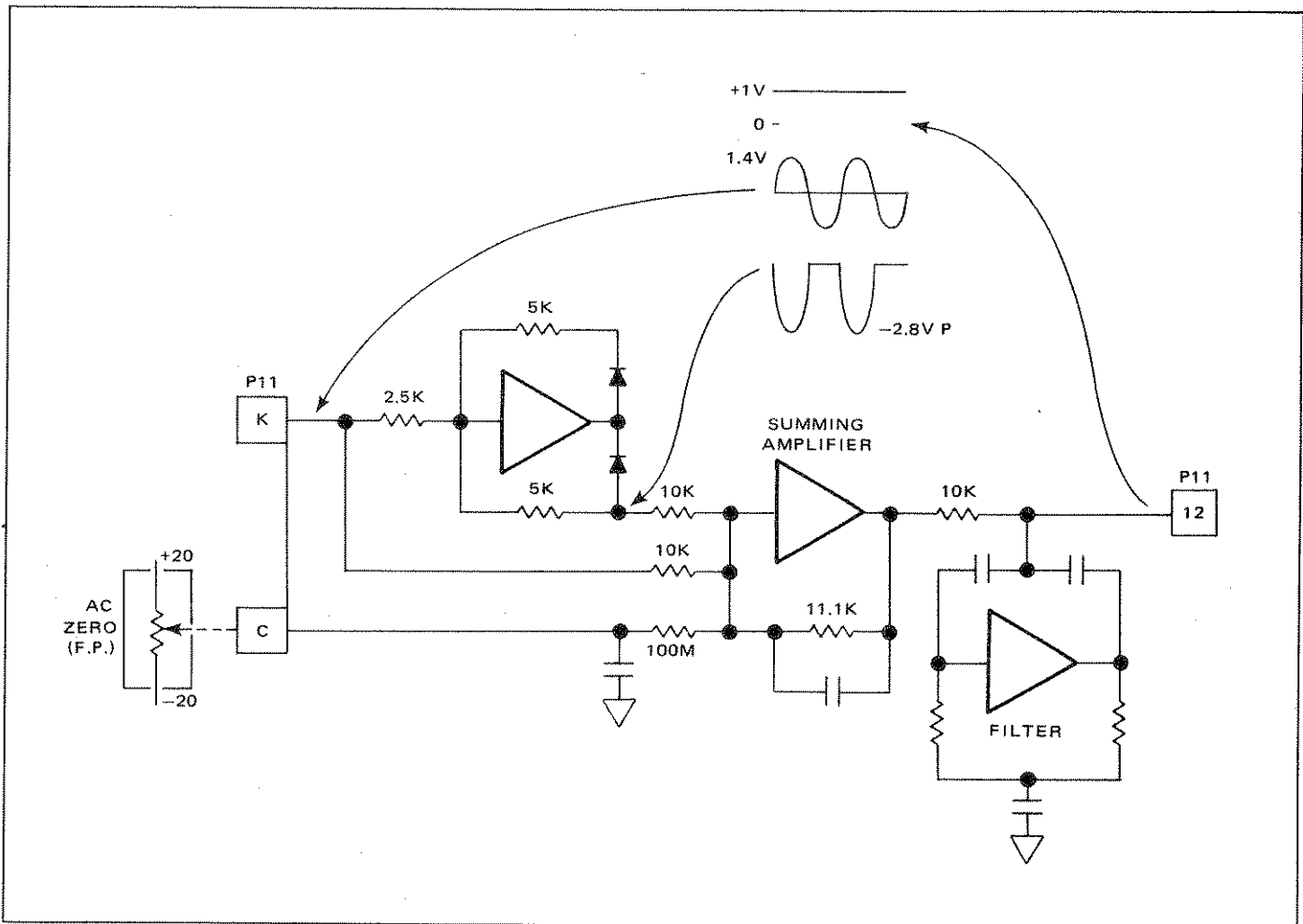

Figure 4.8 - Averaging AC Converter

4.21 Averaging AC Converter.

4.22 The Averaging AC Converter receives the scaled input from the Scaling Amplifier and generates a positive dc equivalent for the DVM measurement section. The circuitry is mounted on a single printed circuit board and occupies location J11 on the Main Logic board. The circuitry, shown simplified in figure 4.8, consists of an active rectifier, a summing amplifier, and an active filter circuit.

4.23 Referring to figure 4.8, a full scale input (1.414 volts peak) is shown applied to the input of the active rectifier. The active rectifier consists of an operational amplifier having two polarity selective feedback loops (one positive, one negative), and the closed loop gain of the circuits is set at 2. The output of the negative going feedback loop is fed through a resistor to the summing node of the summing amplifier. Also fed to this summing node and through a resistor is the full wave input signal. The summing amplifier adds the two inputs, averages them and multiplies the signal by 1.11 to produce the dc equivalent of the RMS input, or 1 volt dc. The ripple content is attenuated by the summing amplifier. A full scale input of 100 Hz would result in a ripple at the summing amplifier output of ≈ 50 millivolts. Further ripple attenuation is provided by the active 3-pole filter. For the same example, the filter would increase the ripple attenuation to ≈ 5 millivolts.

4.24 RMS AC Converter.

4.25 The circuitry is shown simplified in figure 4.9. The Scaling Amplifier consists of an operational amplifier with a fixed input impedance and four feedback paths. The feedback path for the one volt range is permanently wired into the circuit; the 10, 100, and 1000 volt range feedback paths are connected in parallel to the 1 volt feedback path by relays K1, K2, and K3. The scaling amplifier supplies an accurate 1 volt output on each range selected with full range inputs applied.

4.26 The active rectifier is an operational amplifier with two polarity selective feedback paths (one conducting only with a positive amplifier output and the other conducting only with a negative amplifier output). The voltage developed across the positive conducting leg is applied through a 10K resistor to the summing node of the log amplifier along with the full wave signal through a 20K resistor from the output of the scaling amplifier. These two inputs are combined and, due to the non-linear feedback loop of the log amplifier (consisting of Q14A and Q15A) produce the log of the combined signal at \odot . This signal is fed through an identical path (consisting of transistors Q15B and Q14B) to the input of the summing amplifier.

4.27 The summing amplifier converts the signal to a dc level. The ripple content of the dc level is attenuated and the output reduced to provide a dc equivalent of the RMS value of the ac input signal.

4.28 Attenuator.

4.29 The Attenuator board is a single printed circuit board and occupies connector J7 on the Main Logic board. The Attenuator consists of a relay controlled voltage divider used on dc function that provides selectable scaling factors of X1, X.1, and X.01; a relay controlled feedback network used in conjunction with the isolator that provides selectable gain factors of X1, X10, and X100; and current compensation circuitry used in conjunction with the ohms converter.

4.30 Isolator.

4.31 The Isolator is a single printed circuit board and occupies connector J8 on the Main Logic board. The Isolator consists of a high open-loop-gain amplifier, a bootstrap amplifier, and a 3-pole filter. The amplifier is used potentiometrically and operates in conjunction with the attenuator board as shown in figure 4.10.

4.32 The bootstrap amplifier generates the + and - supply voltages for the input stages of the isolator, causing them to track the input signal. This results in an effective input impedance of greater than 10,000 megohms. The filter is an active 3-pole Bessel type connected by relay K1 to a point between the gain stage and the post amplifier of the isolator. The filter increases normal mode noise rejection from 10 to 48 dB (at 59 Hz) when K1 is energized. Filter selection is through the front panel switch or the remote programming option.

4.33 Switching Bypass.

4.34 The Switching Bypass board is a printed circuit jumper board and occupies connector J5. The Bypass board replaces the Switching board when the Ohms and AC converter options are not used in the DVM. The signals are routed through the Bypass board in exactly the same manner as in the Switching board when the dc function is selected. A block diagram of the Signal Conditioning section with the Bypass board installed is shown in figure 4.11.

4.35 INTEGRATION.

4.36 The Model 5900 uses an improved version of the standard dual slope integration method of analog-to-digital conversion, called delayed dual slope. As in the standard technique, the input signal is integrated for a set time

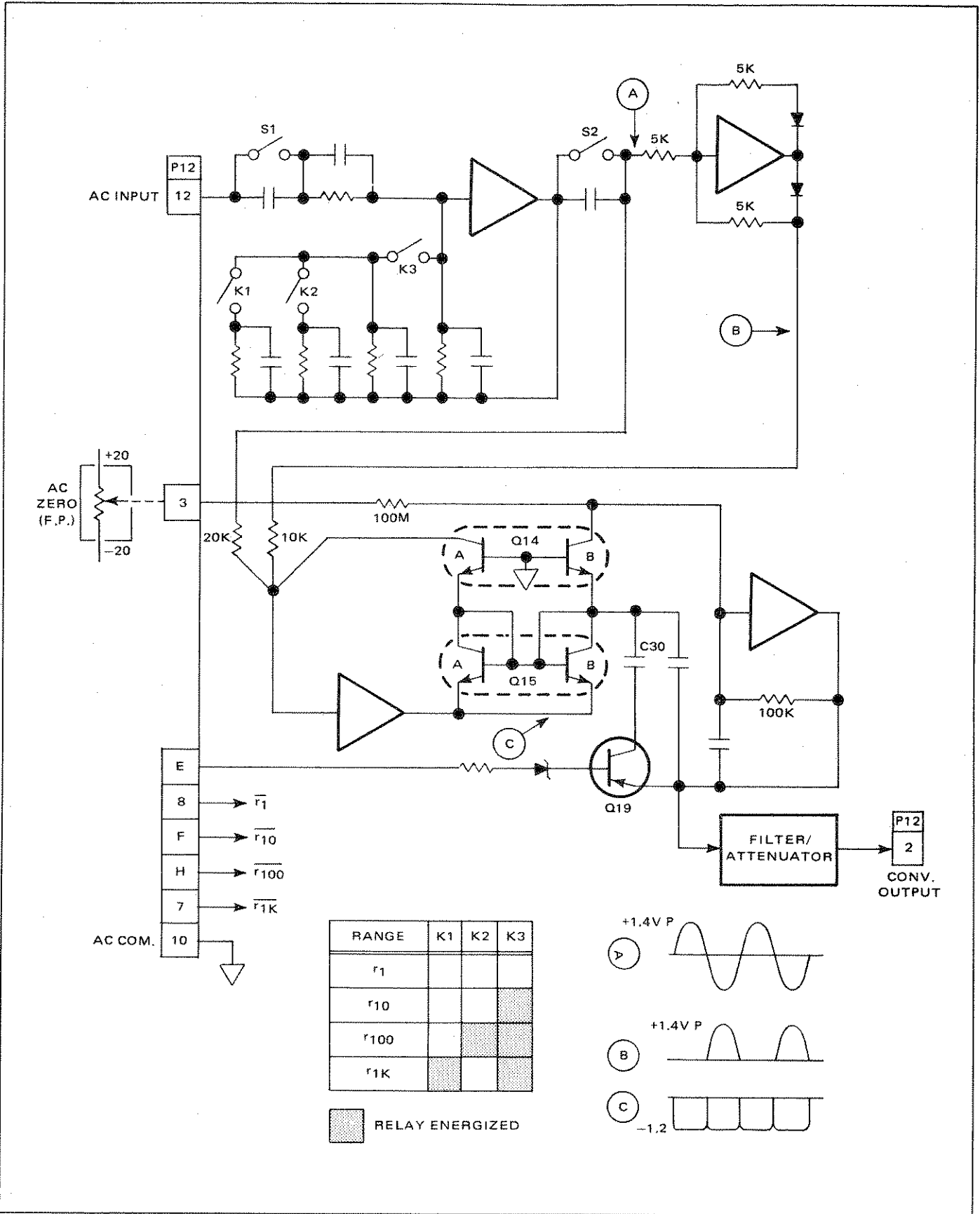

Figure 4.9 - RMS AC Converter

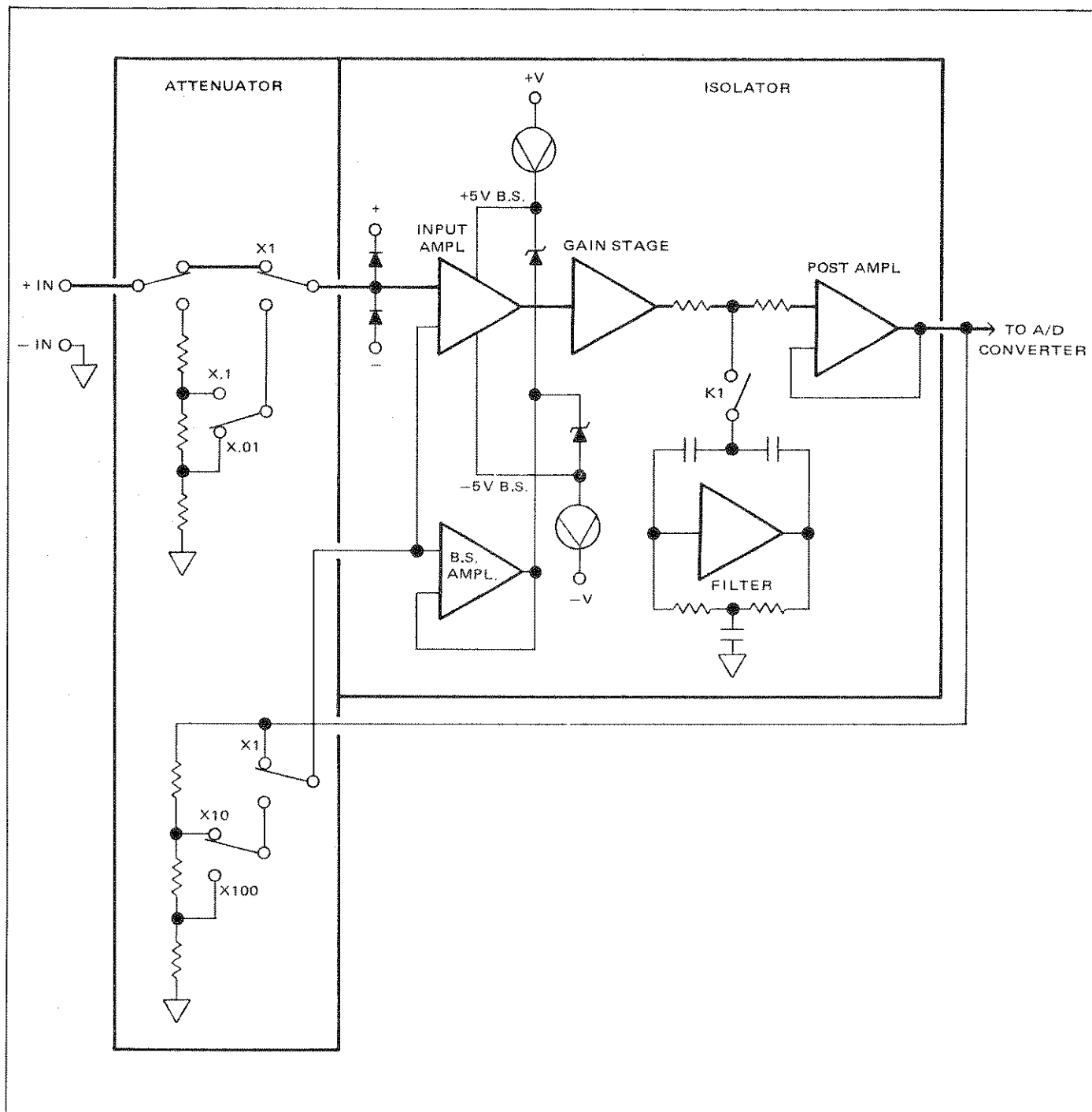

Figure 4.10 - Attenuator/Isolator DC

period to produce a voltage that is directly proportional to the input signal. At the conclusion of this signal integration period, the input signal is removed from the integrator and replaced by a fixed reference voltage whose polarity is opposite that of the input signal. This causes the integrate output voltage to discharge at a linear and fixed rate for a time period that is directly proportional to the voltage developed during the signal integration period. This reference integration time period is measured and displayed

in the instrument readout. The transition from signal to reference integration in the A to D sequence, is accompanied by switch noise in the form of spikes. Due to this and normal mode noise which may accompany the input signal, the standard dual slope technique is subject to noise induced errors with input signals at or near zero. The delayed dual slope technique used in the Model 5900 DVM minimizes this source of measurement error by generating a period of non-measurement or delay between the two integration

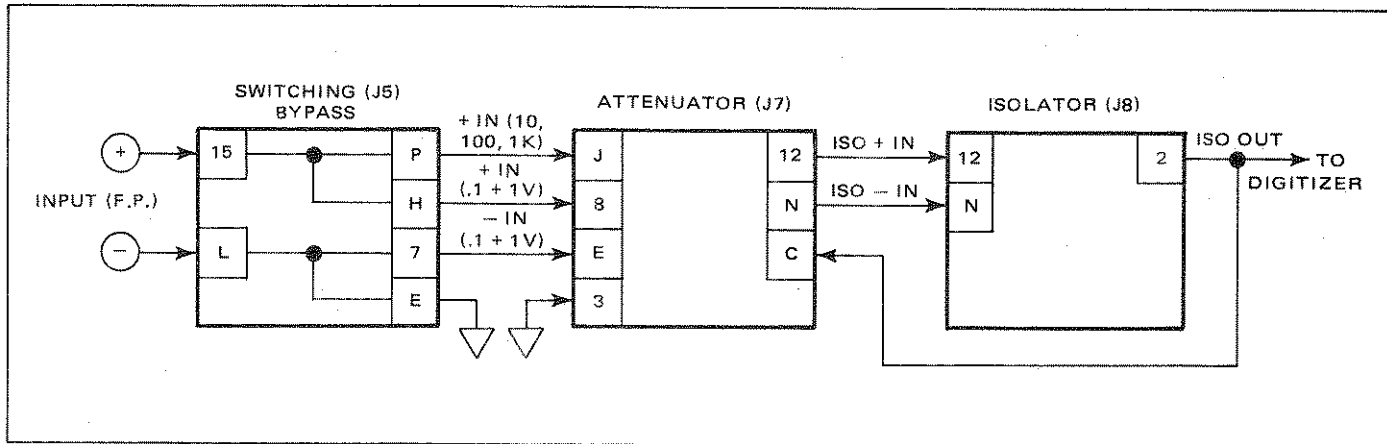

Figure 4.11 - Signal Flow, Switching Bypass

periods. The circuitry used to perform this task include both the Digitizer and portions of the Display/Logic section. In the Digitizer, shown in simplified form in figure 4.12, this is reflected as an adjustment to the basic shape of the integrator output signal as shown in figure 4.13. The 'delay' portion of the integration cycle is initiated immediately following the signal integrate period and is the result of two factors. First, an analog level equal to 180 digits and of a polarity that resists the axis crossing from occurring, is produced at the integrator output by a network called the feed forward circuitry. Second, a capacitor in the feedback network of the gain stage that follows the integrator adds to the total delay period. The total effect is a fixed delay of the axis crossing signal of 200 digits.

4.37 Digitizer.

4.38 The circuitry that performs the A/D conversion is mounted on the single, printed circuit Digitizer board and occupies connector J9 on the Main Logic board. The circuitry includes: an integrator and switching network, a gain stage, null detector, transformer driver, signal and reset logic, switch controls and + and - reference supplies.

4.39 INTEGRATOR.

4.40 The Integrator consists of an operational amplifier with a capacitive feedback path to convert the dc levels applied to its input to a corresponding ramp voltage at the integrator output. The use of a dual FET input stage provides a correspondingly high input impedance and permitting capacitor input coupling during the integration period and allowing auto-zeroing during reset. The feed forward circuitry is a voltage divider network that takes a portion of the reference voltage and applying it to the non-inverting input of the integrator. This results in an equal amount of voltage appearing at the integrator output.

4.41 The integrator switches consist of junction FET's, controlled by circuitry located on the Digitizer. Referring to figure 4.12, switch S1 conducts during the signal integration period, switch S2 or S3 during reference integration and S4 and S5 during reset. The output of the integrator is coupled to the following Gain Stage through two FET's connected as current generators. The purpose of these generators is to prevent loading of the Integrator while maintaining reasonable coupling to the gain stage input.

4.42 GAIN STAGE.

4.43 The gain stage greatly increases the amplitude of the integrator output especially in the area near zero to provide a more clearly defined axis crossing signal for the null detector to respond to. The gain stage also exhibits low pass filter characteristics which, as previously discussed, adds to the total delay of the integration sequence. This reduces the total noise response of the system and reduces the wide band response requirements of the null detector. The circuit consists of a potentiometric amplifier with a programmed gain control, providing gains of 300 for stage inputs of up to 13 mV and decreasing to 14 for signals above this level.

4.44 NULL DETECTOR.

4.45 The Null Detector consists of an inverting, open-loop amplifier with an output swing of 5 volts. The Null Detector converts the amplified analog signal (ramp) from the integrator to a digital level (logic 1 \approx +5 volts and logic 0 \approx 0 volts). This digital signal, called either the null detector output or axis signal is used on the Digitizer board for determining the polarity of the reference to be used for the reference integration and, by way of the transformer driver and transformer T1, the circuitry of the Display/Logic section of the main assembly.

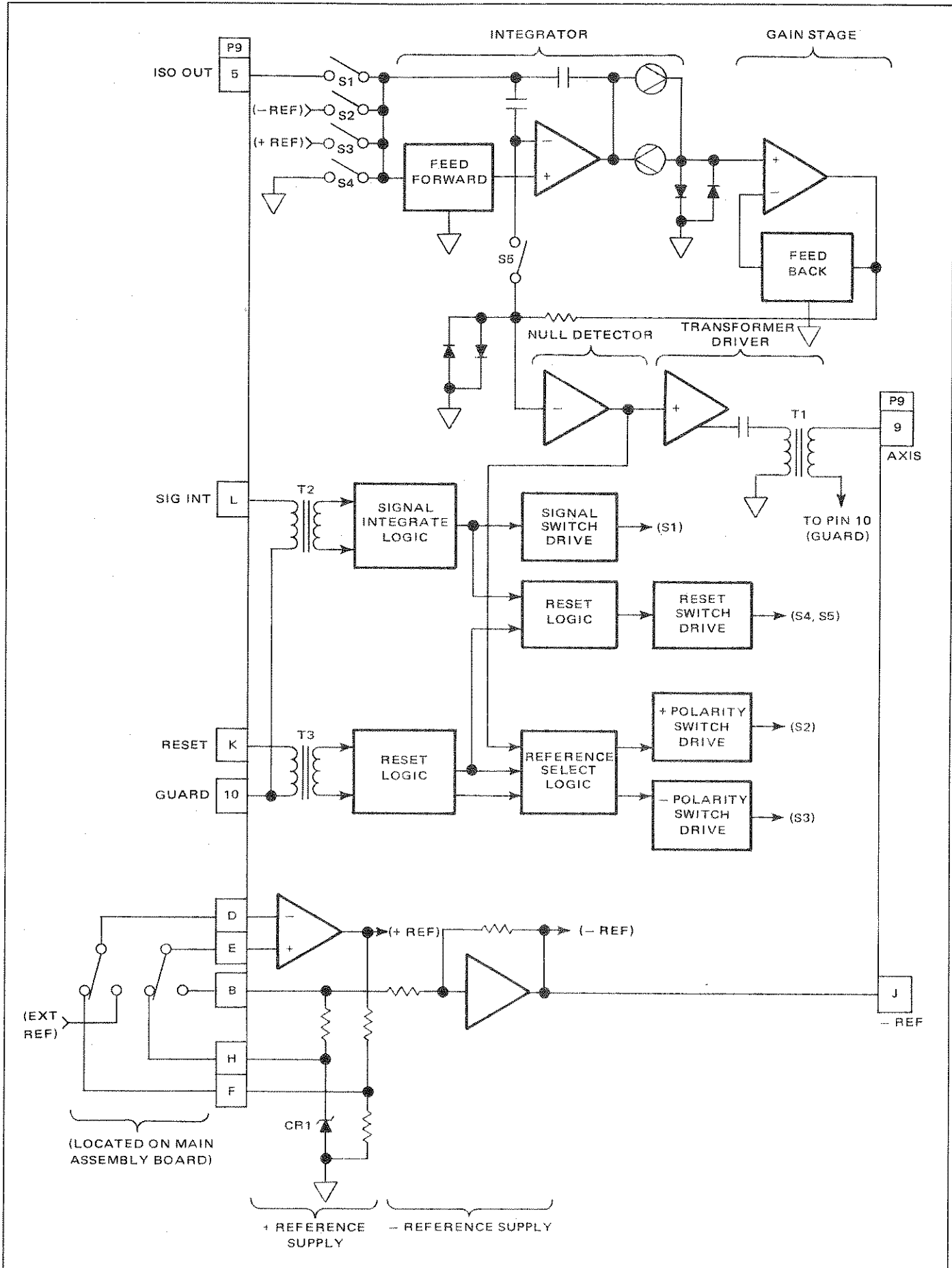

Figure 4.12 - Digitizer

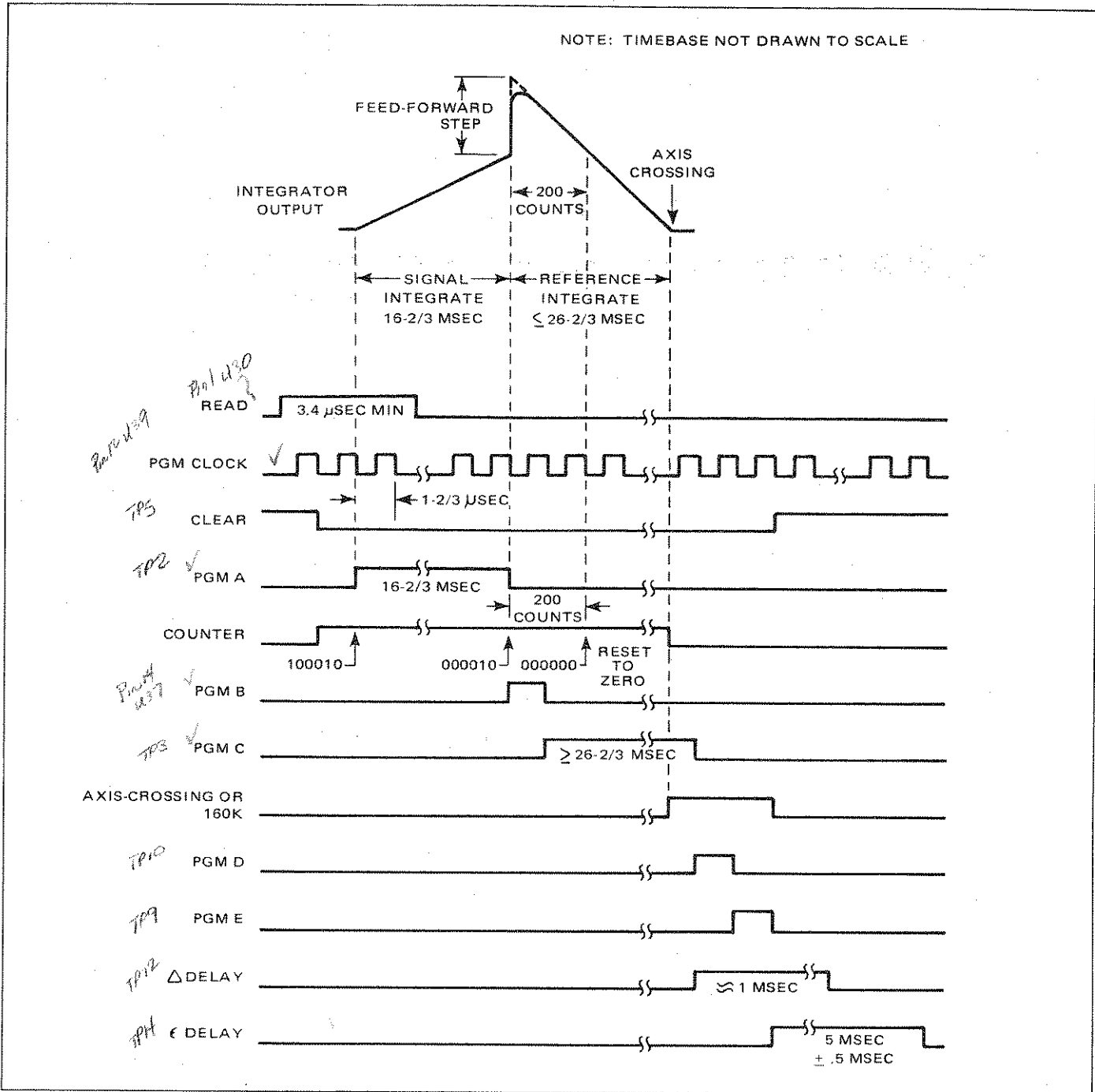

Figure 4.13 - Integration Timing Diagram

4.46 TRANSFORMER DRIVER.

4.47 This circuit consists of a complementary emitter-follower, capacitor coupled to the isolation transformer T1.

4.48 SIGNAL AND RESET LOGIC.

4.49 This circuitry operates from pulse data obtained through isolation transformers T2, T3 and originating from control circuitry of the Display/Logic section. The data is converted into control signals for operating the integration switches.

4.50 DIGITIZER LOGIC.

4.51 The Digitizer Logic receives its timing information through isolating data transformers T2 and T3. The logic converts this information into control signals that operate the FET switches. The timing of the input data and switch operation is provided in figure 4.13.

4.52 Ratio, Standard.

4.53 The standard ratio consists of relay K1 on the interconnect board. When nonenergized, this relay routes the

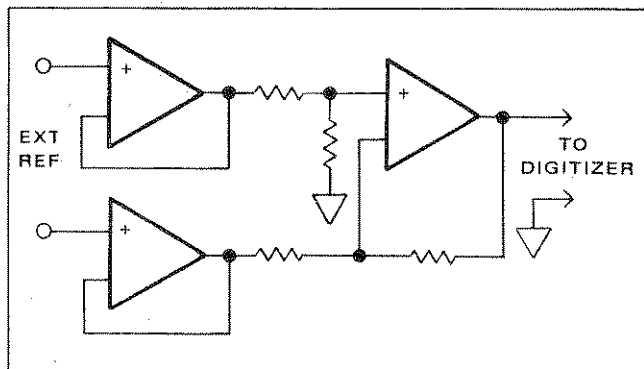

Figure 4.14 - 4-Wire Ratio Option

outputs of the internal zener reference bridge to the reference amplifier (both located on the reference amplifier assembly) and produces a fixed + and - 10 volts; when energized (Ratio selected) the relay reroutes the signal flow, replacing the zener input with the EXT REF input and converting the +10 output amplifier to a noninverting gain of one amplifier.

4.54 Ratio Option.

4.55 The four wire ratio circuitry is mounted on a single printed circuit board and occupies connector J14 on the Main Logic board. The 4-wire ratio option eliminates ground loop errors in ratio measurements by permitting the reference input common lead to float in reference to the signal input common. The circuitry, shown in figure 4.14, consists of two gain-of-one isolation amplifiers driving a differential potentiometric amplifier. Field installation of

the ratio board requires removal of jumpers W1 and W2 on the Main Logic board.

4.56 Display Board.

4.57 The Display board is a single printed circuit board and occupies connectors J1 and J2 on the Main Logic board. The display board is located directly behind and parallel to the front panel of the instrument; the function and range control knobs on the front panel are connected by shafts to the rotary switches on the display board. A mechanical interlock attached between the two shafts prevents the manual selection of incorrect function/range combinations. The display board contains the function, the manual and autorange, and the annunciator circuitry. The circuit is shown in simplified block form in figure 4.15 and described below.

4.58 FUNCTION AND RANGE SWITCHES.

4.59 These generate a negative true output and operate only in local control (programming not selected). The function switch has three positions generating outputs (from left to right) of \overline{AC} , \overline{DC} , and $\overline{\Omega}$. The range switch has nine positions and generates the outputs shown in table 4.2.

4.60 DATA ENCODE.

4.61 The output of the range switch is converted to positive true 1248 BCD logic by this circuitry. The BCD

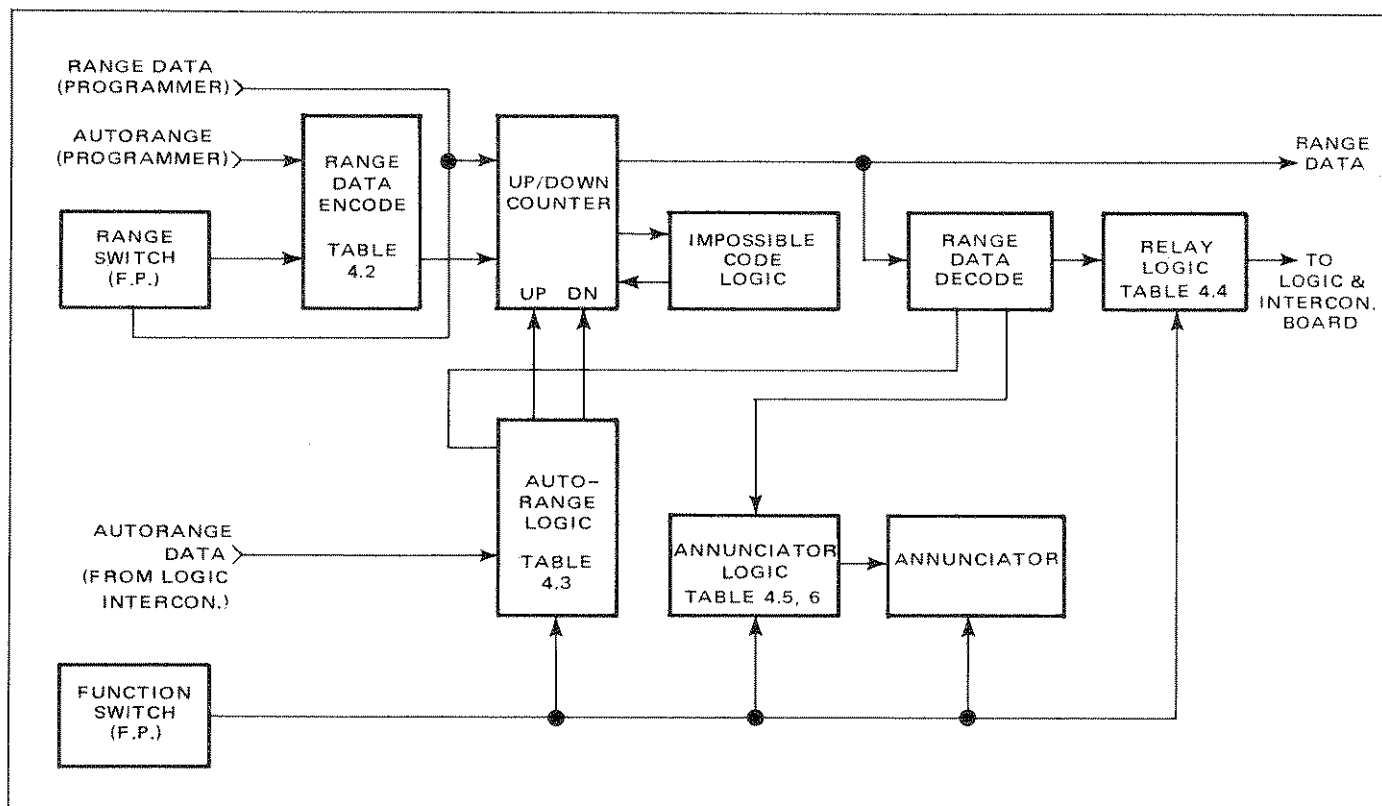

Figure 4.15 - Display Board

Table 4.2 - Range Switch Code

RANGE SWITCH	SWITCH OUTPUT	DATA ENCODE OUTPUT				BINARY WEIGHT
		A	B	C	D	
10 Ω	$\overline{R2}$	F	T	F	F	2
.1	$\overline{R3}$	T	T	F	F	3
1	$\overline{R4}$	F	F	T	F	4
10	$\overline{R5}$	T	F	T	F	5
100	$\overline{R6}$	F	T	T	F	6
1000	$\overline{R7}$	T	T	T	F	7
AUTO	-	F	F	F	F	0
10M	$\overline{R8}$	F	F	F	T	8
100M	$\overline{R9}$	T	F	F	T	9

output is the same as produced by the programmer for remote range selection and is shown in table 4.2. The four BCD output lines from the data encode are applied to the up/down counter.

4.62 UP/DOWN COUNTER.

4.63 The up/down counter is a decade counter capable of counting up from 0 to 9 and overflowing to 0, counting down from 9 to 0 and overflowing to 9, being preset to the BCD input, and being cleared to zero. In manual range the up/down counter is held in the preset mode and the output of the counter always equals the BCD code from the data encode circuitry. In autorange the BCD input from the range data encode is inhibited and the output of the counter is controlled by the autorange logic.

4.64 AUTORANGE LOGIC.

4.65 The autorange logic generates the control pulses for advancing the counter up or down. Data are received from the function switch and from the range data decode circuit, a BCD to 10-line converter. If no range change is required the circuitry generates no control signals and the counter is not advanced. An up range signal is generated during the Program D period if an up range 160% signal is true and the up range inhibit signal is not false (see table 4.3). One up range signal is generated per measurement cycle. A down range signal is generated during the Program D period if the down range 15% signal is true and the down range inhibit signal is not false (see table 4.3). One down range signal of this type is generated for each measurement cycle. In the event that the counter is in a forbidden range (not available for the function selected), during the clear period, the counter is made to down range

Table 4.3 - Autorange Logic

DATA	INHIBIT				FORBIDDEN RANGE				
	\overline{UP} RANGE		\overline{DOWN} RANGE						
\overline{DC}			F						
\overline{AC}				F				F	
Ω	F				F				
$\overline{Ω}$		F			F	T	T		
$\overline{R0}$									F
$\overline{R1}$									F
$\overline{R2}$					F	F			
$\overline{R3}$			F						F
$\overline{R4}$				F					
$\overline{R7}$	F								
$\overline{R8}$						F			
$\overline{R9}$		F						F	

at the clock rate until the counter is in an available range. The autorange circuitry then operates normally to select the most appropriate range. The forbidden ranges are indicated in table 4.3. If the counter output produces an 'impossible code' (as could happen when the instrument is turned on and autorange is selected), the impossible code logic resets the counter to zero; the autorange circuitry then selects the appropriate range.

Table 4.4 - Relay Logic Coding

RANGE	FUNCTION						
	Ω		DC			AC	
	.1 +	1 +	.1 +	1 +	100 +	.1 +	1 +
10 Ω							
.1							
1							
10							
100							
1000							
10M							
100M							

 ENERGIZED

Table 4.5 - Annunciator Logic

INPUT	ANNUNCIATOR												
	PGM	FILTER	RATIO	DC	AC	Ω	K Ω	MEG		NO	+	-	
$\overline{\text{SYSTEM CONTROL}}$	F									SEE TABLE 4.6			
$\overline{\text{FILTER}}$		F											
$\overline{\text{RATIO}}$			F										
$\overline{\text{DC}}$				F								F	F
$\overline{\text{AC}}$					F								
$\overline{\Omega}$						F	F	F	F				
W1 (JUMPER)						IN	IN	IN	IN				
W2 (JUMPER)					IN								
$\overline{\text{R2}}$						F							
$\overline{\text{R8}}$							T	F					
$\overline{\text{R9}}$							T		F				
+ POLARITY												T	
- POLARITY													T

4.66 RELAY LOGIC.

4.67 The relay logic is generated by data from the range data decode and the function switch and is used via optically coupled isolators on the Main Logic board to control the attenuator range relays. The codes as shown in table 4.4 indicate the attenuator relay closure.

4.68 ANNUNCIATOR LOGIC.

4.69 The annunciator logic controls the selection of the annunciator lamps as shown in tables 4.5 and 4.6.

4.70 MAIN LOGIC AND CONTROL CIRCUITRY.

4.71 This circuitry, shown in the block diagram of figure 4.16, is located on the Main Logic board and consists of the control and display logic. In general this circuitry controls all instrument operation including the integration cycle, 'times' the output of the digitizer, and converts this information into data compatible with the Display board.

4.72 Control Logic.

4.73 This circuitry controls the operation of the instrument and consists of the program logic, program counter,

Table 4.6 - "NO" Annunciator Logic

INPUT	NO											
UP RANGE 160%	T											
CLEAR		T	T	T	T	T	T					
$\overline{\text{R0}}$		F										
$\overline{\text{R1}}$			F									
$\overline{\text{R2}}$						F						
$\overline{\text{R3}}$								F				
$\overline{\text{R7}}$				F								
$\overline{\text{R8}}$					F							
$\overline{\Omega}$				T	T	T					F	
$\overline{\text{AC}}$								F				F
PROGRAM										T		
$\overline{\text{SYSTEM CONTROL}}$										T		
W1 JUMPER											OUT	
W2 JUMPER												OUT

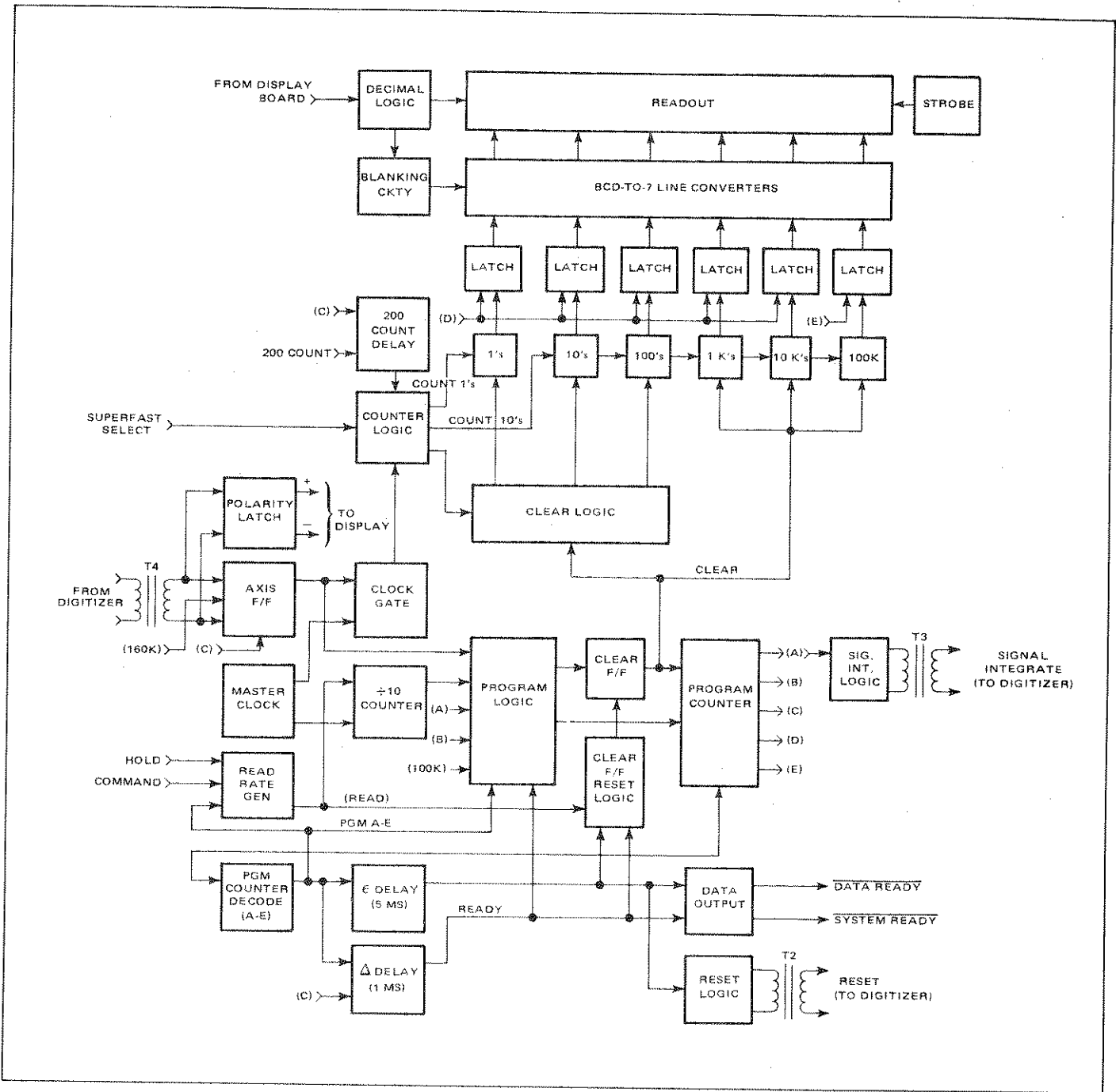

Figure 4.16 - Main Logic & Control Block Diagram

program clock, read rate generator, master clock, clear logic, and counter logic. The instrument operates on a five step program cycle produced by the program circuitry. This consists of a five stage shift register (or program counter), a program clock, and control logic. The five outputs of the program counter correspond to the five program states (PGM A, PGM B, PGM C, PGM D, and PGM E). Only one output of the counter is true at any time during the measurement cycle of the instrument and all of the

outputs are false when the instrument is in clear. The program counter is advanced by a gated square wave from the program clock. The program clock output is driven by and equal to the master clock frequency divided by 10 or 600 kHz and is synchronized with the counter at the start of each measurement cycle. The correlation between the master and program clocks causes a 10 count lag between the program counters advancing during the signal integration period and the counter.

4.74 Program Cycle.

4.75 Preceding the start of the measurement cycle, the instrument is in a clear state with the counter set to 100000 and the logic in the reset state. Upon receipt of a read command, whether from the read rate generator or by an external command, the clear signal is removed and the counter begins counting. After ten clock counts (100010) the program counter advances to PGM A. Program A, via the pulse transformer T3, initiates the signal integrate period of the integration cycle on the digitizer board. Program A is terminated after the counter is advanced 100,000 counts. The period is a precise 16-2/3 millisecond and the counter now reads 000010 (the counter overflows to zero at 199,999). At the completion of Program A, Program B is initiated, lasting for 200 clock cycles. This period corresponds to and provides the required digital delay for the analog delay period between the signal and reference integrate periods of the digitizer as described in paragraph 4.36. At the completion of the 200 count delay (PGM B), the 1's, 10's, and 100's decades of the counter are reset, causing the counter to read 000000. At the same time the program counter is advanced to Program C, which in turn enables the axis crossing detector. The program counter remains in this state until (1) an axis crossing signal is received, indicating the reference integration period of the digitizer is completed or (2) the counter reaches 160,000, indicating an overload condition. One of these two inputs causes the axis flip-flop output to go true, inhibiting the clock gate and stopping the counter. The program counter is advanced to Program D and the Δ (delta) delay is initiated. The delta delay lasts for about 1 millisecond and prevents the ready line from going through until after the program counter has completed its cycle. Program D lasts for one program clock cycle and strobes all but the 100K latches. The program counter then advances to Program E which also lasts for one program clock cycle and strobes the 100K latch. At the end of Program E, the Program A-E line goes false, resetting the read rate oscillator, starting the ϵ (epsilon) delay which lasts for 5 milliseconds and generates the reset signal for the digitizer, and generates the clear signal which sets the counter to 100,000 and resets the logic. At the end of the delta delay, the ready line goes true generating the DATA READY output signal and enables the program logic to receive a new read command. At the completion of the epsilon delay, the SYSTEM READY signal is generated and indicates that the instrument is able to accept an external read command. This returns the circuitry to the state at the start of the program cycle.

4.76 Display Logic.

4.77 This circuitry consists of the counter, latches, BCD-to-7 line converters, display strobe, clear logic, decimal logic, and the counter control logic. The counter consists

of five series connected decade counters and a J-K flip-flop, and is capable of counting from 000000 to 199999 and then overflowing to 000000. The counter is driven by the 6 MHz master clock by way of the clock gate and the counter logic. The clock gate permits the counter to advance only during the measurement cycle. The counter logic circuitry routes the clock signal for normal or superfast operation. The clear logic operates in conjunction with the clear flip-flop and the counter logic to clear all or portions of the counter depending on normal or superfast operation for different parts of the measurement cycle. The latches store the information from the counters from the last measurement cycle in the form of BCD data. The units through 10K latches are strobed (the information at the input of the latch is transferred to the latch output I at Program D; the 100K latch is strobed at Program E. The data from the latches are converted to be compatible with the seven segment LED displays by the BCD-to-7 line converter. The converters are also used in conjunction with the decimal logic to provide leading zero blanking. The LEDs on the readout board are controlled by the BCD-to-7 line converters and powered by the driver decoder strobing circuit. This consists of a one-shot driven by a 120 Hz signal. The strobe permits the LED's to operate at their greatest efficiency while maintaining low overall power consumption.

4.78 Superfast.

4.79 This is a high speed operating mode in which the instrument is effectively converted to a four decade instrument. The actual selection of this mode and timing considerations are covered under paragraphs 2.68 and 2.105. Basically the superfast mode is achieved by bypassing the least significant decade (1's) with the counter logic. At the start of a superfast measurement cycle, the 1's decade is in the clear mode and the 6 MHz clock is applied directly to the input of the 10's decade. The signal integration time of the digitizer is reduced from 16-2/3 milliseconds to 1.6-2/3 milliseconds. The 200 digit time period must remain the same as in the standard measurement operation so the instrument is converted back to standard operation during the 200 count delay. At its completion the operation reverts back to superfast and the reference integration period is measured at the same rate the signal integration period was generated.

4.80 Power Supplies.

4.81 There are two separate power supplies used in the Model 5900; one provides the voltage levels required for operating the analog portions of the instrument and the other provides the voltage levels for the digital/display, data output, and programming. The two supplies use a common transformer core and primary winding but the supplies themselves are completely isolated to maintain the common

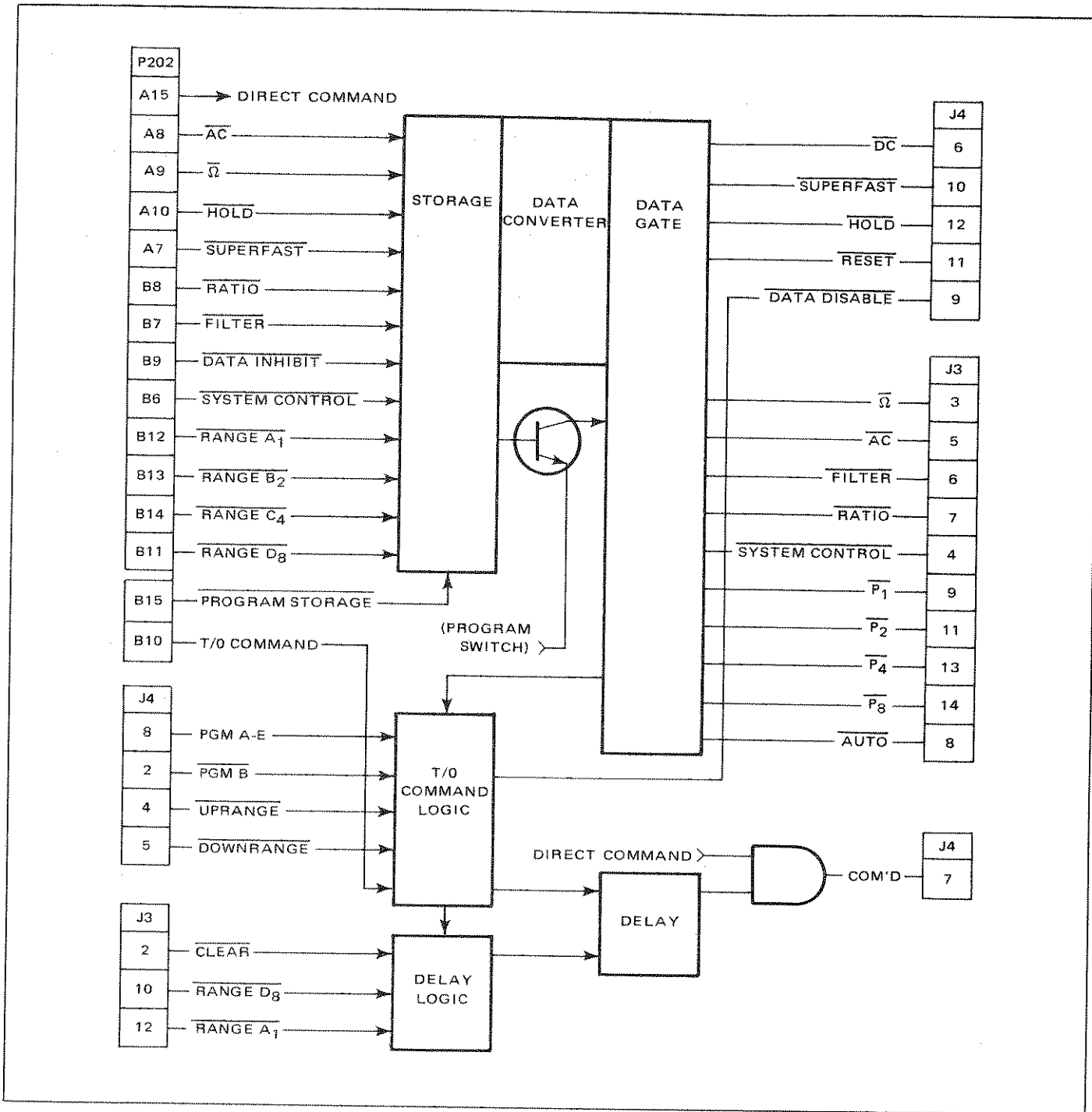

Figure 4.17 - Program Block Diagram

mode rejection characteristics of the instrument. The analog supply provide outputs of ± 25 volts, ± 20 volts, and -40 volts, all referenced to analog common (mecca). The digital supply provides outputs of $+5$ volts, $+5$ volts unregulated, and $+150$ volts, all referenced to digital common.

4.82 Program.

4.83 The program board is an option provided to allow external remote operation of the instrument. The circuitry is mounted on a single printed circuit board. The board is

located above and parallel to the Main Logic board and mounted to the Main Logic board on standoffs. Electrical connection between the Main Logic board and the Program board is by way of two cables (J3-J3A and J4-J4A). A portion of one end of the Program board extends through the rear panel of the instrument, through an opening provided for that purpose. This portion of the board forms an edge connector and is designated P202 PROGRAM INPUT.

4.84 The circuitry, shown simplified in figure 4.17, consists of the program logic, data gate, and the command/timeout circuitry. The program logic converts the control line data generated at P202 to correspond to the instrument control lines. The data gate passes or rejects the converted data; the gate is enabled when the program switch is operated and system control is selected on P202. A series of inputs with their outputs are shown in table 4.7. The timeout circuitry generates the necessary timeouts for delayed remote programming. The timeout periods are covered under paragraph 2.99.

Table 4.7 - Program Logic Conversion

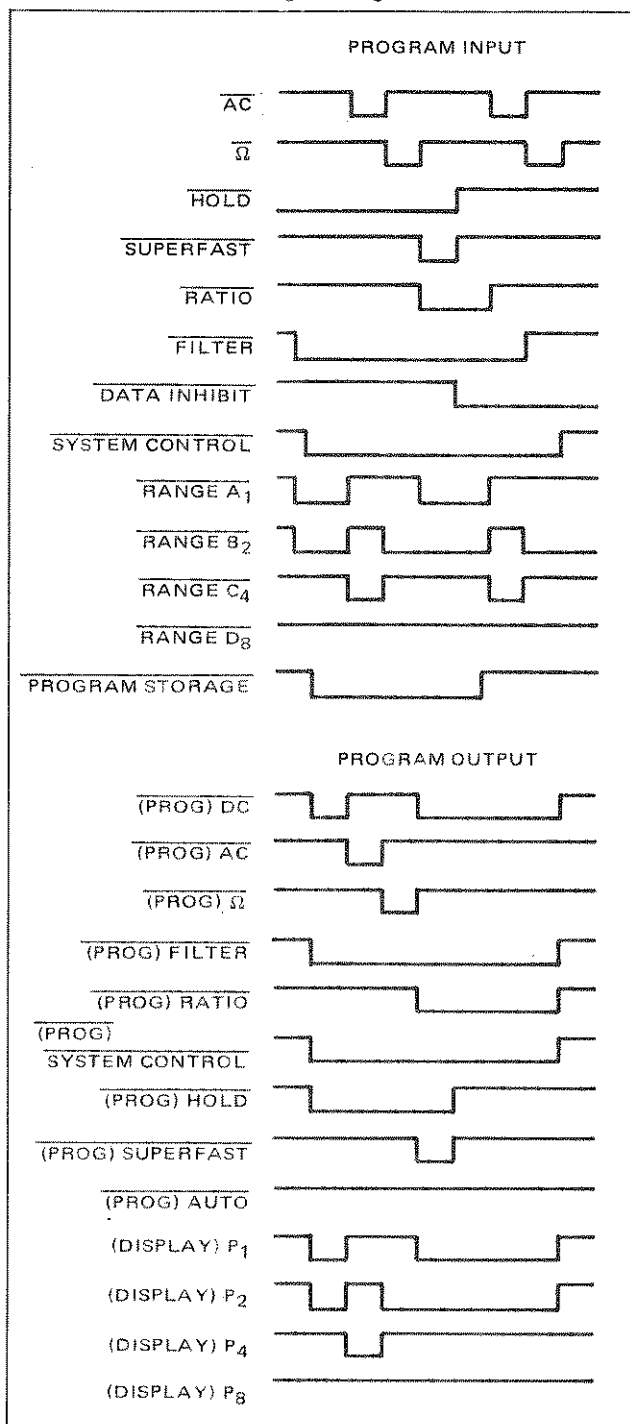

Table 5.1 - Required Calibration Equipment

Function	Qty	Item	Minimum Use Specifications	Suggested Equipment
DC	(1)	Saturated Standard Cell Bank (6 cells)	1 ppm, certified	EPPLEY 106
	(2)	DC Voltage Sources	0.1 ppm resolution	FLUKE 332B
	(1)	Voltage Divider Adjustable	0.1 ppm linearity	FLUKE 720A
	(1)	10:1 Voltage Divider, Fixed	1 ppm, Output Z \leq 10 Kohms	Fabricated*
	(1)	100:1 Voltage Divider, Fixed	1 ppm, Output Z \leq 10 Kohms	Fabricated*
	(2)	Null Detector/ μ Voltmeters	1 μ V sensitivity	FLUKE 845AR
AC	(1)	Thermal Transfer Standard	35 ppm @ 400 Hz, 50 ppm @ 40 kHz	HOLT 6A
	(1)	Thermal Voltage Converter	50 ppm @ 100 kHz	HOLT 11
	(1)	AC Voltage Source	1 ppm resolution	HP745A/746A
	(1)	Pulse Generator*	10 volts variable, 50 Ω output	TEKTRONIX 2101
Ω	(8)	Resistance Standards		
		10 Ω	10 ppm	ESI SR1 with corrections
		100 Ω	10 ppm	ESI SR1 with corrections
		1 K Ω	10 ppm	ESI SR1 with corrections
		10 K Ω	10 ppm	ESI SR1 with corrections
		100 K Ω	10 ppm	ESI SR1 with corrections
		1 M Ω	10 ppm	Fabricated*
		10 M Ω	50 ppm	ESI SR1 with corrections
100 M Ω	80 ppm	Fabricated*		
OTHER	(1)	Momentary Switch, SPST	—	—
	(1)	Phillips head screwdriver #1	—	—
	(1)	Insulated Adjustment tool	—	JFD5284
	(1)	10 Kohm 1/4 Watt 5% Carbon Resistor	5%	—
	(1)	1 Megohm 1/4 Watt 5% Carbon Resistor	5%	—

*See Text

5.1 SCOPE.

5.2 This section describes the calibration of the Dana Model 5900 DMM and the following options:

Model 52 Ohms/DC Converter

Model 32 AC/DC Converter, RMS

Model 33 AC/DC Converter, Averaging

Model 62 4-Wire Ratio

5.3 GENERAL.

5.4 The Dana Model 5900 undergoes rigorous testing and is precisely calibrated under closely controlled conditions, prior to leaving the plant. The procedure provided in this section is designed to recalibrate the Model 5900 and to keep the instrument operating within specifications for indefinite periods of time. If the instrument is equipped with the rear panel selectable input option, set the FRONT/REAR switch to the appropriate position for each of the checks in this section calling for the application of input signals to the instrument.

5.5 Required Equipment.

5.6 A list of the equipment required for calibration is provided in table 5.1. The specific types of equipment in the Suggested Equipment column are acceptable for calibration and provided as a guide in selecting suitable equipment; instruments having operating characteristics equal to or better than those indicated may be substituted.

5.7 Fabricated Calibration Equipment.

5.8 Two fixed voltage dividers, 10:1 and 100:1, are required for dc range calibration. The dividers provide the required accuracy and low output impedance not normally available on commercial equipment. The specifications of the dividers are indicated in table 5.1.

5.9 Two standard resistors are called out for ohms calibration, for which no commercially available standard resistors having the required accuracy are presently available. These can be fabricated by mounting precision resistors in a standard minibox on 5-wire binding posts.

Table 5.2 - Fixed Voltage Dividers

Ratio	Range Used on	Output Impedance	Accuracy
10:1	1V	≤10 KΩ	The absolute accuracy of each divider must be known to 1 ppm with the operating voltage applied (i.e., the voltage coefficient must also be known)
	100V		
100:1	0.1V		
	1000V		

Suitable types of resistors for the two ranges are listed below.

1 Megohm 2 ppm TC wirewound of known value

100 Megohm 25 ppm TC metal film of known value

5.10 DC Voltage Sources.

5.11 To produce voltage levels of necessary accuracy, special techniques are required. Suitable methods of generating these voltages are shown in figures 5.1 and 5.2.

5.12 10 VOLT SOURCE

5.13 A precise and traceable source of 10 volts is required, not only for calibrating the 10 volt range, but also as a reference for generating highly accurate .1, 1, 100, and 1000 volt levels. The 10 volt source used must satisfy the following requirements.

- It must be traceable to the National Bureau of Standards;
- It must have a total accuracy of 1.1 ppm;
- It must have a low output impedance.

A source filling these requirements is shown in figure 5.1. This circuit consists of a null detector, 7-decade voltage divider, a dc voltage supply, and a bank of saturated standard cells. Two advantages of this particular hookup are that; (a) there is minimal loading of the standard cells and (b) stability, not accuracy, is the primary requirement of the dc voltage supply.

5.14 The output of this circuit is set to a precise 10 volts by setting the voltage divider to the value of the standard cells. The dc voltage source is then adjusted to produce a null on the null detector. The accuracy of the 10 volt source is within 1.1 ppm.

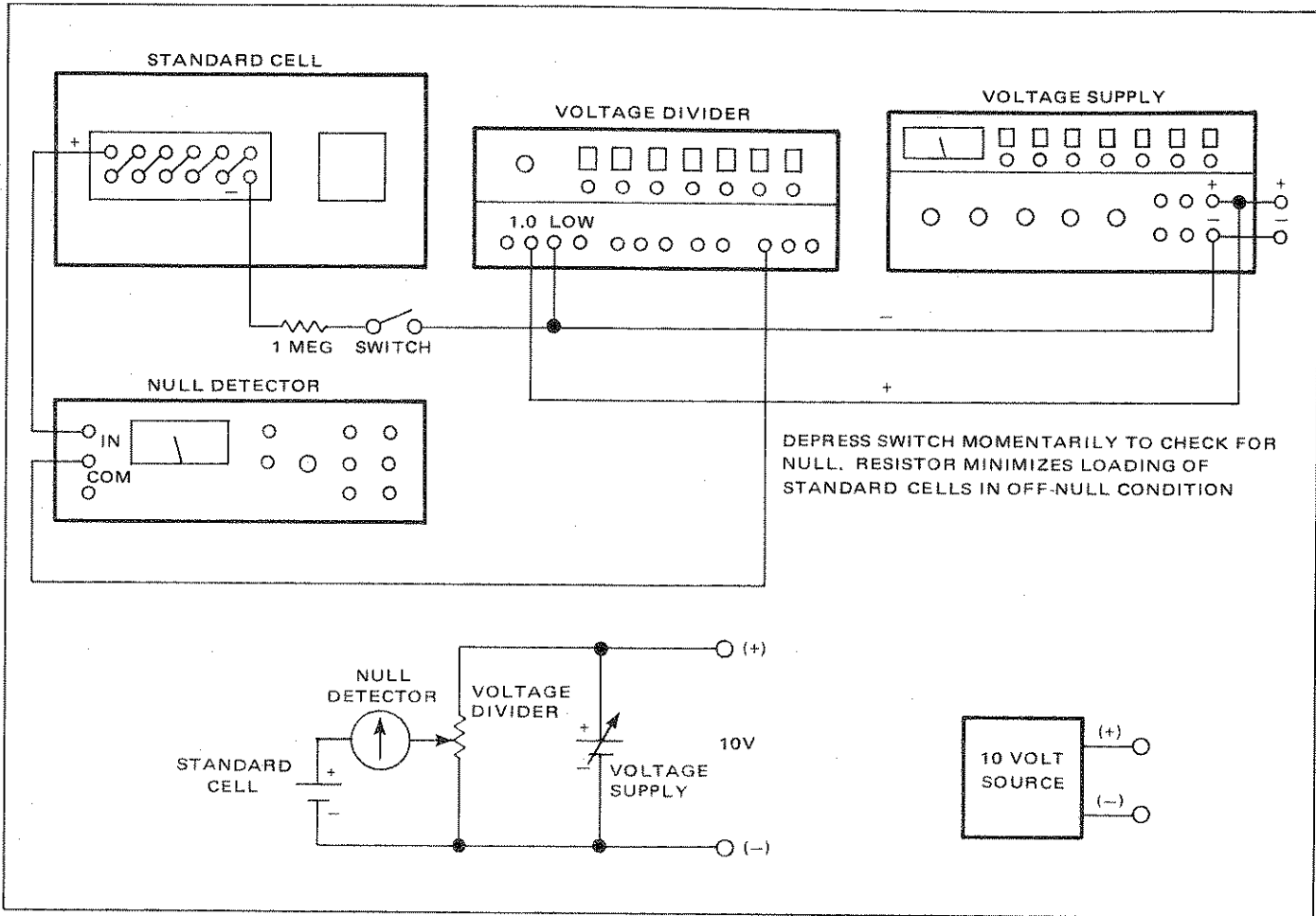

Figure 5.1 - 10 Volt Source

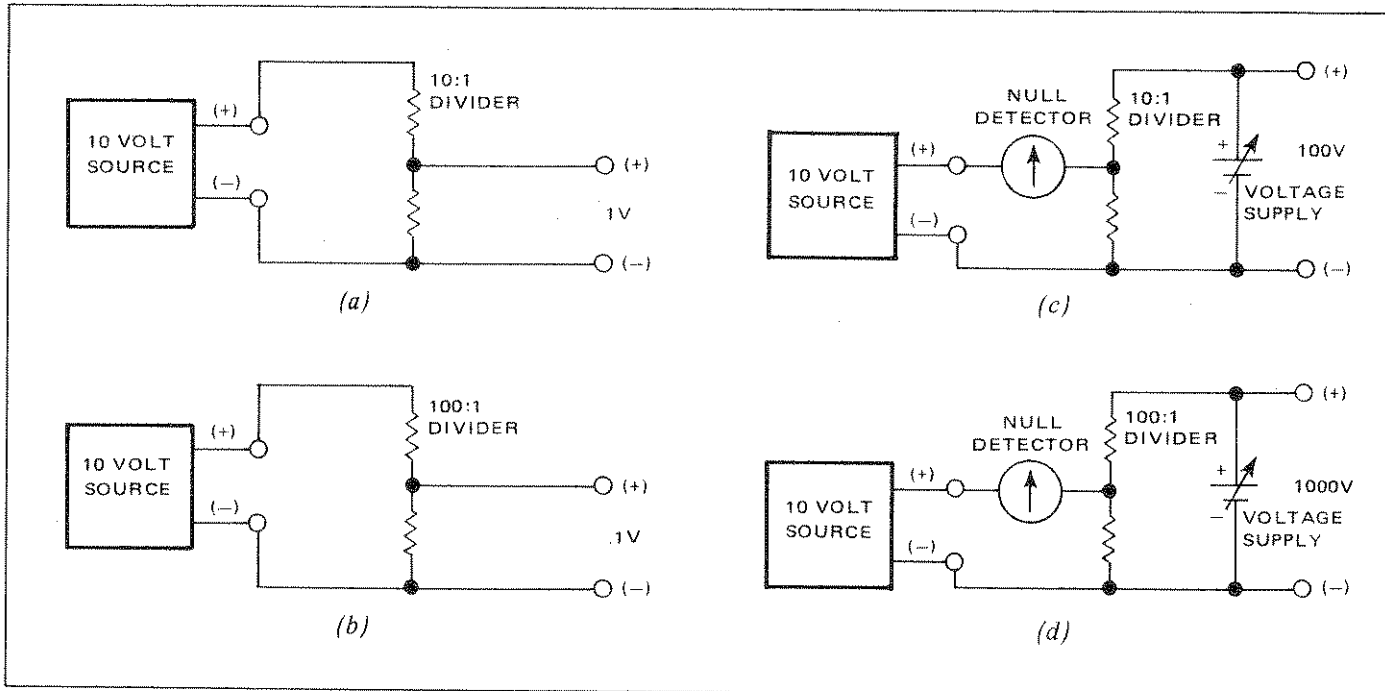

Figure 5.2 - Generating Accurate DC Levels

Table 5.3 - DC Source Accuracies

Range	10 Volt Source	Fixed Divider	Total Accuracy	24 hr. DMM Accuracy	Times Better
10	1.1 ppm	--	1.1 ppm	10 ppm	9
1	1.1 ppm	1 ppm	2.1 ppm	10 ppm	4.8
.1	1.1 ppm	1 ppm	2.1 ppm	20 ppm	4.8
100	1.1 ppm	1 ppm	2.12 ppm	10 ppm	4.7
1000	1.1 ppm	1 ppm	2.12 ppm	10 ppm	4.7

5.15 OTHER SOURCES.

5.16 The remainder of the dc sources can be generated by the circuits shown in figure 5.2. Each of these hookups use a calibrated 10 volt source having the characteristics of the one previously described.

5.17 ACCURACY, DC.

5.18 The accuracy of the dc voltage sources is obtained by adding the various sources of error in each hookup;

errors in this discussion are defined in parts per million (ppm). For the 10 volt source, the error is the sum of the standard cell bank (certified at 1 ppm) and the voltage divider (0.1 ppm), giving a constant 1.1 ppm. In table 5.3 is shown the errors of each voltage source, the total accuracy of each hookup, the accuracy of the Model 5900 DMM, and the degree to which the sources exceed the required accuracy of the DMM (4 to 10 times better is the suggested accuracy ratio per MIL-M-38793).

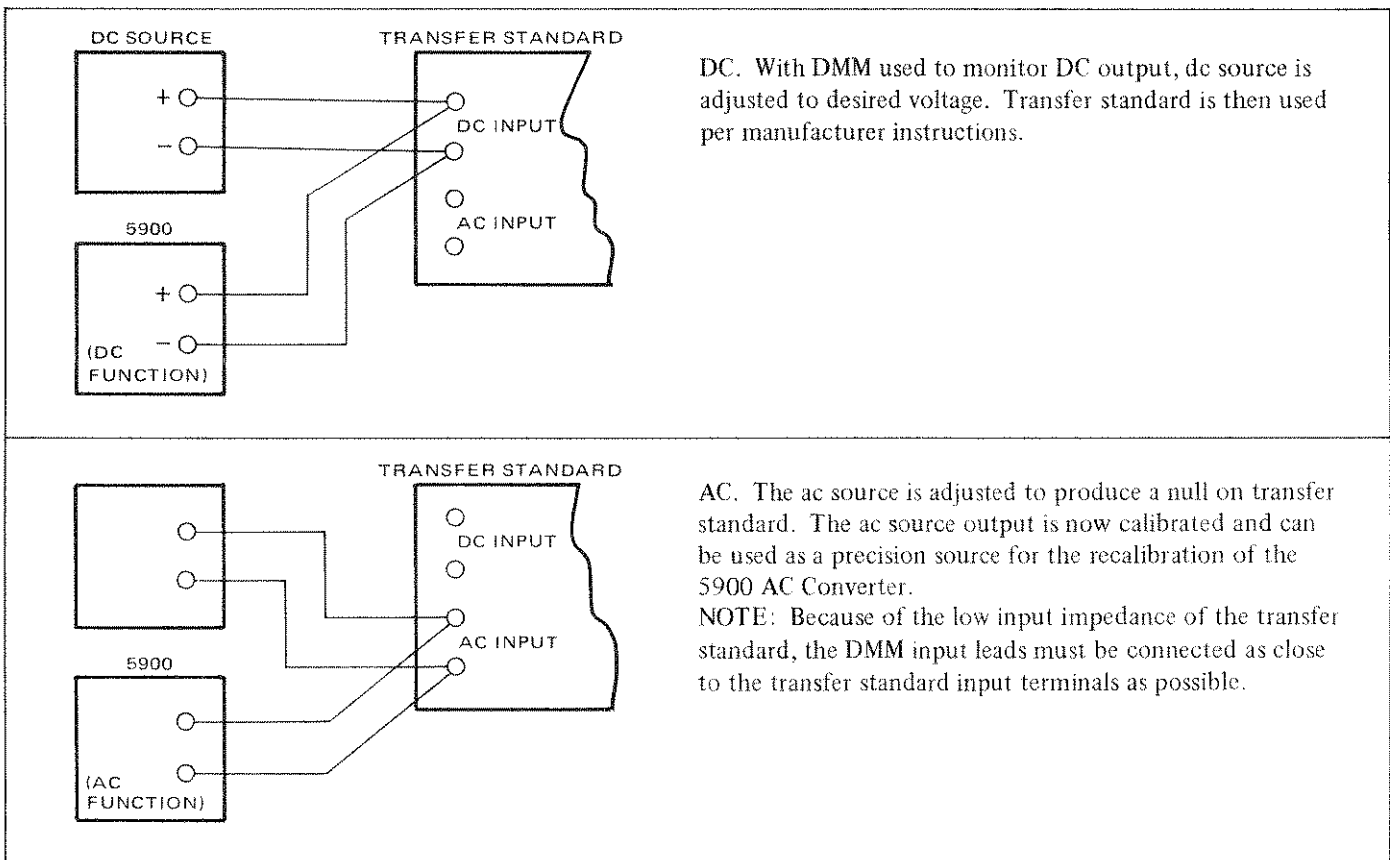

Figure 5.3 - AC Source

Table 5.4 - AC Source Accuracies

INPUT		ACCURACY				
AC Source		Thermal Transfer Standard	DC Source	Total AC Source	Model 33 (Spec)	Model 32 (Spec)
Volts	Freq					
1, 10, and 100 Volts	400 Hz	35 ppm	10 ppm	45 ppm	200 ppm	
	500 Hz					600 ppm
	50 kHz	50 ppm		60 ppm		1800 ppm
	100 kHz				400 ppm	
500 Volts	40 kHz	50 ppm		60 ppm	400 ppm	900 ppm
1000 Volts	400 Hz	52 ppm		62 ppm	200 ppm	
						600 ppm

5.19 AC Voltage Sources.

5.20 The generation of accurate ac signals for calibrating the ac converter ranges, requires the use of a thermal transfer standard and a precise dc standard as well as a stable ac source. Sufficient accuracy can be obtained by using a dc source and the Model 5900 being calibrated (immediately after the dc calibration has been completed). The circuitry connections are shown in figure 5.3. Information on the use of the transfer standard can be obtained from the operators manual accompanying the standard. The 5900 is used to set the dc source to the desired voltage; the thermal transfer standard is then used to calibrate the output of the ac source. The calibrated ac source is used to calibrate the 5900 ac converter. This procedure is repeated for each range.

5.21 ACCURACY, AC.

5.22 The accuracy of the ac source is equal to the sum of the transfer standard accuracy and the accuracy of the dc source. The accuracy of the setup for each range and frequency used in the calibration procedures as well as the specified accuracy of the converters is provided in table 5.4.

5.23 PRELIMINARY PROCEDURE.

5.24 Warmup.

5.25 Apply power to the instrument and allow two (2) hours of warmup time before calibrating with instrument covers in place.

5.26 Familiarization.

5.27 Prior to starting the procedure, read all of the steps and verify that all of the necessary equipment, tools, and

miscellaneous hookup cables required for the calibration procedure are readily available. Verify that all of the equipment used in the calibration is warmed up for the period prescribed by the manufacturer to reach full accuracy.

5.28 Calibration Points.

5.29 The location of the calibration points (except ac) used in the calibration procedure are shown in figure 5.4. The ac calibration points are shown in figure 5.8. Access to the calibration points is gained by removal of the top cover; the cover is secured to the DMM by captive screws located in each of the four corners of the cover. Directly beneath the cover is located a metal shield with access holes to calibration points (except ac). The shield is part of the instrument internal guard system and helps to reduce noise. For reference, an abbreviated form of the basic calibration procedure is silkscreened to the top of the shield. The shield is to be left in place unless specific instructions are given for removal.

5.30 Environmental Considerations.

5.31 The ambient temperature of the calibration environment shall be held to $23^{\circ}\text{C} \pm 1^{\circ}\text{C}$.

NOTE

In instruments equipped with the optional 4-wire ratio option it is necessary to remove the 4-wire ratio circuit board and connect jumpers W2 and W3 on the interconnection board. The shield is removed for access to the circuit board and then replaced prior to calibration of the instrument.

5.32 RECALIBRATION PROCEDURE.

5.33 The procedure is designed to produce the highest accuracy in the least number of steps while minimizing interaction between adjustments. To ensure accuracy, do

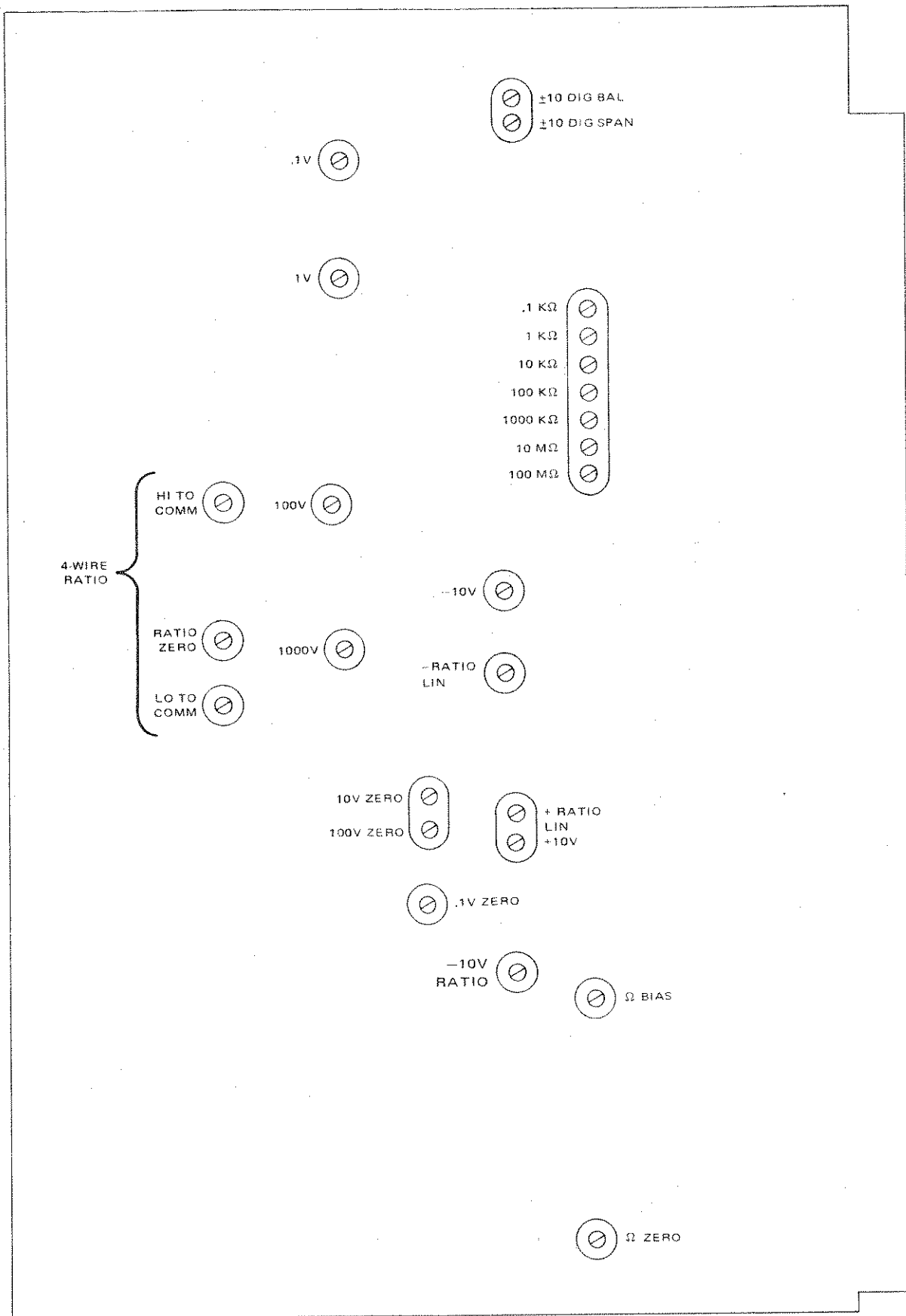

Figure 5.4 - Adjustment Locations

not deviate from the order of adjustments as given in the procedure.

WARNING

Removal of covers exposes potentially lethal voltages. Avoid contact with internal electrical connections while unit is connected to AC Power source.

5.34 Isolator Zero.

- Select DC function and .1 volt range. Short the \pm input terminals; connect microvoltmeter to ANALOG OUTPUT terminals. Set DC OFFSET (front panel) to the center of its mechanical span.
- Adjust R14 (.1V Zero) on Isolator for a microvoltmeter reading of less than 100 microvolts.
- Replace the jumper across the \pm INPUT terminals with a 1 Megohm resistor. Adjust R3 (100V ZERO) for a reading of less than 1 millivolt.
- Replace the resistor with a jumper. Select 10V range. Adjust R7 (10V Zero) for a reading on the microvoltmeter of less than 20 microvolts.
- Repeat the above steps until all ranges are zeroed within the indicated tolerance.

5.35 DC Voltage Zero and Gain.

- Select DC function and 10V range. Apply an input of +00.0010V. Observe readout and reverse polarity of input (-00.0010V). Adjust R27 (± 10 DIGIT BAL) for same readout for "+" or "-" inputs. Adjust R40 (± 10 DIGIT SPAN) for ± 10 digits.
- Apply inputs listed in following tables to the front panel input terminals and the rear panel ratio input terminals. Select mode as listed for each step and adjust indicated control for a readout of ± 10.0000 .

F/P Input	Ratio Input	Select Mode	Adjust (on Digitizer)
-1.00000V	+1.00000V	Ratio	R5 (-RATIO LIN)
+1.00000V	+1.00000V	Ratio	R64 (+RATIO LIN)
-10.0000V	+10.0000V	Ratio	R2 (-10V RATIO)
-10.0000V		DC	R4 (-10V)
+10.0000V		DC	R57 (+10V)

- Repeat the above steps as required until all steps are calibrated.
- Verify that the voltage at the ANALOG OUTPUT terminals (on rear panel) is the same as the voltage on the input terminals at various input levels ($\pm 10V$, $\pm 1V$, etc.).

5.36 DC RANGE CALIBRATION.

5.37 Apply inputs listed in the following table. Select DC function and range as listed for each step. Adjust the indicated control for a readout equal to the input voltage.

Input	Range	Adjust
+1.00000V	.1	R18 (.1V)
-1.00000V	.1	R18 (.1V)
+1.00000V	1	R5 (1V)
-1.00000V	1	R5 (1V)
+100.000	100	R11 (100V)
-100.000	100	Verify
+1000.00	1000	R13 (1000V)
-1000.00	1000	Verify

5.38 OHMS CALIBRATION (Figure 5.4).

5.39 Ohms Zero.

- Select Ω -M Ω function and the 10 Megohm range. Short the \pm INPUT and \pm CURRENT terminals together. Adjust R56 (Ω ZERO) for zero readout.
- Remove short from INPUT and CURRENT terminals. Connect a 10 Megohm standard resistor across the \pm INPUT terminals. Do not connect the + CURRENT lead (figure 5.5).

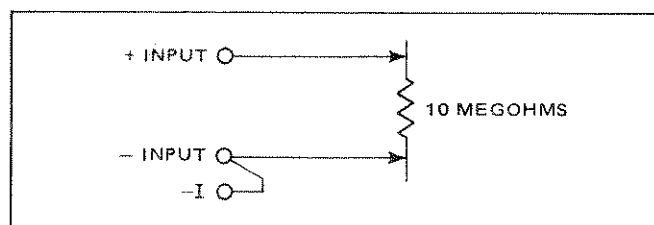

Figure 5.5 - Ohms Input Connection

c. Adjust R9 (Ω BIAS) for a readout of zero

5.40 OHMS RANGE.

a. Connect standard resistors to the input in the order listed in the following table. Select range as listed for each step and adjust the indicated control for a readout equal to the standard resistor value. Connect as shown in figure 5.6.

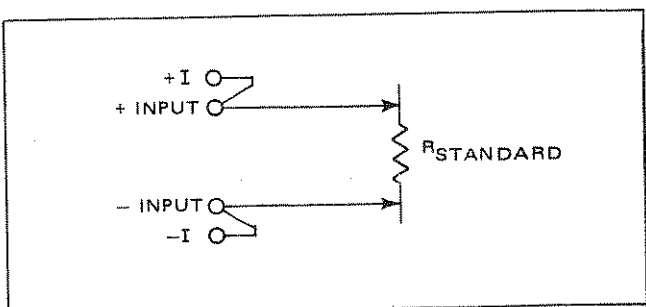

Figure 5.6 - Connections for Ohms Range Adjustment

Standard Resistor	Range	Adjust
100M	100M	R51 (100M)
10M	10M	R47 (10M)
1M	1000K	R45 (1000K)
100K	100K	R43 (100K)
10K	10K	R5 (10K)

b. Connect input with 4-wire configuration (figure 5.7) and complete the adjustments of the low ranges.

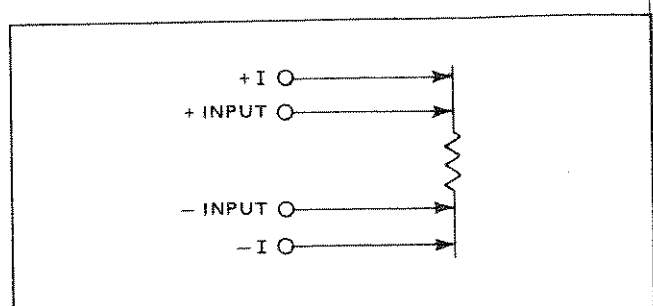

Figure 5.7 - 4-Wire Connections

Standard Resistor	Range	Adjust
1K	1K	R22 (1K)
100	.1K	R36 (.1K)
10	10	No adjustment; verify accuracy

5.41 AC CALIBRATION (Model 33).

5.42 AC Converter Zero (Figure 5.8).

- a. Remove Scaling Amp, insert Scaling Amp Bypass card (Dana P/N 410617) in its place, and install AC Converter on extender. Select AC function, any range, and leave input open.
- b. Connect the microvoltmeter with a 10 kilohm resistor in series with the positive lead to TP3, with negative side to TP6 (common). Adjust R35 for a microvoltmeter reading of less than 10 μ volts.
- c. Connect the + microvoltmeter lead alternately between TP5 and TP1. Adjust R5 so that the voltages at TP5 and TP1 are equal (balanced) within approximately ± 10 μ volts (opposite polarities). The voltage at each of the two test points must be less than ± 20 μ volts.

5.43 Frequency Response.

- a. Depress FILTER switch. Apply 1 volt at 400 Hz and record readout. Apply 1 volt at 100 kHz and adjust C13 for same readout (± 10 digits) as obtained with 400 Hz.
- b. Remove extender from AC Converter; remove Scaling Amp Bypass card. Install AC Converter and Scaling Amp into instrument.
- c. Apply the inputs listed in the following table and adjust the indicated control on Scaling Amp for a readout equal to the input.

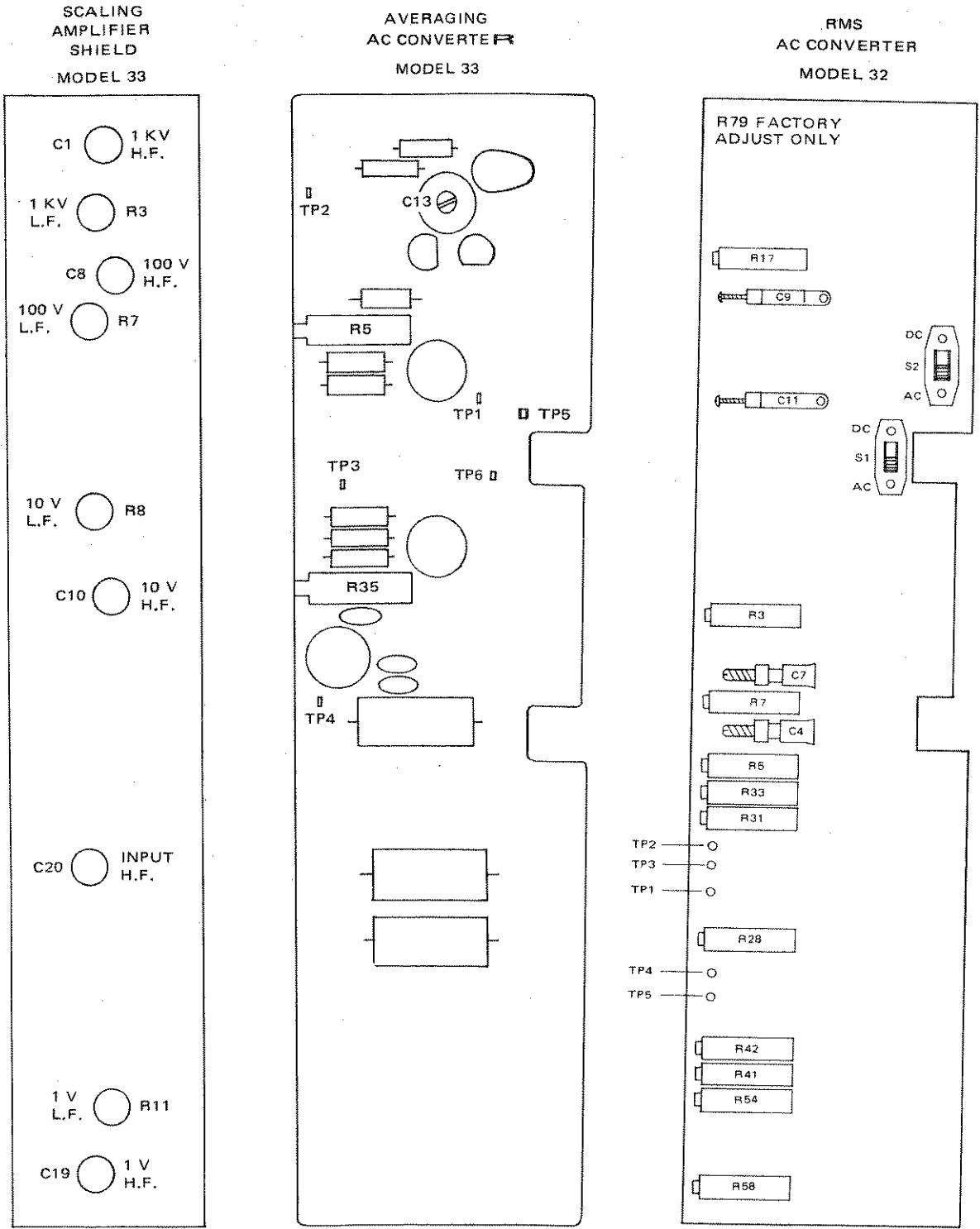

Figure 5.8 - AC Adjustment Locations

E_{in}	Freq.	Adjust
.01000	400 Hz	AC OFFSET (front panel)
1.00000	400 Hz	R11 (1V L.F.)
10.0000	400 Hz	R8 (10V L.F.)
100.000	400 Hz	R7 (100V L.F.)
1000.00	400 Hz	R3 (1000V L.F.)
—	—	C1 (1000V H.F.) set to center of span
500.00	40 kHz	C20 (INPUT H.F.)
1.00000	100 kHz	C19 (1V H.F.)
10.0000	100 kHz	C10 (10V H.F.)
100.000	100 kHz	C8 (100V H.F.)

5.44 RMS AC CALIBRATION (Model 32).

NOTE

Use 10 K Ω resistor in series with + lead of microvoltmeter.

- Set DVM power switch to off. Extract converter. Set S1 and S2 to DC (away from center of board), replace converter and set power switch to on. Select AC and 1 volt range on DVM front panel. Allow 10 minutes for temperature to stabilize.
- Connect jumper across DVM input terminals. Connect the microvoltmeter to TP1 (+) and TP5 (-). Adjust R17 for a microvoltmeter reading of $0 \pm 30 \mu\text{V}$. Remove + microvoltmeter lead from TP1. Turn R41 fully clockwise.
- Connect microvoltmeter + lead to TP4. Adjust R42 for a microvoltmeter reading of $+20 \mu\text{V} \pm 10 \mu\text{V}$.
- Connect + microvoltmeter lead to TP2. Adjust R33 for a microvoltmeter reading of $0 \pm 30 \mu\text{V}$. Remove microvoltmeter + lead from TP2.

- Connect + microvoltmeter lead to TP3. Adjust R31 for $0 \pm 30 \text{ mV}$. Remove + microvoltmeter lead from TP3.
- Connect + microvoltmeter lead to TP4. Adjust R41 counterclockwise until the voltage at TP4 reads $0 \pm 5 \mu\text{V}$. Remove microvoltmeter leads and remove jumper across DVM input.
- Apply -1.00000V DC and note DVM display.
- Reverse polarity of input to $+1.00000\text{V}$ DC and adjust R28 to obtain approximately the same DVM display as obtained in step g. Repeat steps g and h until the two readings are within .01% of each other. Remove DC supply from DVM input.
- Apply $+0.10000$ to DVM input and note DVM display.
- Reverse polarity of input to -0.10000 and verify DVM display is within ± 5 digits of the reading obtained in step i. If not, use R31 to balance the readings.

NOTE

R54 is an FSV adjustment and is reset only if major repairs have been performed on the converter. In this event, perform the following adjustment:

Apply a calibrated 1.00000V RMS pulse train with a crest factor of 7 and a period of 1 millisecond (1 kHz repetition rate). Adjust R54 for a readout of 1.00000. Remove the pulse generator from the DVM input and continue with the calibration procedure starting at step k.

- Set power switch on DVM to off, extract converter, set S1 and S2 to AC (toward center of board). Replace converter in DVM. Reapply power and allow 10 minutes for temperature to stabilize. Select FILTER.
- Connect the AC source to the DVM input terminals. Apply the inputs listed in the following table and adjust the indicated control for the proper readout.

Range	INPUT		Adjust	Readout
	AC Voltage	Freq		
1V	1.0000	500 Hz	R58	1.00000
1V	.1000	500 Hz	a.c.offset	0.10000
Repeat steps for R58 and a.c. offset until no adjustment is required.				
1000V	1000.0	500 Hz	R3	1000.00
1000V	500.00	40 kHz	C11*	500.000
1V	1.0000	50 kHz	C9*	1.00000
10V	10.000	500 Hz	R7	10.0000
10V	10.000	50 kHz	C7*	10.0000
100V	100.00	500 Hz	R5	100.000
100V	100.00	50 kHz	C4*	100.000
*Use an insulated screwdriver when adjusting the capacitors. High voltage present on C11.				

5.45 4-WIRE RATIO CALIBRATION.

NOTE

DC calibration of the instrument must be completed before calibrating 4-wire ratio. The DC calibration must be performed with the 4-Wire Ratio board removed and jumpers installed across W2 and W3 on the interconnection board.

- Install 4-Wire Ratio board; remove jumpers across W2 and W3. Select RATIO, 10V RANGE, and DC function.
- Connect $-1.0V$ to front panel INPUT terminals; connect $+1.0V$ to REF INPUT terminals on rear panel. Connect a jumper from high side of reference input to ANALOG COMMON (on rear panel).
- Adjust R12 on 4-Wire Ratio board for a readout of -10.0000 (figure 5.9).
- Increase voltage at INPUT terminals to -10.0 volts; increase REF INPUT to $+10.0$ volts. Adjust R10 for a readout of -10.0000 .
- Repeat steps b through c until both are achieved without further adjustment.

- Remove jumper from high side of reference input to common. Connect the jumper between low reference input and common. Adjust R9 for a readout of -10.0000 . Remove jumper and verify that the readout does not change by more than one digit.
- Apply $+1.0V$ to both signal and reference inputs. Verify a readout of $+10.0000$.

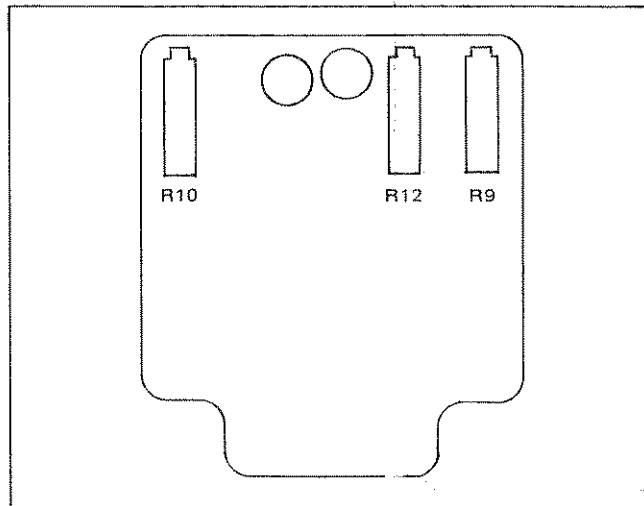

Figure 5.9 - 4-Wire Ratio Adjustment Locations

5.46 TROUBLESHOOTING

5.47 This procedure is provided to aid in locating the cause of an instrument malfunction. The procedure consists of a systematic basic instrument operation check, a table of symptoms and probable causes, and a brief description of major areas of the instrument circuitry from a troubleshooting standpoint. To eliminate as much as possible redundant material, frequent reference is made to information located in other sections of the manual.

5.48 Troubleshooting Equipment

5.49 The equipment listed in table 5.1 can be used for the procedure with the addition of an oscilloscope such as the Tektronix type 453. Access to the main circuitry is gained by removal of the top cover and shield.

5.50 Power Supply Check

WARNING

Removal of covers exposes potentially lethal voltages. Avoid contact with internal electrical connections while unit is connected to AC Power source.

5.51 Before proceeding with the analog and digital circuitry, check that all the supply voltages are present. If a discrepancy is found, proceed to table 5.5.

Table 5.5 - Power Supply Check

Low or Zero output of Supply:	
1.	Set power switch to OFF.
2.	Remove all plug in boards to eliminate possible source of shorts.
3.	Apply power and recheck supply output.
a.	If normal, check plug in boards
b.	If low, check components on main board for excessive heat dissipation.
No output of any Supply:	
1.	Disconnect power cable from line voltage and back of instrument.
2.	With power switch on, check for continuity (Low DC resistance) between HI (pin 2) and LO (pin 1) of J203 (typically, 110 volt range is 12Ω , 220 volt range is 35Ω). An open indicates a failure of F201, S201, S202, or T1.

5.52 Operational Check

5.53 The check consists of narrowing down the problem to a specific area or circuit. This is done by checking out the basic instrument functions in a prescribed sequence and referring to the troubleshooting guide when the instrument fails to perform as indicated.

5.54 Preliminary Instrument Setup

- a. Select DC function, 1 Range, Filter OUT, Ratio Out, Data Output Out, Remote Control Out, and Rate Control fully clockwise.
- b. Verify the line voltage selector on the DMM rear panel is positioned for the available line voltage and connect power cable.
- c. Perform the checks indicated in Table 5.6 if the instrument fails to provide the indicated output, refer to table 5.7 for assistance.

5.55 Circuit Descriptions

5.56 The remaining paragraphs describe the operation of the instrument circuitry from the standpoint of specific operating characteristics. These are to be used in troubleshooting to verify proper operation. The majority of the circuitry operates in a linear flow; that is, a signal is generated at one point and processed, encoded, decoded, or converted through various other circuits. If the output of one of the circuits is incorrect, the circuit is bad.

Table 5.6 - Operational Check

Step	Input	Annunciator	Display *
1.	a. Connect jumper across + and - input b. Set power switch on	+ or -	0.00000
2.	a. Remove jumper from input b. Apply +1 volt to input (DC source)	+	1.00000
3.	Reverse Polarity of input source	-	1.00000
4.	Select 100 mV range on DMM	NO	.160000
5.	Reduce input to -0.1 volt (DC source)	-	100.000
6.	Select 10 volt range on DMM	-	00.1000
7.	Select 100 volt range on DMM	-	000.100
8.	Select 1000 volt range on DMM	-	0000.10
9.	Increase input voltage to -200 volts	-	0200.00
10.	Reduce DC Source and remove source from input		
*May require adjustment of front panel offset			

5.57 MEASUREMENT LOGIC. These circuits are covered in paragraphs 5.58 through 5.63 and include the control and display logic. Symptoms of a failure in this area is the Display does not change with a change of input signal (see block diagram in figure 4.16 and schematic - figure 6.3)

5.58 CLOCK OSCILLATOR. The clock oscillator runs continuously at 6 MHz. If there is no signal, repair the clock. (5 MHz for 50 Hz operation). Q1, U38C, Y1, U13A

5.59 DECADE COUNTERS. These IC's (U14-U18, U33A) are the decade counters and are driven by the 6 MHz clock and run only during measurement cycle. If they do not run, replace them.

5.60 LATCHES. These IC's (U7-U11, U38B) store the information appearing at the input line (2, 6, 7, 3) upon receipt of a transfer pulse (PGMD) the stored data

Table 5.7 - Troubleshooting Guide

Symptom	Diagnosis	Probable Cause	Reference
Display Blank		Power Supply	Para. 5.50
Left 3 digits blank		Leading Zero Blanking	Para. 5.61
Decimal point wrong position	Range Logic	Annunciator Logic	Para. 5.66
Display does not change with a change in input signal	Instrument locked up	Clock	Para. 5.58
		Decade Counters	Para. 5.59
		Measurement Logic	Para. 5.57
		Control Logic	Para. 5.63
		Digitizer Logic	Para. 5.64
		Isolator	Para. 5.65
Display numbers incorrectly formed	BCD to 7-Line Converters		Para. 5.61
Manual range selection incorrect	Range Logic	Manual Range Encoding	Para 4.56 - 4.59
Readout does not Zero properly	Offset Error	DC Offset Adjust	R 60
		Isolator	Para. 5.65
		Digitizer Logic	Para. 5.64
Reading Unstable	Isolator	Oscillation	Para. 5.65
		Attenuator Relays	Table 5.9 Table 5.10
Improper Reading	Out of Calibration		Para. 5.1-5.45
	Non Linear	Isolator	Para. 5.65
		Integrating Capacitor	C8
	Will not read full scale	Digitizer Logic	Table 5.8
Isolator		Table 5.9	

appears and remains at output lines (16, 10, 9, 15) until the next transfer pulse. (PGMD).

5.61 BCD TO 7-LINE CONVERTERS. These units U1 through U6 convert the data from the counters to 7-line for the display and provide the leading zero blanking function. These units may be checked by swapping if a malfunction is suspected.

5.62 READ-OUT. The LED's on the readout board (LED 1 through LED 6) are controlled by the BCD to 7-line converters and are powered by the driver decades strobing circuit (U44, Q19). Failure of strobe circuit is indicated by blank display or excessive current drain from +5V regulated supply.

5.63 CONTROL LOGIC. This circuit controls the operation of the instrument and consists of the program logic (U38B, U38D, U13D, U32A, U38A, U36A-E), program

counter (U37), read rate generator (Q43, Q42, Q9, Q10, U31B, U30A), program clock (U39), clear logic (U28A, B, U29B), counter clear logic (U19A, U13F, U27B, U27A, U34C, U20A, C, D, U13E, U34D), decimal logic (U41), auto range logic (U40A, D, U26A, U19B, D), are axis crossing/polarity logic (Q2, Q3, U32C, U30B, U26B, U29A). Failure of any of above circuits would be indicated by a locked-up display. See figure 4.13 for timing and waveform diagram.

5.64 DIGITIZER LOGIC AND 10V REFERENCE AMP-LIFIER. (See block diagram, figure 4.12 and schematic figure 6.13). This circuitry performs the A/D conversion. It is mounted on a single PC Board and mates with connector J9 on main logic board. The circuitry includes: integrator and switching network, gain stage, null detector, transformer driver, signal and reset logic, switch controls and ± 10 volt reference supplies (see paragraph 4.38 through 4.51 for theory of operation). For troubleshooting chart on digitizer and 100 reference amplifier see table 5.8.

Table 5.8 - Troubleshooting Chart – Digitizer and 10V Reference Amplifier

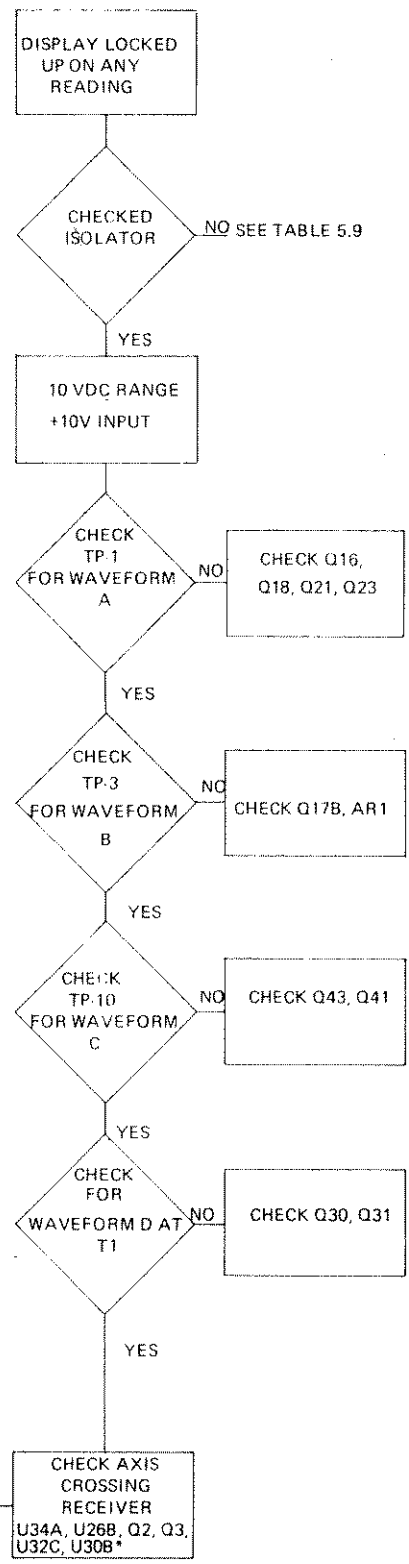
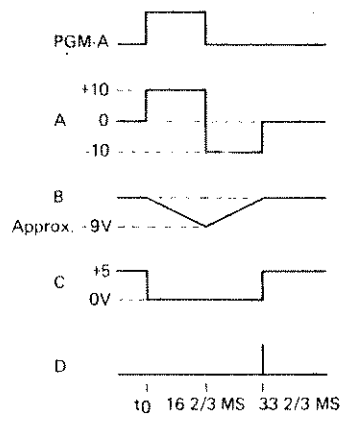
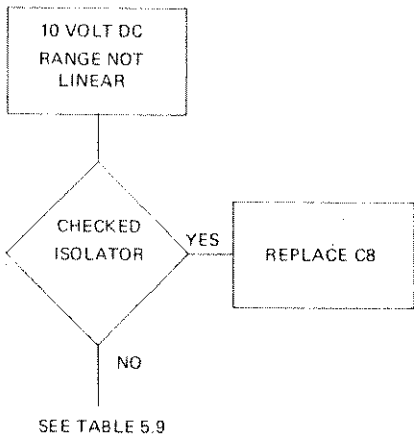
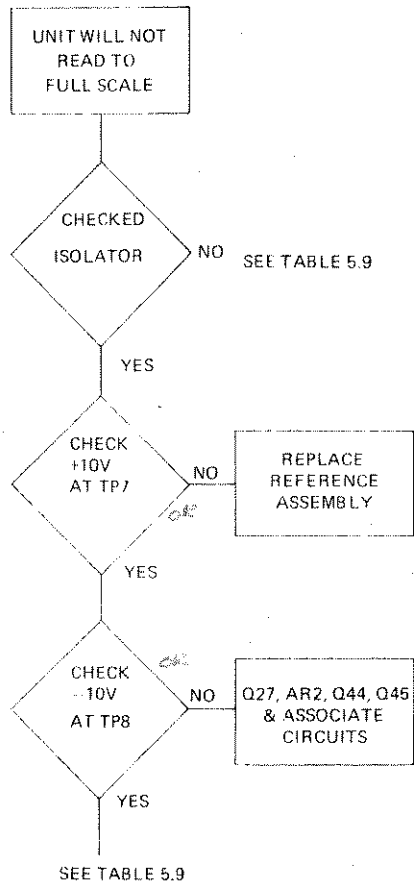

*ON LOGIC & INTERCONNECTION BOARD

**Table 5.9 - Troubleshooting Chart —
Isolator and Attenuator Boards**

Sympton	Probable Cause
1. Unstable, Noisy Reading on all functions	a. Oscillation of AR2, or AR4 b. Bad Q6 c. Filter circuit AR5 K1 (Isolator) d. Attenuator relays K1, K2, K3, K4
2. Won't Read Full Scale	a. Q8 or Q9 b. See table 5.8
3. Display locked on over-load	a. Q7 ✓ b. AR3 (Check AR4 pin 6 if 20 volts replace AR3) ✓ c. Q6 ✓ d. Q2, Q3, Q4, or Q5 e. See table 5.8
4. Excessive Input Bias Current	a. Adjust R3, R7 b. Q1 failure if cannot adjust

5.65 ISOLATOR. The isolator is a single printed circuit board and mates with connector J8 on the main logic board. The isolator operates in conjunction with the attenuator board as shown in figure 4.10. See table 5.9 for troubleshooting information.

5.66 ANNUNCIATOR LOGIC. This logic controls the selection of annunciator, autoranging and polarity as shown in tables 4.5 and 4.6, and schematic figure 6.17. Failure of these circuits would cause improper range coding, improper annunciation, improper decimal placement, or improper autoranging.

5.67 OPTIONAL ACCESSORIES. Options include AC converter, RMS AC converter, ohms converter, remote programming, and four-wire ratio. See troubleshooting guide table 5.10 for more information.

5.68 BOARD REVISION.

5.69 Every effort is made to keep the manual concurrent with the instrument despite changes to the design, which are an inevitable adjunct of the manufacturing process. The manual is updated and periodically reprinted throughout the year. In between printings, Addendums and Errata Sheets are added to the manual if required to implement the reprinted copy.

Table 5.10 - Troubleshooting Chart — Optional Accessories

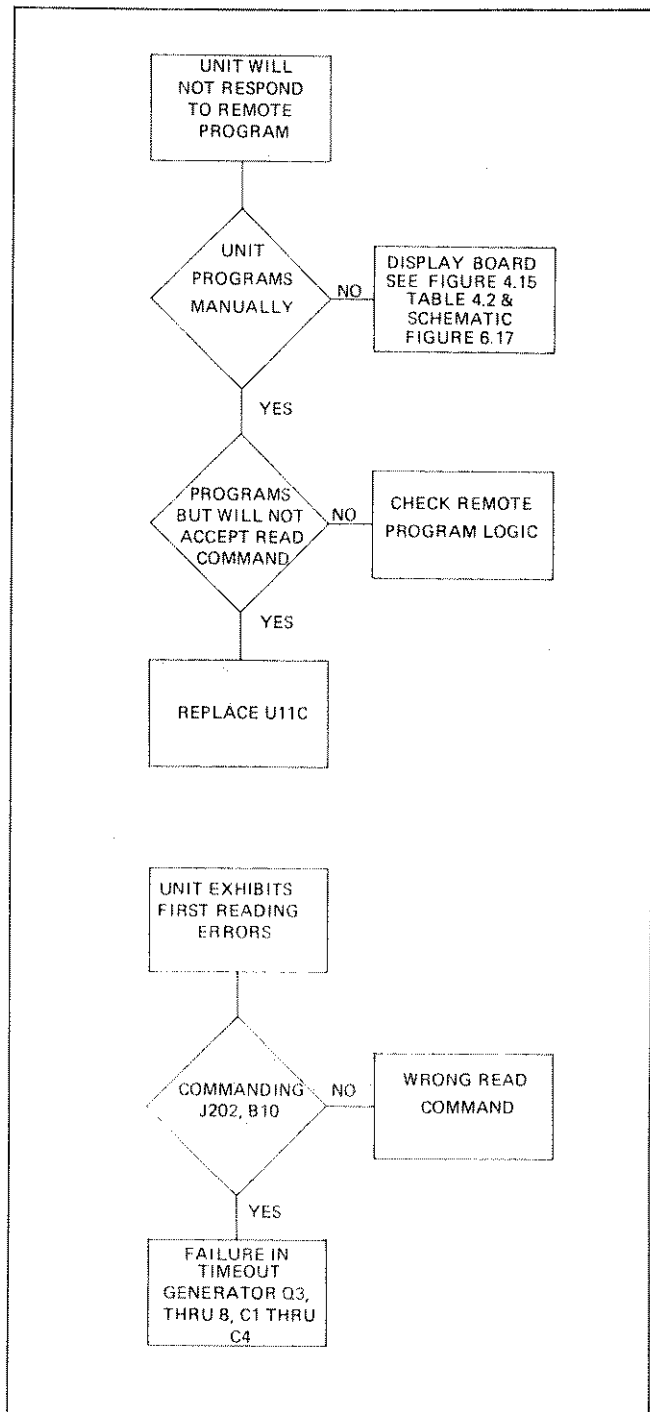

5.70 Any design change is accompanied by an updating of a board revision. Such change could be as simple as a revised hole size or as complex as major modifications of the circuitry. The revision of a board is indicated by the letter preceding the assembly number stamped on the board; the revision of the assembly drawing in Section 6 or on an Errata Sheet is indicated by the letter following the assembly number, located below the drawing. Comparing the revision letters can indicate how closely the drawing corresponds to the board.

Table 5.10 - Troubleshooting Chart—Optional Accessories (continued)

